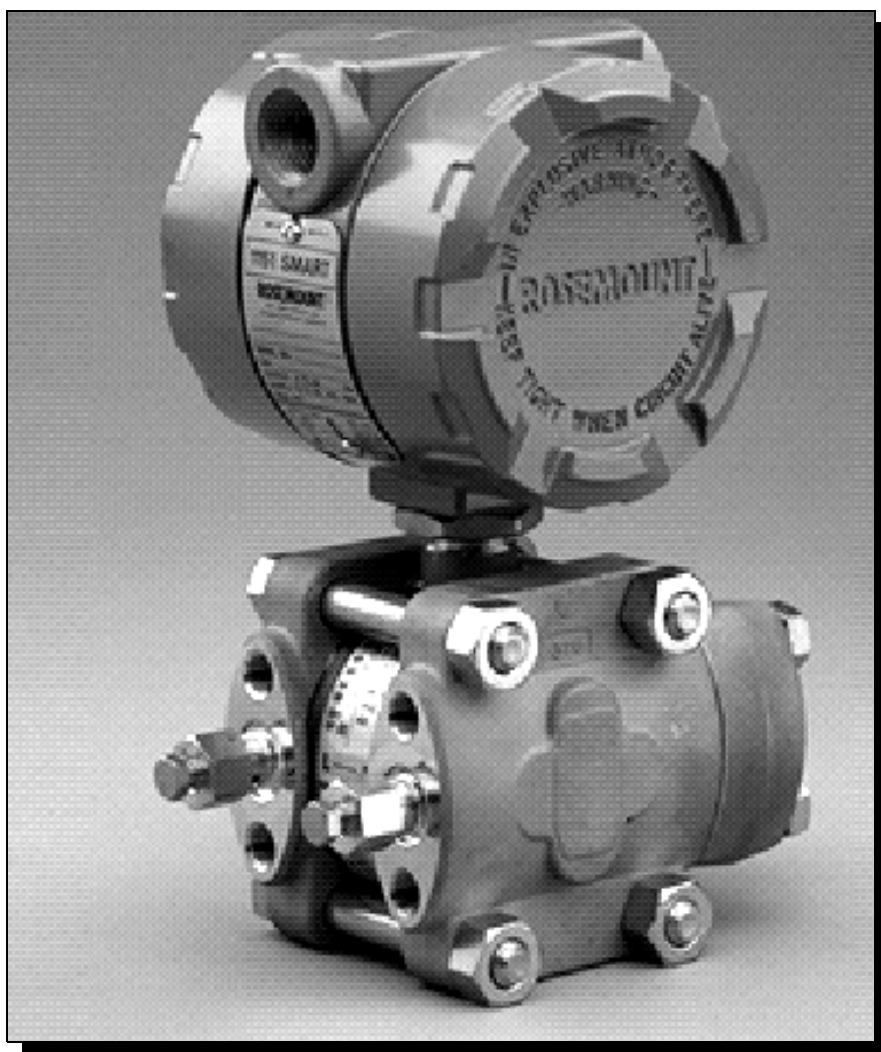


# Model 1151 Smart Pressure Transmitters



**ROSEMOUNT®**

FISHER-ROSEMOUNT™ Managing The Process Better.™



## Model 1151 Smart Pressure Transmitters

### NOTICE

Read this manual before working with the product. For personal and system safety, and for optimum product performance, make sure you thoroughly understand the contents before installing, using, or maintaining this product.

Within the United States, Rosemount Inc. has two toll-free assistance numbers.

**Customer Central:** 1-800-999-9307 (7:00 a.m. to 7:00 p.m. CST)  
Technical support, quoting, and order-related questions.

**North American Response Center:** 1-800-654-7768 (24 hours a day – Includes Canada)  
Equipment service needs.

For equipment service or support needs outside the United States, contact your local Rosemount representative.

### ⚠ CAUTION

The products described in this document are NOT designed for nuclear-qualified applications.

Using non-nuclear qualified products in applications that require nuclear-qualified hardware or products may cause inaccurate readings.

For information on Rosemount nuclear-qualified products, contact your local Rosemount Sales Representative.

SNF-0004

*May be protected by one or more of the following U.S. Patent Nos. 4,804,958; 4,866,435; 4,878,012; 4,988,990; 5,083,091; 5,094,109; 5,237,285; Des. 317,266; Des. 318,432. Mexico Pats. Pend. 6057,912237. May depend on model. Other foreign patents issued and pending.*

*Rosemount, the Rosemount logotype, SMART FAMILY, and HART are registered trademarks of Rosemount Inc. δ-Cell is a trademark of Rosemount Inc.*

*Hastelloy is a registered trademark of Cabot Corp.*

*Loctite is a registered trademark of Loctite Corporation.*

*Monel is a registered trademark of International Nickel Co.*

*Teflon and Viton are registered trademarks of E.I. du Pont de Nemours & Co.*

*Syltherm and D.C. are registered trademarks of Dow Corning Corp.*

*Neobee M-20 is a registered trademark of Stepan Chemical Co.*

*Aflax is a registered trademark of Asahi Glass Co. Ltd.*

*Kynar is a registered trademark of Pennwalt Inc.*

*Noryl is a registered trademark of General Electric.*

*Fluorolube is a registered trademark of Hooker Chemical Co.*



Fisher-Rosemount satisfies all obligations coming from legislation to harmonize product requirements in the European Union.



# ROSEMOUNT®

**FISHER-ROSEMOUNT™ Managing The Process Better.™**

#### Rosemount Inc.

8200 Market Boulevard  
Chanhassen, MN 55317 USA  
Tel 1-800-999-9307  
Telex 4310012  
Fax (612) 949-7001  
© 1999 Rosemount, Inc.  
<http://www.rosemount.com>



---

# Table of Contents

|                              |  |      |
|------------------------------|--|------|
| <b>SECTION 1</b>             | Using this Manual . . . . .  | 1-1  |
| <b>Introduction</b>          | Models Covered . . . . .   | 1-2  |
| <br>                         |  |      |
| <b>SECTION 2</b>             | Overview . . . . .   | 2-1  |
| <b>Transmitter Functions</b> | Safety Messages . . . . .  | 2-1  |
|                              | Warnings . . . . .   | 2-1  |
|                              | Commissioning the Transmitter on the Bench . . . . .                     | 2-1  |
|                              | Setting Hardware Switches . . . . .                                      | 2-1  |
|                              | Failure Mode Alarm Switch . . . . .                                      | 2-2  |
|                              | Transmitter Security (Write-Protection Switch) . . . . .                 | 2-2  |
|                              | Commissioning the Model 1151 with a<br>HART-Based Communicator . . . . . | 2-3  |
|                              | Wiring Diagrams (Bench Hook-up) . . . . .                                | 2-3  |
|                              | Testing the Equipment and the Loop . . . . .                             | 2-4  |
|                              | Communicator Test. . . . .   | 2-4  |
|                              | Transmitter Test. . . . .  | 2-4  |
|                              | Loop Test . . . . .  | 2-4  |
|                              | Review Configuration Data . . . . .                                      | 2-4  |
|                              | Checking the Transmitter Output . . . . .                                | 2-4  |
|                              | Process Variable . . . . .   | 2-4  |
|                              | Range Points . . . . .   | 2-4  |
|                              | Calibration Overview . . . . .   | 2-5  |
|                              | Wiring Diagrams (Field Hook-up) . . . . .                                | 2-6  |
|                              | Common Functions . . . . .   | 2-7  |
|                              | Setting the Loop to Manual . . . . .                                     | 2-7  |
|                              | Change Non-Output Related Information. . . . .                           | 2-7  |
|                              | Sending Data to the Transmitter . . . . .                                | 2-7  |
|                              | Configure the Analog Output Parameters . . . . .                         | 2-7  |
|                              | Setting Units . . . . .  | 2-7  |
|                              | Reranging . . . . .  | 2-7  |
|                              | Reranging with a Communicator Only . . . . .                             | 2-9  |
|                              | Reranging with a Pressure Input Source and a<br>Communicator . . . . .   | 2-9  |
|                              | Reranging Using the Integral Span and Zero Buttons . . . . .             | 2-10 |
|                              | Setting the Output Type . . . . .  | 2-11 |
|                              | Setting Damping . . . . .  | 2-12 |
|                              | Calibrate the Sensor . . . . .   | 2-12 |
|                              | Digital Trim (Sensor Trim and Analog Output Trim) . . . . .              | 2-12 |
|                              | Sensor Trim. . . . .   | 2-12 |
|                              | Full Trim . . . . .  | 2-12 |
|                              | Zero Trim. . . . .   | 2-13 |
|                              | Systematic Error Correction . . . . .                                    | 2-14 |
|                              | Deciding Whether to Trim the D/A Converter . . . . .                     | 2-15 |
|                              | Digital to Analog Converter Trim . . . . .                               | 2-16 |
|                              | 4–20 mA Analog Output Trim . . . . .                                     | 2-16 |
|                              | 4–20 mA Analog Output Trim Using Other Scale . . . . .                   | 2-16 |
|                              | Advanced Functions . . . . .   | 2-16 |
|                              | Burst Mode . . . . .   | 2-16 |

---

|   |      |
|---|------|
| Saving, Recalling, and Cloning Configuration Data . . . . . | 2-17 |
| Multidrop Communication . . . . .                           | 2-17 |
| Changing a Transmitter Address . . . . .                    | 2-18 |
| Polling a Multidropped Loop . . . . .                       | 2-18 |
| Model 1151 Smart Pressure Transmitter . . . . .             | 2-19 |

**SECTION 3  
Installation**

|  |      |
|--|------|
| Overview . . . . .   | 3-1  |
| Safety Messages . . . . .  | 3-2  |
| Warnings . . . . .   | 3-2  |
| General Considerations . . . . .   | 3-3  |
| Access Requirements . . . . .  | 3-3  |
| Process Flange Orientation . . . . .   | 3-3  |
| Housing Rotation . . . . .   | 3-4  |
| Terminal Side of Electronics Housing . . . . .                               | 3-4  |
| Circuit Side of Electronics Housing . . . . .                                | 3-4  |
| Exterior of Electronics Housing . . . . .                                    | 3-4  |
| Mechanical Considerations . . . . .  | 3-5  |
| Mounting Considerations . . . . .  | 3-7  |
| Mounting Requirements (for Steam, Liquid, Gas) . . . . .                     | 3-7  |
| Taps . . . . .   | 3-7  |
| Drain/Vent Valves . . . . .  | 3-8  |
| Impulse Piping . . . . .   | 3-8  |
| Process Connections . . . . .  | 3-9  |
| Mounting Brackets . . . . .  | 3-10 |
| Electrical Considerations . . . . .  | 3-11 |
| Power Supply . . . . .   | 3-11 |
| Conduit Installation . . . . .   | 3-12 |
| Wiring . . . . .   | 3-12 |
| Grounding . . . . .  | 3-13 |
| Signal Wiring . . . . .  | 3-13 |
| Transmitter Case . . . . .   | 3-13 |
| Grounding Effects . . . . .  | 3-14 |
| Hazardous Locations Certifications . . . . .                                 | 3-15 |
| Environmental Requirements . . . . .   | 3-15 |
| Installation Options . . . . .   | 3-15 |
| Mounting Brackets . . . . .  | 3-15 |
| Analog Meters . . . . .  | 3-15 |
| LCD Meters . . . . .   | 3-16 |
| LCD Meter Configuration . . . . .  | 3-16 |
| Remove the Cover . . . . .   | 3-16 |
| Position the Decimal Point and Select the Meter Function . . . . .           | 3-17 |
| Store the Information . . . . .  | 3-17 |
| Set the Display Equivalent to a 4 mA Signal . . . . .                        | 3-17 |
| Set the Display Equivalent to a 20 mA Signal . . . . .                       | 3-17 |
| Replace the Cover . . . . .  | 3-17 |
| LCD Meter Assembly . . . . .   | 3-17 |
| Terminal Blocks . . . . .  | 3-19 |
| Transient Protection and Filter Terminal Block<br>(OPTION CODE R1) . . . . . | 3-19 |
| Terminal Block Installation . . . . .  | 3-19 |

---

**SECTION 4**  
**Troubleshooting**

Overview ..... 4-1  
Safety Messages ..... 4-1  
    Warnings ..... 4-1  
    Disassembly Procedure ..... 4-5  
        Process Sensor Body ..... 4-5  
        Electrical Housing ..... 4-6  
        Removing the Sensor from the Electrical Housing ..... 4-6  
    Reassembly Procedure ..... 4-6  
        Preliminary Precaution ..... 4-6  
        Connecting the Electrical Housing to the Sensor ..... 4-6  
        Electrical Housing ..... 4-6  
        Process Sensor Body ..... 4-7  
    Optional Plug-in Meters ..... 4-8  
    Sensor Module Checkout ..... 4-8  
    Returning Rosemount Products and/or Materials ..... 4-9

**SECTION 5**  
**Specifications and**  
**Reference Data**

Functional Specifications ..... 5-1  
Performance Specifications ..... 5-7  
Physical Specifications ..... 5-8  
Ordering Information ..... 5-10  
    Parts List ..... 5-19  
    Parts List ..... 5-27  
Specifications and Reference Data for Options ..... 5-30  
    LCD Meter Specifications ..... 5-30  
    Terminal Block Specifications ..... 5-31

**APPENDIX A**  
**HART® Communicator**

Introduction ..... A-1  
Safety Messages ..... A-1  
    Warnings ..... A-1  
Connections and Hardware ..... A-4  
Communicator Keys ..... A-6  
    Action Keys ..... A-6  
    Function Keys ..... A-7  
    Alphanumeric and Shift Keys ..... A-7  
HART Fast Key Sequences ..... A-8  
    HART Fast Key Example ..... A-8  
Menus and Functions ..... A-8  
    Main Menu ..... A-8  
    Online Menu ..... A-9  
Diagnostic Messages ..... A-10

---

|                               |  |      |
|-------------------------------|--|------|
| <b>APPENDIX B</b>             |  |      |
| <b>Model 268 Communicator</b> | Introduction . . . . .                                   | B-1  |
|                               | Connections and Hardware . . . . .                       | B-4  |
|                               | Communicator Keys . . . . .                              | B-5  |
|                               | Dedicated Keys . . . . .                                 | B-5  |
|                               | Alphanumeric and Shift Keys . . . . .                    | B-6  |
|                               | Function Keys . . . . .                                  | B-6  |
|                               | Fast Key Sequences . . . . .                             | B-7  |
|                               | Fast Key Sequence Conventions . . . . .                  | B-7  |
|                               | Fast Key Sequence Examples . . . . .                     | B-7  |
|                               | Diagnostics Messages . . . . .                           | B-8  |
| <br>                          |  |      |
| <b>APPENDIX C</b>             |  |      |
| <b>Retrofitting the</b>       | Introduction . . . . .                                   | C-1  |
| <b>Model 1151 Transmitter</b> | Safety Messages . . . . .                                | C-1  |
|                               | Warnings . . . . .                                       | C-1  |
|                               | Retrofitting Overview . . . . .                          | C-2  |
|                               | Removing the Analog Electronics Assembly . . . . .       | C-2  |
|                               | Installing the Smart Retrofit Kit . . . . .              | C-10 |
|                               | Characterization . . . . .                               | C-13 |
|                               | Before Characterizing the Transmitter . . . . .          | C-13 |
|                               | Characterizing with a Model 275 Communicator . . . . .   | C-13 |
|                               | Characterization with a Model 268 Communicator . . . . . | C-14 |
| <br>                          |  |      |
| <b>APPENDIX D</b>             |  |      |
| <b>Approval Drawings</b>      |  |      |
| <br>                          |  |      |
| <b>GLOSSARY</b>               |  | G-1  |
| <br>                          |  |      |
| <b>INDEX</b>                  |  | I-1  |



## Introduction

### USING THIS MANUAL

This manual provides information on installation, operation, and maintenance of Rosemount® Model 1151 Smart Pressure Transmitters. The rest of this manual is organized into the following sections:

#### **Section 2—Transmitter Functions**

This section describes the Model 1151 software functions, configuration parameters, and other on-line variables.

#### **Section 3—Installation**

This section provides mechanical and electrical installation instructions.

#### **Section 4—Troubleshooting**

This section provides troubleshooting techniques for diagnostic messages associated with the transmitter.

#### **Section 5—Specifications and Reference Data**

This section provides reference and specification data for Model 1151 Smart Pressure Transmitters.

#### **Appendix A—HART® Communicator**

This appendix contains a communicator overview, a HART Communicator menu tree for the Model 1151 Smart Pressure Transmitters, and a table of HART Communicator fast key sequences. A table of diagnostic messages associated with this communicator is also included.

#### **Appendix B—Model 268 Communicator**

This appendix contains a communicator overview, a Model 268 Communicator menu tree for the Model 1151 Smart Pressure Transmitters, and a table of Model 268 fast key sequences. A table of diagnostic messages associated with this communicator is also included.

#### **Appendix C—Retrofitting the Model 1151 Transmitter**

This section describes how the Rosemount Smart Retrofit Kit can be used to retrofit a Model 1151AP, DP, GP, HP, or LT transmitter with 4-20 mA dc linear or square root output.

#### **Appendix D—Approval Drawings**

This appendix contains intrinsic safety drawings.

#### **Glossary**

This section provides brief definitions of the terms used in this manual.

#### **Index**

This section provides a comprehensive index.

## MODELS COVERED

This manual provides basic installation, commissioning, and troubleshooting information for the following Rosemount® Model 1151 Smart Pressure Transmitters:

**Model 1151DP—Differential Pressure Transmitter**

measures differential pressure from 2 inH<sub>2</sub>O to 1,000 psi (0.497 to 6895 kPa).

**Model 1151HP—Differential Pressure Transmitter for High Line Pressures**

provides high line pressure from 10 inH<sub>2</sub>O to 300 psi (2.49 to 2068 kPa).

**Model 1151GP—Gage Pressure Transmitter**

measures gage pressure from 2 inH<sub>2</sub>O to 1,000 psi (0.497 to 41369 kPa).

**Model 1151AP—Absolute Pressure Transmitter**

measures absolute pressure from 10 inH<sub>2</sub>O to 1,000 psi (2.49 to 6895 kPa).

**Model 1151LT—Flange-Mounted Liquid Level Transmitter**

provides precise level and specific gravity measurements from 25 to 2,770 inH<sub>2</sub>O (6.2 to 690 kPa) for a wide variety of tank configurations.

# Transmitter Functions

## OVERVIEW

This section contains information on commissioning and operating Model 1151 Smart Pressure Transmitters. Instructions for setting transmitter switches (prior to installation) and explanations of software functions are provided in this section.

Fast key sequences are listed for each software function. Please refer to Appendices A and B for more information on fast key sequences and other communicator operations.

## SAFETY MESSAGES

### Warnings (⚠)

Procedures and instructions in this section that raise potential safety issues are indicated by a warning symbol (⚠). Refer to the following warning messages before performing an operation preceded by this symbol.

| <b>⚠ WARNING</b>   |
|--|
| Explosions can result in death or serious injury. Before connecting a communicator in an explosive atmosphere, make sure the instruments in the loop are installed in accordance with intrinsically safe or nonincendive field wiring practices. |

### Commissioning the Transmitter on the Bench

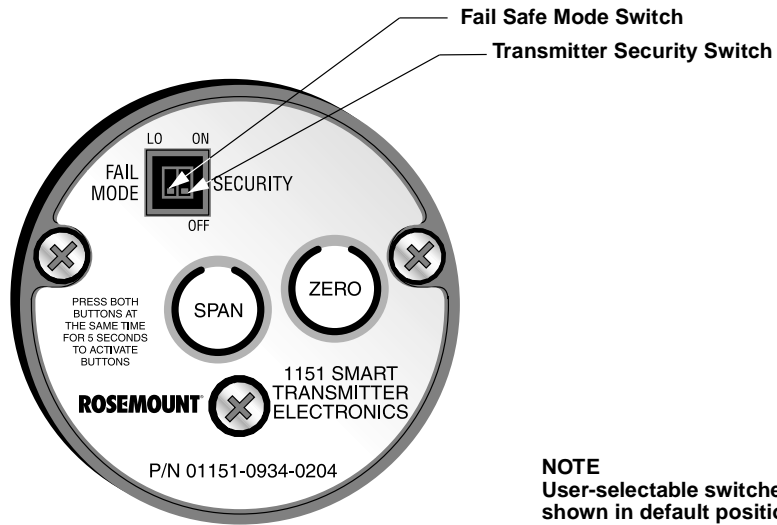
Commissioning consists of testing the transmitter, testing the loop, and verifying transmitter configuration data. Model 1151 Smart Pressure Transmitters may be commissioned either before or after installation. We recommend commissioning the transmitter on the bench before installation. This ensures that all transmitter components are in good working order and heightens familiarity with the device.

To avoid exposing the transmitter electronics to the plant environment after installation, set the failure mode and transmitter security switches during the commissioning stage on the bench.

### Setting Hardware Switches

The Model 1151 Smart Pressure Transmitter contains hardware switches that provide user-selectable operation of the failure mode and transmitter security. The switches are located on the electronics assembly just inside the electronics housing cover, as shown in Figure 2-1.

FIGURE 2-1.  
Transmitter Switch Locations.



**NOTE**  
User-selectable switches are shown in default position

1151-0908A02B

**Failure Mode Alarm Switch**

As part of its normal operation, the Model 1151 Smart continuously monitors its own operation. This automatic diagnostic routine is a timed series of checks repeated continuously.

The electronics faceplate (Part No. 01151-0934-xxxx) has HI and LO user-selectable failure mode settings. If the diagnostic routine detects a failure in the transmitter in analog output, the transmitter either drives its output below 3.8 mA or above 21.0 mA, depending on the position of the failure mode alarm switch.

**NOTE**

With multidrop (digital) output, the analog output remains at 4 mA, even when a diagnostic failure is detected. This is true for both the HI and LO fail mode switch settings. A bit is enabled in the digital word to indicate a diagnostic failure.

**Transmitter Security (Write-Protection Switch)**


Once the transmitter has been configured, it may be desirable to protect the configuration data from changes. The electronics assembly is equipped with a switch labeled SECURITY. Figure 2-1 shows the switch location on the circuit side of the electronics housing. In the ON position, the switch prevents the accidental or deliberate change of configuration data. To enable the sending of configuration data, simply return the transmitter security switch to the OFF position.

**NOTE**

The transmitter security switch must be in the OFF position before configuration changes can be made to the transmitter configuration.

## Commissioning the Model 1151 with a HART-Based Communicator

Before putting the Model 1151 Smart Pressure Transmitter into operation, commission the instrument using a HART-based communicator.

 To commission on the bench, connect a 17 to 45 V dc power supply and a current meter, such as the Rosemount Model 282 Validator. Make connections as shown in Figure 2-2. The power supplied to the transmitter should not drop below the transmitter lift-off voltage. If the transmitter is being configured when the power drops below the lift-off voltage, the configuration information may not be interpreted correctly by the transmitter.

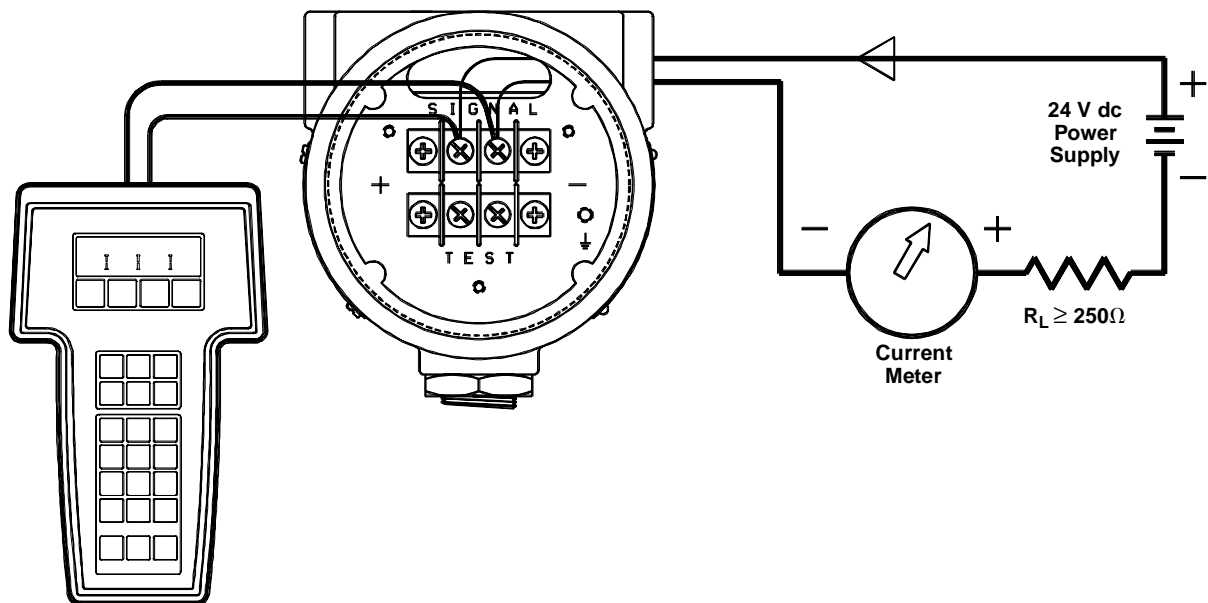
### NOTE

To enable communication, a resistance of at least  $250\ \Omega$  must be present between the communicator loop connection and the power supply.

## Wiring Diagrams (Bench Hook-up)

After the bench equipment is connected as shown in Figure 2-2, turn on the HART-based communicator by pressing the ON/OFF key. The communicator will search for a HART-compatible device and will indicate when the connection is made. If the connection is not made, the communicator will indicate that no device was found. If this occurs, refer to **Section 4 Troubleshooting**.

FIGURE 2-2. Bench Hook-up.



### NOTE

An alternate location to connect an ammeter is on the set of terminals labeled "TEST." Connect the positive lead of the ammeter to the positive test terminal, and the negative lead of the ammeter to the negative test terminal.

1151-1151G05B



## Testing the Equipment and the Loop

### Communicator Test

Test functions verify that the transmitter, the communicator, and the loop are in good working order. Testing is recommended whenever component failure or a problem with loop performance is suspected.

A communicator test is performed to ensure the communicator is working properly. Both the HART Communicator Model 275 and the Rosemount Model 268 Communicator perform self-tests after being turned on. If a problem is detected, the communicator will list a diagnostic message. Refer to Appendices A and B for diagnostic messages associated with the communicator.

### Transmitter Test

|            |            |
|------------|------------|
| HART Comm. | 1, 2, 1, 1 |
| Model 268  | F2, F2     |

Although the Model 1151 Smart Pressure Transmitter performs continuous self-diagnostics, a more extensive diagnostic routine can be initiated with the transmitter test function. The transmitter test routine can identify an electronics failure.

If the transmitter test detects a problem, messages to indicate the source of the problem are displayed.

### Loop Test

|            |         |
|------------|---------|
| HART Comm. | 1, 2, 2 |
| Model 268  | F2, F3  |

The loop test allows verification of the output of the transmitter, the integrity of the loop, and the operation of any recorders or similar devices. If commissioning the transmitter on the bench, repeat this test after the transmitter has been installed in the field.

A reminder appears to set the loop to manual. Do so and proceed. The next display selects a discrete milliampere transmitter output level. To command the transmitter to output 4 mA, for example, select 4 mA. Check the current meter installed in the test loop to verify that it reads 4 mA. If so, end the loop test. If the output is not 4 mA, then the receiving meter is malfunctioning or the transmitter requires a digital trim as described on page 2-12.

### Review Configuration Data

|            |            |
|------------|------------|
| HART Comm. | 1, 5       |
| Model 268  | Review Key |

Review of the transmitter factory configuration data is recommended.

## Checking the Transmitter Output

### Process Variable

|            |    |
|------------|----|
| HART Comm. | 2  |
| Model 268  | PV |

Process variable readings can be obtained in engineering units and milliamperes. If the milliampere display does not agree with the actual loop reading given by a multimeter, a 4–20 mA trim is required.

The last step of start-up and commissioning is to check the transmitter output. Obtain process variable readings in engineering units and milliamperes. If this display does not agree with the actual loop reading given by a multimeter, a 4–20 mA trim is required (see page 2-16).

### Range Points

|            |            |
|------------|------------|
| HART Comm. | 1, 3, 3    |
| Model 268  | F3, F2, F1 |

The Model 1151 Smart 4 and 20 mA range points can be viewed and edited with these fast key sequences.

## Calibration Overview

Complete calibration of the Model 1151 Smart Pressure Transmitter involves the following tasks:

### Configuring the Analog Output Parameters

- Setting process variable units (page 2-7)
- Reranging (page 2-7)
- Setting output type (page 2-11)
- Setting damping (page 2-12)

### Calibrating the Sensor

- Full trim (page 2-12)
- Zero trim (page 2-13)

### Calibrating the 4–20 mA Output

- 4–20 mA output trim (page 2-16) or
- 4–20 mA output trim using other scale (page 2-16)

FIGURE 2-3. Model 1151 Transmitter Data Flow with Calibration Options.

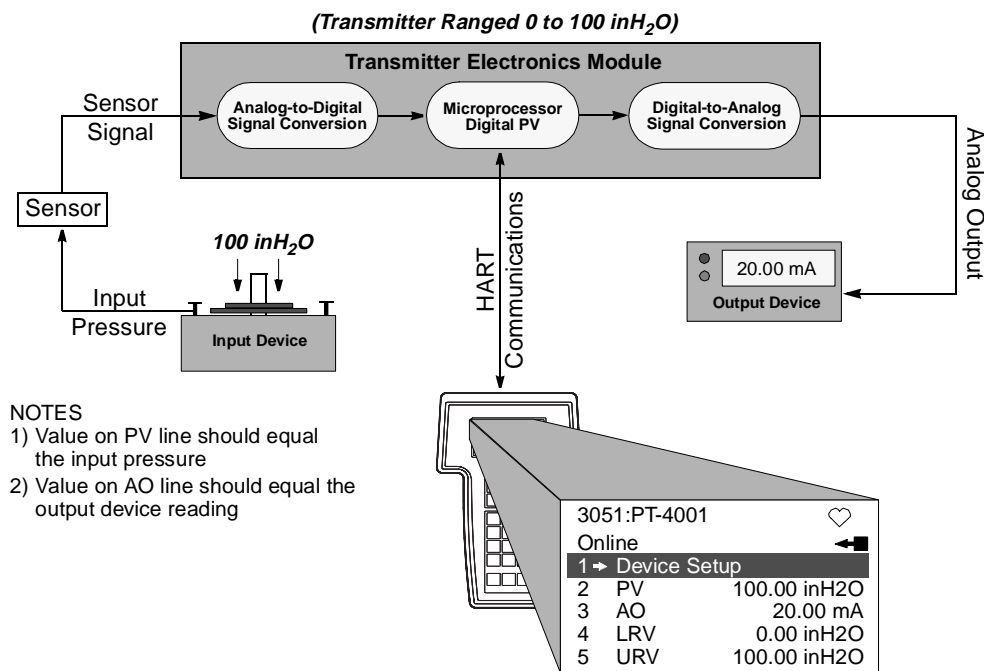


Figure 2-3 illustrates the Model 1151 transmitter data flow. This data flow can be summarized in four major steps:

1. A change in pressure is measured by a change in the sensor output (Sensor Signal).
2. The sensor signal is converted to a digital format that can be understood by the microprocessor (Analog-to-Digital Signal Conversion).
3. Corrections are performed in the microprocessor to obtain a digital representation of the process input (Digital PV).
4. The Digital PV is converted to an analog value (Digital-to-Analog Signal Conversion).

Figure 2-3 also identifies the approximate transmitter location for each calibration task. Note that the data flows from left to right, and a parameter change affects all values to the right of the changed parameter.

Not all calibration procedures should be performed for each Model 1151 transmitter. Furthermore, some procedures are appropriate for bench calibration but should not be performed during field calibration. Table 2-1 identifies the recommended calibration procedures for each type of Model 1151 transmitter for both bench and field calibration.

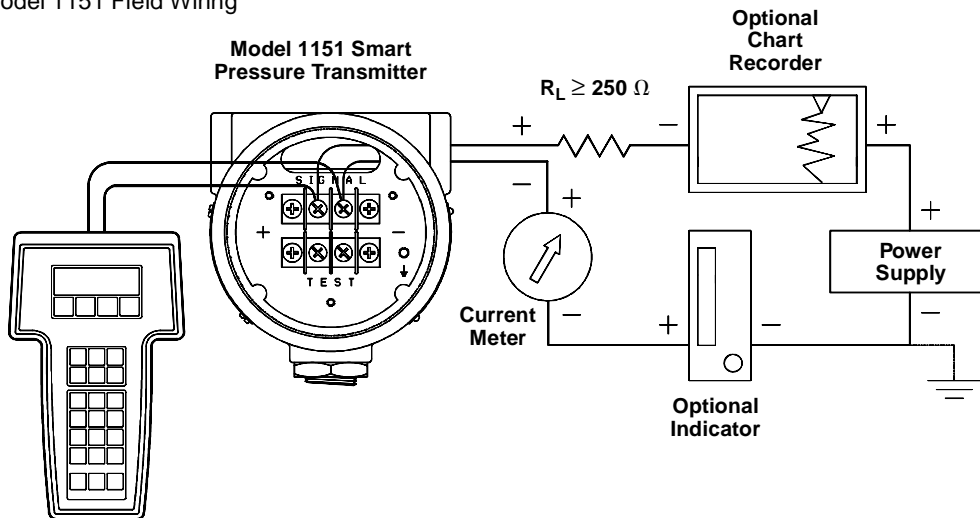
TABLE 2-1. Recommended Calibration Tasks.

| Transmitter  | Bench Calibration Tasks  | Field Calibration Tasks  |
|--|--|--|
| Standard Calibration Tasks<br>1151DP<br>1151GP<br>1151HP<br>1151LT | <ol style="list-style-type: none"> <li>Set output configuration parameters:                             <ol style="list-style-type: none"> <li>Set the Transmitter Range Points.</li> <li>Set the Output Units.</li> <li>Set the Output Type (linear or square root).</li> <li>Set the Damping Value.</li> </ol> </li> <li><i>Optional:</i> Perform a Full Sensor Trim<br/>—Pressure source required.</li> <li><i>Optional:</i> Perform an Analog Output Trim<br/>—Multimeter required.</li> </ol> | <ol style="list-style-type: none"> <li>Reconfigure parameters if necessary.</li> <li>Zero trim the transmitter to compensate for mounting position effects or static pressure effects.</li> </ol>      |
| 1151AP   | Standard Bench Calibration, <b>except step 2:</b><br><ol style="list-style-type: none"> <li><i>Optional:</i> Perform a Full Sensor Trim if equipment is available (accurate <u>absolute</u> pressure source required); otherwise, perform the Low Trim Value section of Full Sensor Trim procedure.</li> </ol>   | <ol style="list-style-type: none"> <li>Reconfigure parameters if necessary.</li> <li>Perform Low Trim Value section of Full Sensor Trim procedure to correct for mounting position effects.</li> </ol> |

**NOTE**  
A HART-based communicator is required for all sensor and output trim procedures.

### Wiring Diagrams (Field Hook-up)

FIGURE 2-4. Model 1151 Field Wiring Diagram.



**NOTE**  
Signal Loop may be grounded at any point or left ungrounded.

**NOTE**  
A HART Interface may be connected at any termination point in the loop. Signal loop must have 250 ohms minimum load for communications.



## Common Functions

### Setting the Loop to Manual

The following tasks are a common part of a transmitter commissioning.

When preparing to send or request data that would disrupt the loop or change the output of the transmitter, set the loop to manual. Both the HART Communicator Model 275 and the Rosemount Model 268 will prompt for this setting when necessary. Keep in mind that simply acknowledging this prompt does not set the loop to manual. It is only a reminder; the loop must be set to manual as a separate operation.

### Change Non-Output Related Information

The Model 1151 Smart contains several configuration parameters that do not directly affect the transmitter output. These parameters include:

- Date
- Descriptor
- Message
- Meter type

### Sending Data to the Transmitter

| HART Comm. | Note   |
|------------|--------|
| Model 268  | F3, F4 |

Whenever transmitter configuration data is updated with a HART-based communicator, the entered data must be sent to the transmitter memory.

#### NOTE

Depending on the task, an option to enter the data (or end changes and enter the data) will appear at the end of the configuration function. Follow the on-screen prompts to complete the send data function.

Review the transmitter memory to ensure that configuration changes have been entered.

## Configure the Analog Output Parameters

### Setting Units

| HART Comm. | 1, 3   |
|------------|--------|
| Model 268  | F3, F2 |

By setting the output units, a process can be monitored using the specified units. This is important if a plant uses units which differ from those preset by Rosemount Inc. Output units can be selected from among 14 output options:

- inH<sub>2</sub>O
- inHg
- ftH<sub>2</sub>O
- mmH<sub>2</sub>O
- mmHg
- psi
- bar
- mbar
- g/cm<sup>2</sup>
- kg/cm<sup>2</sup>
- Pa
- kPa
- torr
- atm

## Reranging

One of the most common configuration tasks involves reranging the transmitter 4 and 20 mA points.

Reranging matches the transmitter range points with the applied process pressures. It can be performed three ways: using the communicator only, using the communicator and a reference pressure, or using the integral zero and span buttons and a reference pressure.

To decide which method is appropriate, consider the following:

- Reranging with only the communicator changes the analog 4 and 20 mA points independently without a pressure input.

This means that when you change either the 4 or 20 mA setting, you also change the span. For instance:

If the transmitter is ranged so that

$$\begin{aligned}4 \text{ mA} &= 0 \text{ inH}_2\text{O}, \text{ and} \\20 \text{ mA} &= 100 \text{ inH}_2\text{O},\end{aligned}$$

and you change the 4 mA setting to 50 inH<sub>2</sub>O using the communicator only, the new settings are:

$$\begin{aligned}4 \text{ mA} &= 50 \text{ inH}_2\text{O}, \text{ and} \\20 \text{ mA} &= 100 \text{ inH}_2\text{O}.\end{aligned}$$

Note that the span was also changed from 100 inH<sub>2</sub>O to 50 inH<sub>2</sub>O, while the 20 mA setpoint remained at 100 inH<sub>2</sub>O.

To obtain reverse output, simply set the 4 mA point at a greater numerical value than the 20 mA point. Using the above example, setting the 4 mA point at 100 inH<sub>2</sub>O and the 20 mA point at 0 inH<sub>2</sub>O will result in reverse output.

---

**NOTE**

The 4 and 20 mA output is based on the transmitter's existing digital calibration. Before reranging with the keypad, make sure the transmitter is correctly interpreting the process variable input. To match the transmitter's reading in engineering units to plant standard, use the sensor trim function under "Digital Trim" in this section.

---

- Reranging with a pressure input and the communicator maintains the same analog span.
- Reranging with a pressure input and the zero and span buttons maintains the same analog span.

For instance, if the transmitter is ranged so that:

$$\begin{aligned}4 \text{ mA} &= 0 \text{ inH}_2\text{O}, \text{ and} \\20 \text{ mA} &= 100 \text{ inH}_2\text{O},\end{aligned}$$

and you then change the 4 mA setting to 50 inH<sub>2</sub>O using the communicator (or buttons) and a pressure input, the new settings are:

$$\begin{aligned}4 \text{ mA} &= 50 \text{ inH}_2\text{O} \\20 \text{ mA} &= 150 \text{ inH}_2\text{O}\end{aligned}$$

The 100 inH<sub>2</sub>O span is maintained.

It is also important to note that when using a pressure source, the 4 and 20 mA setpoints are based on the transmitter's interpretation of the pressure input provided. It is possible that when a plant standard is input, the transmitter reads it as a slightly different value. Although the 4 and 20 mA setpoints will operate properly within these applied settings, the transmitter's digital output in engineering units may indicate a slightly different value.

The sensor trim function under "Digital Trim" can be used to match the transmitter's reading in engineering units to your plant standard, thereby eliminating any discrepancy.

---

**NOTE**

Reranging only the 4 mA or the 20 mA with a pressure input will maintain the initial span width.

---

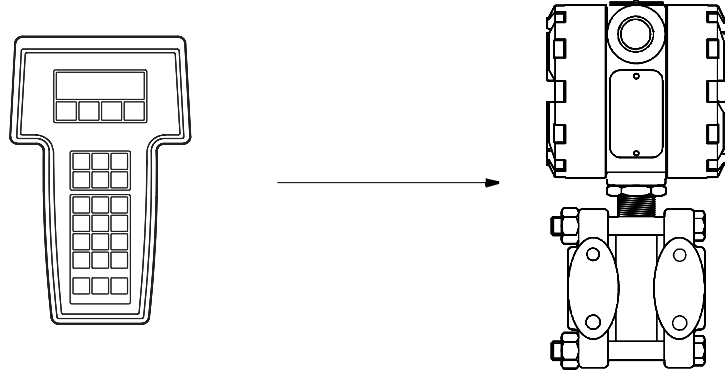
**NOTE**

Do not rearer the transmitter such that the 4 and 20 mA range points—upper range value (URV) and lower range value (LRV)—are outside the high and low digital sensor trim values. To optimize performance, the digital trim span should be equal to or slightly greater than the 4–20 mA span.

**Reranging with a Communicator Only**

|            |                    |
|------------|--------------------|
| HART Comm. | 1, 2, 3, 1, 1      |
| Model 268  | F3, F2, F1, F3, F1 |

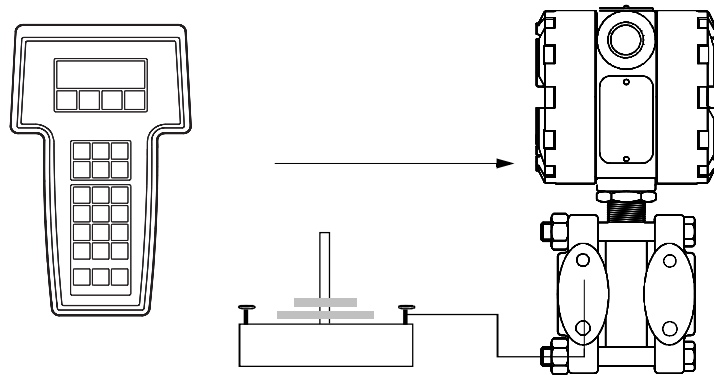
Reranging with the keypad and no pressure input changes the 4 and 20 mA points independently.



**Reranging with a Pressure Input Source and a Communicator**

|            |                    |
|------------|--------------------|
| HART Comm. | 1, 2, 3, 1, 2      |
| Model 268  | F3, F2, F1, F3, F2 |

Reranging with a pressure input source and the communicator or the zero and span buttons allows you to maintain the same analog span.

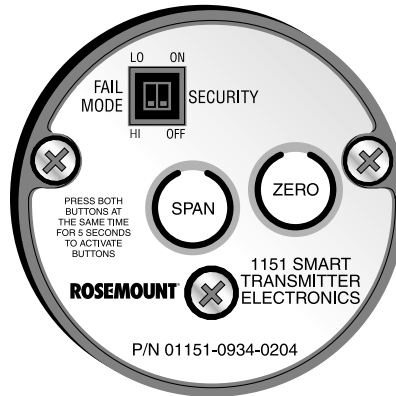


To rerange with a reference pressure, apply the desired pressure input to represent the 4 or 20 mA point. Allow the variable reading to stabilize for approximately ten seconds. Press either the 4 mA or 20 mA to make this pressure value either point.

### Reranging Using the Integral Span and Zero Buttons

It is also possible to rerange the transmitter using the span and zero buttons located within the circuit side of the electronics housing on the electronics faceplate, as shown in Figure 2-5.

FIGURE 2-5. Model 1151 Electronics Faceplate.



**NOTE**  
User-selectable switches are shown in default position.

1151-0908A02A

Use the following steps to rerange using the integral span and zero buttons:

1. Using a pressure source with an accuracy three to ten times the desired calibrated accuracy, apply a pressure equivalent to the lower calibrated value to the high side of the transmitter.
2. Remove the circuit side cover to expose the span and zero buttons. Hold both the span and zero buttons down simultaneously for at least five seconds to activate the controls. The buttons remain active for 15 minutes. After 15 minutes the buttons must be reactivated by pressing simultaneously and holding again.
3. Press the zero button for five seconds to set the 4 mA point. Verify that the output is 4 mA.
4. Apply a pressure equivalent to the higher calibrated value to the high side of the transmitter.
5. Press the span button for five seconds to set the 20 mA point. Verify that the output is 20 mA.

---

#### NOTE

Both the lower and upper range values must fall within the lower and upper range limits of the sensor module, and meet the minimum and maximum span criteria allowed by the transmitter.

---

**Setting the Output Type**

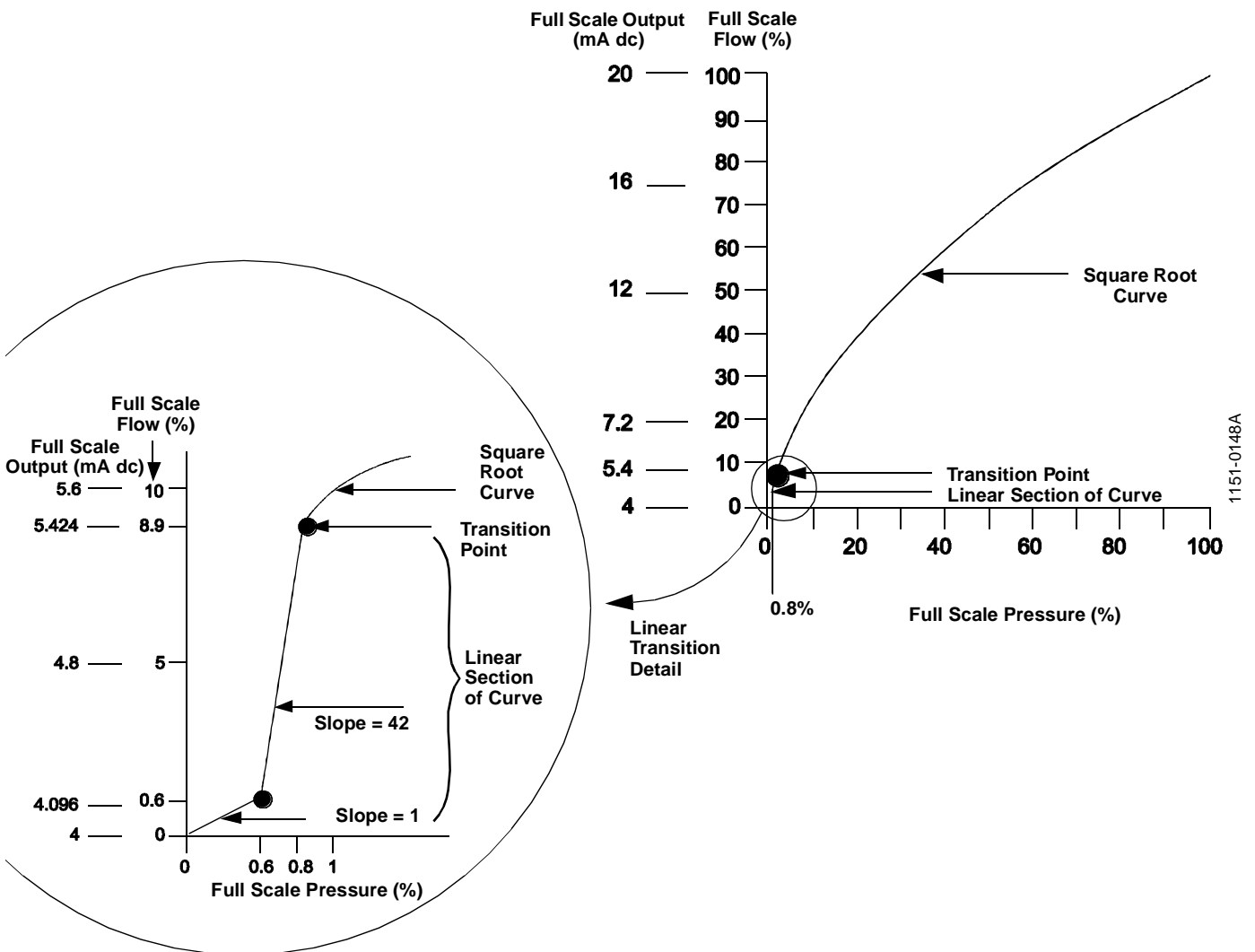
|            |                |
|------------|----------------|
| HART Comm. | 1, 3, 5        |
| Model 268  | F3, F2, F1, F1 |

When the square root output option is active the Model 1151 analog output is proportional to flow. To avoid the extremely high gain that results as the input approaches zero, the Model 1151 automatically switches to a linear output in order to ensure a more stable output near zero. Figure 2-6 illustrates this transition point.

The transition from linear to square root is not adjustable. It occurs at 0.8% of ranged pressure input or 9.0% of full-scale flow output in transmitters with Revision 5.2. software. In earlier software, the transition point occurred at 4.0% of ranged pressure input, or 20% of full scale flow output.

The transition from linear to square root output is smooth, with no step change or discontinuity in output.

FIGURE 2-6. Square Root Output Transition Point.



From 0.0 percent to 0.6 percent of the ranged pressure input, the slope of the curve is unity ( $y = x$ ). This allows accurate calibration near zero. Greater slopes would cause large changes in output for small changes at input. From 0.6 percent to 0.8 percent, the slope of the curve equals 42 ( $y = 42x$ ) to achieve continuous transition from linear to square root at the transition point.

### Setting Damping

|            |            |
|------------|------------|
| HART Comm. | 1, 3, 6    |
| Model 268  | F3, F2, F2 |

The Model 1151 Smart Pressure Transmitter has electronic damping that can increase the response time of the transmitter to smooth the output when there are rapid input variations. High damping values filter out process noise, but response time is decreased. Low damping values increase response time, but process noise can also be detected.

For Model 1151 Smart Pressure Transmitter transmitters, damping values may be set in 0.1 second increments from 0 to 16.0 seconds. The factory default damping value is 0.2 seconds (0.4 seconds for Range 3). Damping values for inert-filled sensors are slightly higher.

### Calibrate the Sensor

#### Digital Trim (Sensor Trim and Analog Output Trim)

In order to understand the digital trim function, it is necessary to understand that smart transmitters operate differently from conventional analog transmitters. Smart transmitters are factory characterized, which involves comparing a pressure input with the output of each transmitter's sensor module. The information obtained in the comparison is stored in the sensor module EEPROM during the characterization process. In operation, the transmitter uses this information to produce a process variable output, in engineering units, dependent on the pressure input. The digital trim function allows corrections to be made to this factory-stored curve.

The digital trim procedure is a two-step process. The first step, called sensor trim, consists of matching the digital process variable reading of the transmitter to a precision pressure input. The second step, called 4–20 mA trim, consists of adjusting the output electronics.

This procedure should not be confused with reranging. Although you can still match a pressure input to a 4 or 20 mA output through a reranging function, you have not affected the transmitter's interpretation of that input. A *sensor trim* allows you to alter the transmitter's interpretation of the input signal. A *4–20 mA analog output trim* allows you to alter the transmitter's conversion of that interpretation into an analog 4–20 mA output.

The transmitter can only be as accurate as the equipment used to perform the digital trim. Use precise equipment under stable, ambient conditions for best results. If such equipment is not available, it may be better to return the transmitter to a local Rosemount service center for verification of the trim values. To eliminate the possibility of over-trimming the transmitter, the Model 1151 will accept only trim values that are within 5 percent of its original characterization.

#### Sensor Trim

The sensor may be trimmed in two ways: full trim and zero trim. They vary in complexity, and their use is application-dependent.

#### Full Trim

|            |                    |
|------------|--------------------|
| HART Comm. | 1, 2, 3, 3         |
| Model 268  | F4, F4, F3, F2, F1 |

A **full trim** is a two-point sensor calibration where two end-point pressures are applied, and all output is linearized between them. To start the procedure, connect the communicator and a pressure input source of at least three times greater accuracy than the Model 1151 Smart Transmitter as shown in Figure 2-7. Always let the variable stabilize for 10 seconds after application of the pressure source before taking its reading.

---

#### NOTE

The Model 1151 Smart Pressure Transmitter allows approximately a 5.0% URL deviation from the characterized curve established at the factory.

---

**NOTE**

A full trim requires a pressure source at least three times more accurate than the transmitter. For best accuracy, make sure the applied pressure is equal to or slightly less than the desired 4 mA setpoint, or equal to or slightly greater than the 20 mA setpoint.

The last trim/input values used will be displayed briefly. The engineering units shown match those selected under configuration or in transmitter characterization.

In selecting the pressure input values, the low and high values should be equal to or outside the 4 and 20 mA points. Do not attempt to obtain reverse output by reversing the high and low points.

**The low trim value should be trimmed first.** This provides a stable reference for additional sensor trim adjustment. Adjustment of the low trim value provides an offset correction to the factory-established characterization curve. Adjustment of the high trim value provides a slope or gain correction to the characterization curve based on the low trim value. In neither case is the factory-established characterization curve changed by this procedure. The trim values allow optimized performance over a specified measuring range at the calibration temperature.

**Zero Trim**

|                   |                    |
|-------------------|--------------------|
| <b>HART Comm.</b> | 1, 2, 3, 3, 1      |
| <b>Model 268</b>  | F3, F2, F1, F3, F2 |

A **zero trim** is a simpler, one-point adjustment. It must be zero-based (in other words, within 3.0% of true zero) and it may be performed when an exact pressure source is not available for the second pressure needed in a full trim.

It is useful for compensating for mounting position effects or for zero shifts due to static pressure in differential pressure applications. However, since this correction maintains the slope of the characterization curve, it should not be used in place of a full trim over the full sensor range.

Zero trim is best performed with the transmitter installed in its final mounting position with static pressure applied (or no pressure for a gage transmitter).

**NOTE**

Because a zero trim must be zero-based, it generally should not be used with Model 1151 Absolute Pressure Transmitters. Absolute pressure transmitters reference absolute zero. To correct mounting position effects on a Model 1151 Absolute Pressure Transmitter, perform a low trim within the full sensor trim function. The low trim function provides a “zero” correction similar to the zero trim function but it does not require the input to be zero based.

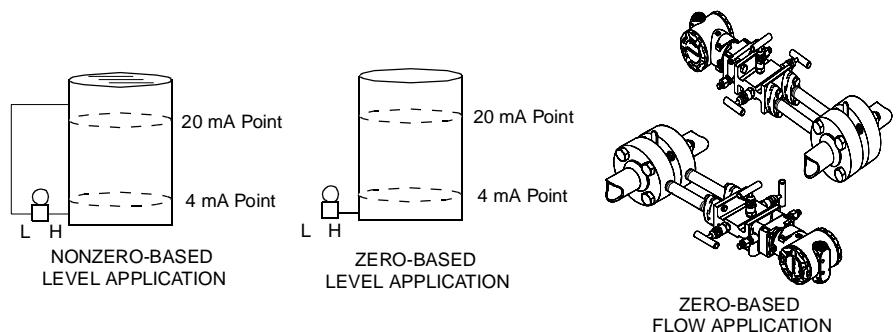
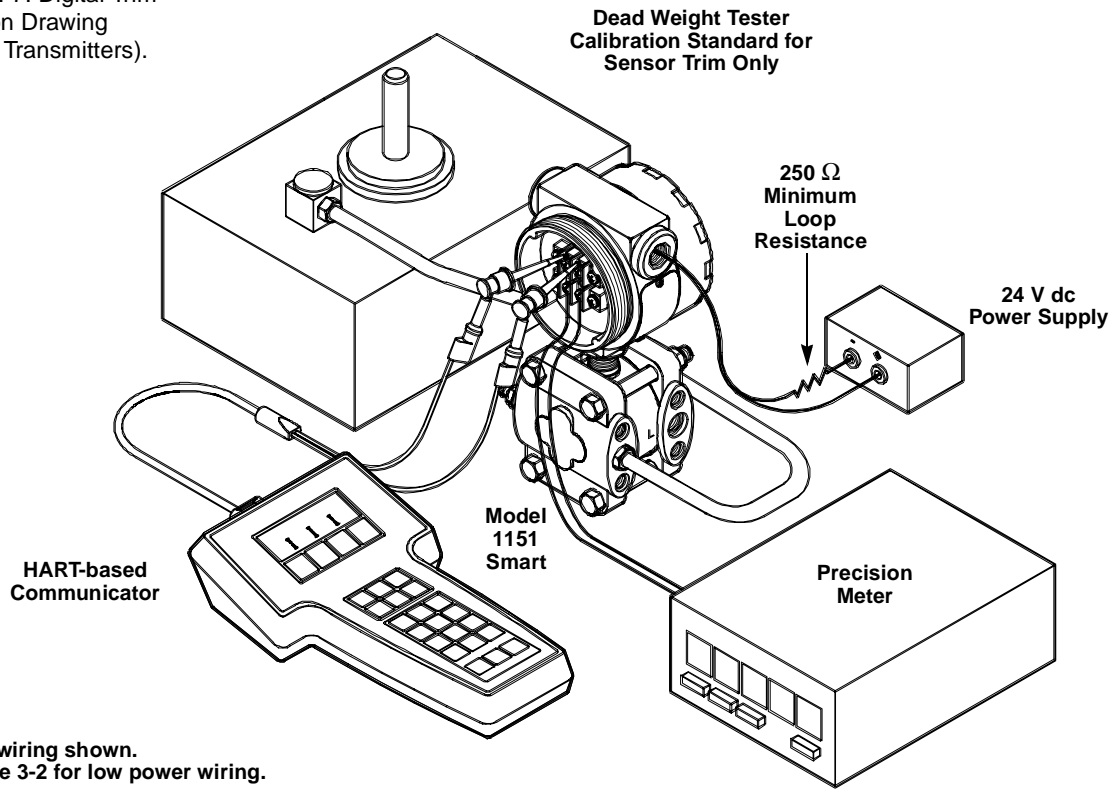


FIGURE 2-7. Digital Trim Connection Drawing (4–20 mA Transmitters).



**NOTE**  
4–20 mA wiring shown.  
See Figure 3-2 for low power wiring.

1151-1151A07A

**Systematic Error Correction**

One feature of full trim is the ability to use it to improve the Model 1151DP or HP performance by correcting for systematic error because of static pressure.

**NOTE**

Corrections can only be made in linear mode. Switch from square-root mode to linear mode if necessary.

High static pressure causes a systematic span shift in the transmitter. It is linear with static pressure and is easily corrected by performing a *full trim*. Table 2-1 shows the amount of systematic span shift for Range Codes 3 through 8.

| Range Code | 316L SST              | Hastelloy® | Monel  |
|------------|-----------------------|------------|--------|
| 3          | -1.75%                | -1.0%      | -1.00% |
| 4          | -0.87% <sup>(1)</sup> | -0.60%     | -0.50% |
| 5          | -0.81% <sup>(1)</sup> | -0.70%     | -0.75% |
| 6          | -1.45% <sup>(1)</sup> | -1.45%     | -1.45% |
| 7          | -1.05% <sup>(1)</sup> | -1.05%     | -1.05% |
| 8          | -0.55%                | -0.55%     | -0.55% |

(1) Applies also to Model 1151HP.

Correction for systematic error is made by simply calculating a correction factor for the high trim and low trim and inputting this correction into the transmitter.



The following example illustrates the correction procedure:

A Model 1151DP 4 (Range 4) with 316L SST isolating diaphragms is to be used in an application where the static line pressure is 1,200 psi. The transmitter is reranged (as stated in **Reranging with a Pressure Input Source and a Communicator** on page 2-9) so that the transmitter output is 4 mA at 50 inH<sub>2</sub>O and 20 mA at 150 inH<sub>2</sub>O.

To correct for systematic error due to static line pressure, use the following formulas to determine a corrected value for Low Trim and High Trim.

$$\text{Low Trim (LT)} = \text{LRV} + \text{S (LRV) P}$$

Where LT = Corrected Low Trim Value at Atmosphere  
 LRV = Lower Range Value at Pressure P = 50 inH<sub>2</sub>O  
 S = -(Span Shift from Table 2-1) = -0.0087/1000 psi  
 P = Static Line Pressure = 1200 psi

$$\text{High Trim (HT)} = \text{URV} + \text{S (URV) P}$$

Where HT = Corrected High Trim Value at Atmosphere  
 URV = Upper Range Value at Pressure P = 150 inH<sub>2</sub>O  
 S = -(Span shift from Table 2-1) = -0.0087/1000 psi  
 P = Static Line Pressure = 1200 psi

In this example:

$$\text{URV} = 150 \text{ inH}_2\text{O}$$

$$\text{LRV} = 50 \text{ inH}_2\text{O}$$

$$\text{S} = +0.0087/1000 \text{ psi}$$

$$\text{P} = 1200$$

$$\text{LT} = 50 + (0.0087/1000)(50)(1200)$$

$$\text{LT} = 50.53 \text{ inH}_2\text{O}$$

$$\text{HT} = 150 + (0.0087/1000)(150)(1200)$$

$$\text{HT} = 151.58 \text{ inH}_2\text{O}$$

#### Entering Corrected Values

To input the corrected values for the Low Trim and High Trim, perform a full trim as explained on page 2-12. When applying the low and high pressure values, edit the pressure reading and enter your corrected Low and High Trim values as in the following example:

Low trim:

Apply—50 inH<sub>2</sub>O

Enter—50.53

High trim:

Apply —150 inH<sub>2</sub>O

Enter—151.58

#### Deciding Whether to Trim the D/A Converter

After the microprocessor conditions the sensor signals, it outputs a digital word. The digital-to-analog (D/A) output circuitry converts the word to an analog signal for the 4–20 mA communications line. It may be necessary to check and trim this circuitry after a period of time. The 4–20 mA output trim function can also be used to make adjustments to allow for peculiarities of a particular readout device in the loop.

To determine whether the output must be trimmed, connect the HART-based communicator and a precision milliammeter capable of reading  $\pm 1$  micromole in the loop as shown in Figure 2-7.

Next, perform a loop test as described on page 2-4. Follow the loop test procedure and set the transmitter to a 4 mA output. Then check the ammeter. The reading should be within  $\pm 3 \mu\text{A}$  of 4 mA.

Then set the transmitter to a 20 mA output and check the milliammeter. The reading should be within  $\pm 3 \mu\text{A}$  of 20 mA. The output should be trimmed if the values on the meter exceed this tolerance range.

When trimming the output, adjustments are made to the output circuitry. The appropriate shift will be made for all intermediate points between 4 and 20 mA.

The communicator will allow the D/A converter to be trimmed by using a current meter or voltage meter. When using a current meter, follow the sequence outlined in **4–20 mA Analog Output Trim**. When using a voltage meter or a meter whose display does not read out in 4–20 mA, follow the sequence outlined under **4–20 mA Analog Output Trim Using Other Scale**.

## Digital to Analog Converter Trim

### 4–20 mA Analog Output Trim

|            |                    |
|------------|--------------------|
| HART Comm. | 1, 2, 3, 2, 1      |
| Model 268  | F4, F4, F3, F1, F1 |

It may be necessary to calibrate the current output circuitry after a period of time and use. The 4–20 mA output trim function can also be used to make adjustments to allow for peculiarities of a particular readout device in the loop.

A 4–20 mA output trim adjusts the transmitter milliampere output to match a plant's current standard. Use this procedure when trimming the converter using a current meter.

### 4–20 mA Analog Output Trim Using Other Scale

|            |                    |
|------------|--------------------|
| HART Comm. | 1, 2, 3, 2, 2      |
| Model 268  | F4, F4, F3, F1, F2 |

To trim the output using a voltage or other meter, connect the meter across a resistor in the loop. For best accuracy, use a precision resistor. The scaling function may be used if the meter displays other units, such as 0–100%.

---

#### NOTE

If a resistor is added to the loop, before proceeding, ensure that the power supply is sufficient to power the transmitter to a 20 mA output with the additional loop resistance.

---

## Advanced Functions

### Burst Mode

|            |               |
|------------|---------------|
| HART Comm. | 1, 4, 3, 4, 3 |
| Model 268  | F4, F4, F1    |

When the Model 1151 Smart is configured for burst mode, it provides faster digital communication from the transmitter to the control system by eliminating the time required for the control system to request information from the transmitter.

Burst mode is compatible with use of the analog signal. Because HART protocol features simultaneous digital and analog data transmission, the analog value can drive other equipment in the loop while the control system is receiving the digital information. Burst mode applies only to the transmission of dynamic data (pressure and temperature in engineering units, pressure in percent of range, and/or analog output in mA or V), and does not affect the way other transmitter data is accessed.

Access to information other than dynamic transmitter data is obtained through the normal poll/response method of HART communication. A HART-based communicator or the control system may request any of the information that is normally available while the transmitter is in burst mode. Between each message sent by the transmitter, a short pause allows the HART-based communicator or a control system to initiate a request. The transmitter will receive the request, process the response message, and then continue “bursting” the data approximately three times per second.

### Saving, Recalling, and Cloning Configuration Data

|            |                      |
|------------|----------------------|
| HART Comm. | Left Arrow, 3 (Note) |
| Model 268  | F4, F4, F1           |

Data that was entered off-line can be stored in the communicator memory and downloaded to other transmitters later. Data also can be copied from a transmitter in order to be sent to other transmitters in a process known as “cloning.” This is especially useful if when working with a large number of transmitters that require the same configuration data.

---

#### NOTE

The HART Communicator Model 275 requires the use of the Transfer Menu to move data between the transmitter memory and the communicator. This menu is available from the Main Menu of the HART Communicator. Press the left arrow to move from the Online Menu to the Main Menu. Press 3 from the Main Menu to access the Transfer Menu.

---

A HART-based communicator may be used to transfer data between transmitters of the same model type.

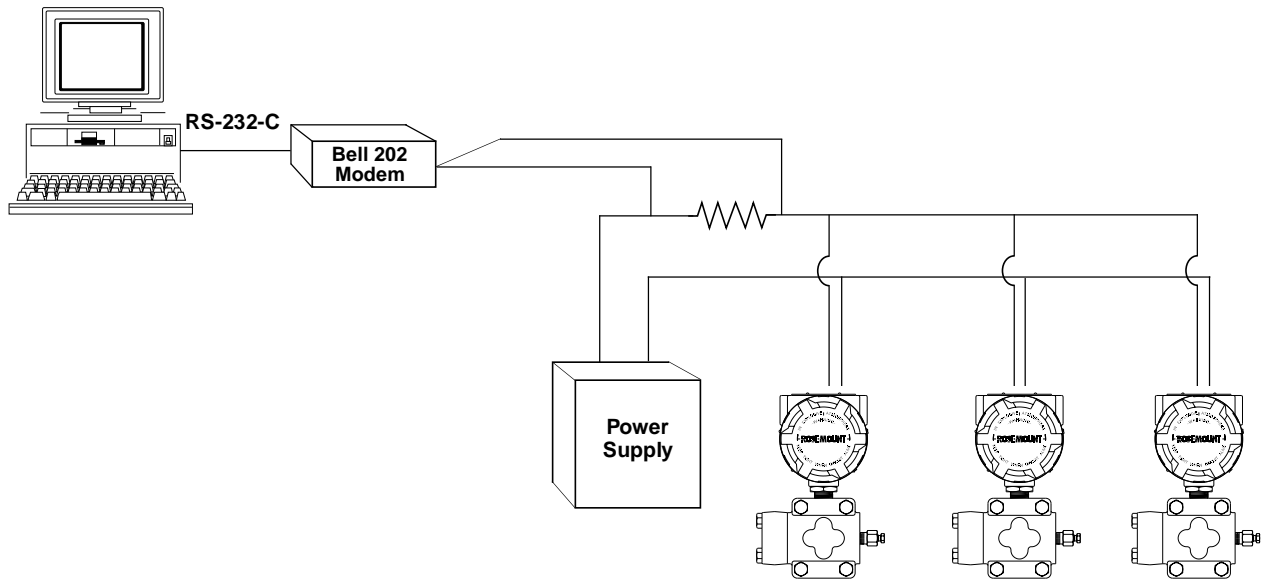
### Multidrop Communication

Multidropping transmitters refers to the connection of several transmitters to a single communications transmission line. Communication between the host and the transmitters takes place digitally with the analog output of the transmitters deactivated. Many of the Rosemount SMART FAMILY transmitters can be multidropped. With the HART smart communications protocol, up to 15 transmitters can be connected on a single twisted pair of wires or over leased phone lines. Note that burst mode operation is not compatible with multidrop communications.

The application of a multidrop installation requires consideration of the update rate necessary from each transmitter, the combination of transmitter models, and the length of the transmission line. Multidrop installations are not recommended where intrinsic safety is a requirement. Communication with the transmitters can be accomplished with commercially available Bell 202 modems and a host implementing the HART protocol. Each transmitter is identified by a unique address (1-15) and responds to the commands defined in the HART protocol.

Figure 2-8 shows a typical multidrop network. This figure is not intended as an installation diagram. Contact Rosemount product support with specific requirements for multidrop applications.

FIGURE 2-8. Typical Multidrop Network.



1151-1151B05B 1151-0087A

HART-based communicators can test, configure, and format a multidropped Model 1151 in the same way as it can a Model 1151 in a standard point-to-point installation.

**NOTE**

The Model 1151 Smart Pressure Transmitter is set to address 0 at the factory, allowing it to operate in the standard point-to-point manner with a 4–20 mA output signal. To activate multidrop communication, the transmitter address must be changed to a number between 1 and 15 (inclusive). This change deactivates the 4–20 mA analog output, sending it to 4 mA. It also disables the failure mode alarm signal, which is controlled by the upscale/downscale switch.

**Changing a Transmitter Address**

|                   |                    |
|-------------------|--------------------|
| <b>HART Comm.</b> | 1, 4, 3, 4, 1      |
| <b>Model 268</b>  | F1, F4, F4, F2, F3 |

To change the address of a multidropped transmitter, follow these fast key sequences. To activate multidrop communication, the transmitter address must be changed to a number from 1 to 15.

**Polling a Multidropped Loop**

|                   |                         |
|-------------------|-------------------------|
| <b>HART Comm.</b> | Left Arrow, 5, 1 (note) |
| <b>Model 268</b>  | F1, F4, F4, F2, F3      |

Polling a multidropped loop determines the model, address, and number of transmitters on the given loop.

**NOTE**

The HART Communicator Model 275 requires the use of the Utility Menu to perform an auto poll. This menu is available from the Main Menu of the HART Communicator. Press the left arrow to move from the Online Menu to the Main Menu. Press 5 from the Main Menu to access the Utility Menu.



**HARDWARE SELECTABLE INFORMATION:**

Failure Mode:  
Transmitter Security:

High  
 Off

Low  
 On

**SIGNAL SELECTION:**

4–20 mA with simultaneous digital signal based on *HART* protocol

Burst mode of *HART* digital process variable<sup>(1)</sup>

Burst mode output options:

Primary variable in engineering units

Primary variable in percent of range

All dynamic variables in engineering units and the primary variable mA value

Multidrop Communication<sup>(2)</sup>

Choose transmitter address (1-15)<sup>(3)</sup>: \_\_\_\_\_

(1) These options are available with Revision 5.1 and greater software.

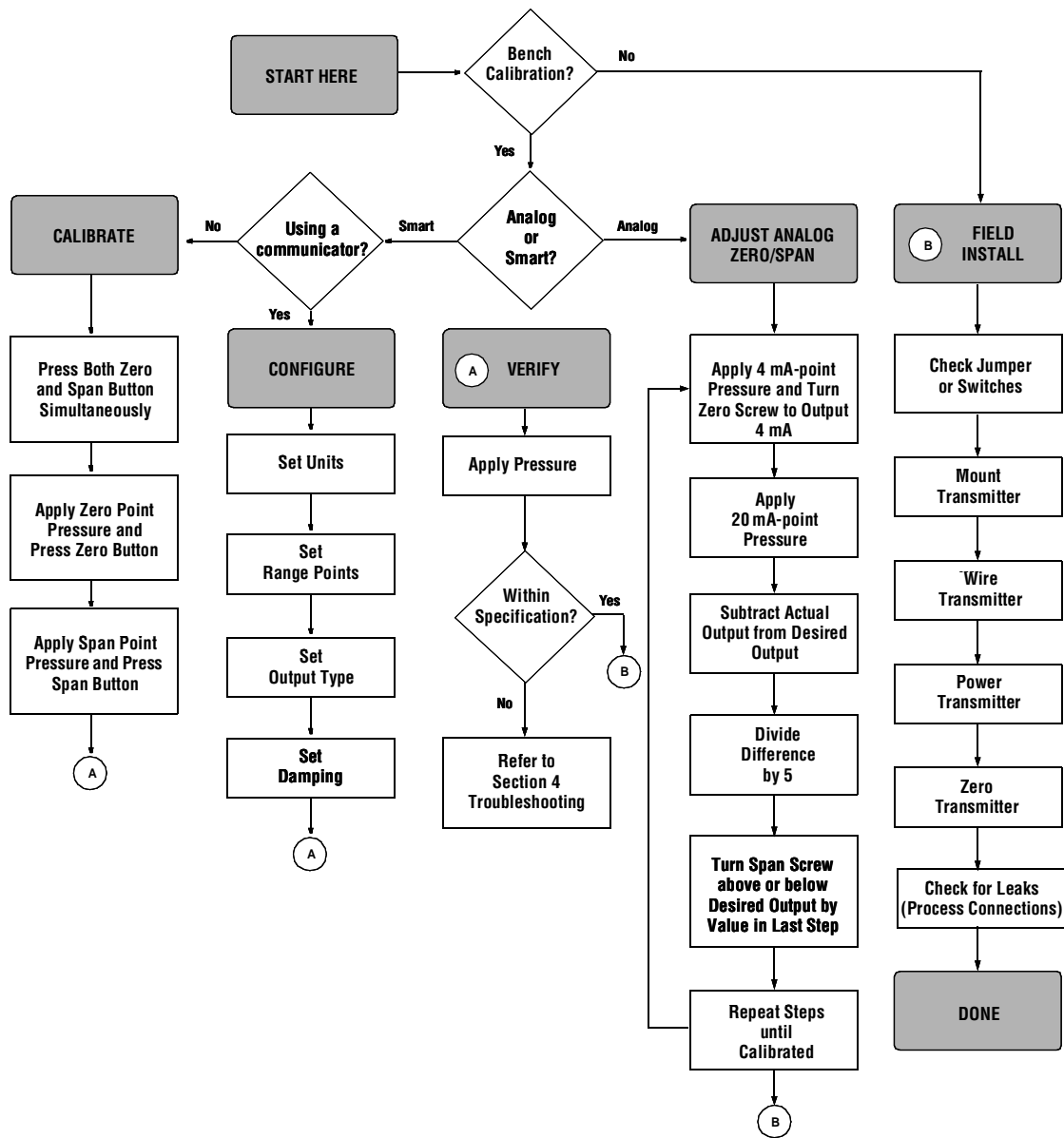
(2) This option fixes the transmitters analog output at 4 mA.

(3) Default transmitter address is 1 if multidrop communication is selected.

OVERVIEW

This section is designed to guide you through a successful Model 1151 installation. This section contains an installation flow chart; safety messages; general, mechanical, mounting, and electrical installation information; as well as installation guidance for optional parts. Dimensional drawings for each Model 1151 variation and mounting configuration are included.

FIGURE 3-1. Model 1151 Installation Flowchart.



## SAFETY MESSAGES

### Warnings (⚠)

Procedures and instructions in this section that raise potential safety issues are indicated by a warning symbol (⚠). Refer to the following warning messages before performing an operation preceded by this symbol.

#### **⚠ WARNING**

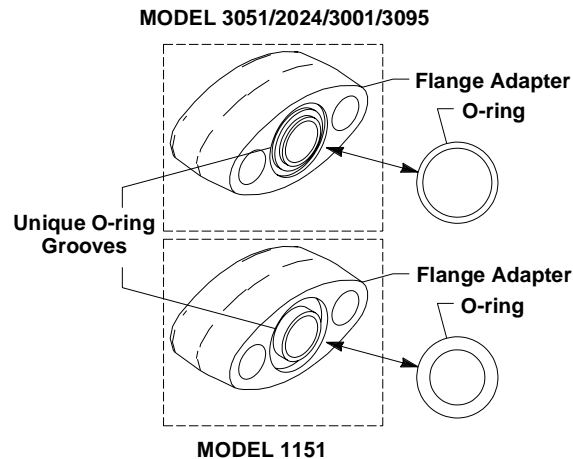
- Explosions can result in death or serious injury. Before connecting a communicator in an explosive atmosphere, make sure the instruments in the loop are installed in accordance with intrinsically safe or nonincendive field wiring practice.
- Process leaks can cause death or serious injury. Install and tighten all four flange bolts before applying pressure, or process leakage may result. Attempting to remove the flange bolts while the transmitter is in service may cause process fluid leaks.
- All explosion-proof, flameproof, and dust-ignition-proof installations require insertion of conduit plugs in all unused openings with a minimum of 40 ft-lb (54 N-m) of torque. This will maintain five full threads of engagement.
- When adding a meter option to a Model 1151 with an Option Code R1 or R2 terminal block, make sure to change to cemented meter covers with a glass window. Make sure a sticker is located inside the cover that indicates a “cemented cover.” This cover is required to maintain explosion-proof approval.
- Explosions can cause death or serious injury. Do not remove the instrument cover in explosive atmospheres when the circuit is alive.
- Explosions can cause death or serious injury. To meet hazardous location requirements, any transmitter with a tag specifying Option Codes I5, I1, N1, I8, I7, or N7 requires an intrinsically safe analog meter (Part Nos. 01151-2614-0004 through 0009) or an LCD meter (Part Nos. 01151-1300-1000, 01151-1300-1001, 01151-1351-1000, or 01151-1351-1001).



**⚠ WARNING**

Failure to install flange adapter O-rings can cause process leaks, which can result in death or serious injury.

There are two styles of Rosemount flange adapters, each requiring a unique O-ring, as shown below. Each flange adapter is distinguished by its unique groove.



Use only the O-ring designed to seal with the corresponding flange adapter.

Refer to the Spare Parts List on page 5-19 for the part numbers of the flange adapters and O-rings designed for the Model 1151 Pressure Transmitter.

## GENERAL CONSIDERATIONS

The accuracy of a flow, pressure, or level measurement depends on proper installation of the transmitter and impulse piping. The piping between the process and transmitter must accurately transmit process pressure to the transmitter. Mount the transmitter close to the process and use a minimum of piping to achieve best accuracy. However, keep in mind the need for easy access, safety of personnel, practical field calibration, and a suitable transmitter environment.

In general, install the transmitter so as to minimize vibration, shock, and temperature fluctuations.

Installations in food, beverage, and pharmaceutical processes may require sanitary seals and fittings. Regulations may dictate special installation requirements to maintain sanitation and cleanability. See Product Data Sheet 00813-0100-4016 for more information about sanitary pressure instruments from Rosemount Inc.

### Access Requirements

When choosing an installation location and position, take into account the need for access to the transmitter.

### Process Flange Orientation

Orient the process flanges to enable process connections to be made. For safety reasons, orient the drain/vent valves so that process fluid is directed down and away from technicians when the valves are used. This can be accomplished by pointing the hole in the outside valve body downward and away.

## Housing Rotation

**⚠ CAUTION**

Do not rotate the transmitter housing more than 90 degrees without disconnecting the header board. Exceeding 90 degrees rotation will damage the internal sensor module wiring.

The electronics housing is designed to be rotated up to 90 degrees in order to provide field access to the two housing compartments. (If rotating the housing more than 90 degrees is necessary, follow the transmitter disassembly procedures in **Section 4 Troubleshooting**.) To rotate the housing up to 90 degrees, loosen the housing lock nut and turn the housing not more than 90 degrees from the orientation shown in Figure 3-2.

---

**NOTE**

Seal module threads with Loctite® 222 before retightening housing lock nut (see **Connecting the Electrical Housing to the Sensor** on page 4-6).

---

### Terminal Side of Electronics Housing

Mount the transmitter so that the terminal side of the housing is accessible by providing:

- A ¾-inch clearance for cover removal with no meter
- A 3-inch clearance for cover removal with a meter installed

If practical, provide approximately 6 inches clearance so that a meter may be installed later. The terminal side is marked on the nameplate located on the side of the transmitter.

### Circuit Side of Electronics Housing

The circuit compartment should not routinely need to be opened when the unit is in service. However, provide 6 inches clearance, if possible, to allow access to the integral zero and span buttons or for on-site maintenance. The circuit side of the housing is marked on the nameplate located on the side of the transmitter.

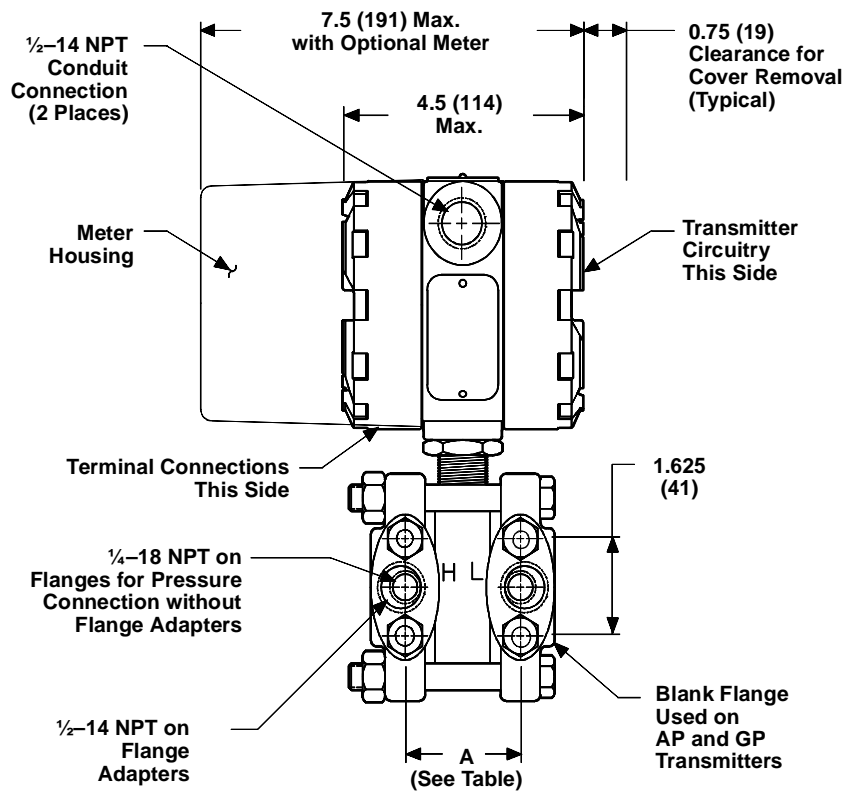
### Exterior of Electronics Housing

The Model 1151 Smart Pressure Transmitter uses the same housing as the analog Model 1151. For this reason, integral span and zero screws—non-functional on the Model 1151 Smart Pressure Transmitter—are located under the nameplate on the side of the transmitter.

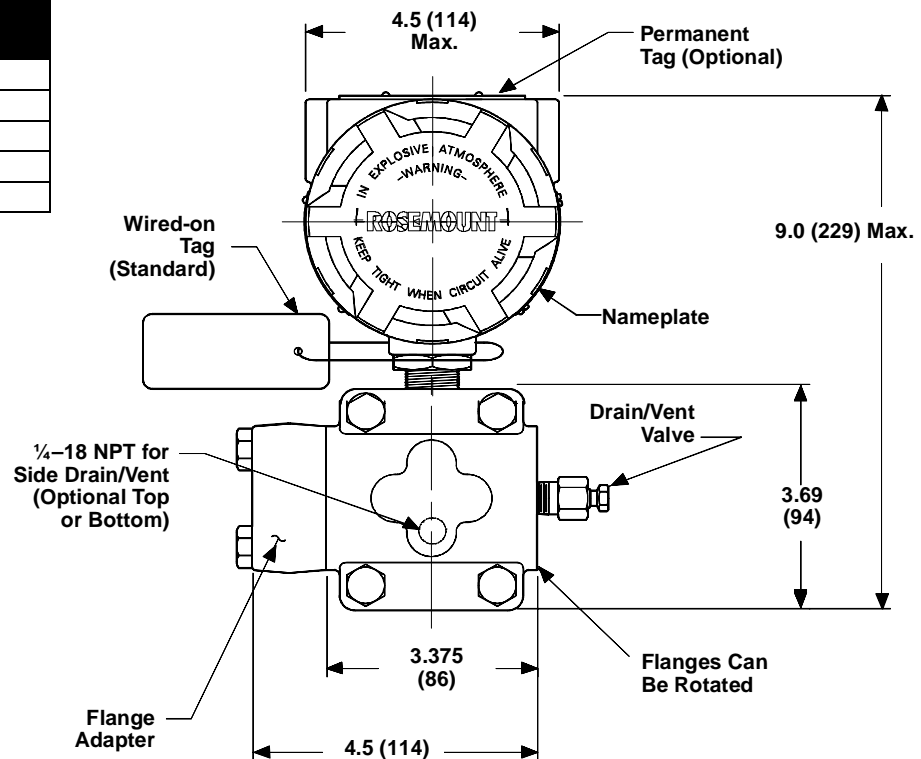
## MECHANICAL CONSIDERATIONS

Rosemount Model 1151 Transmitters may be panel-mounted, wall-mounted, or attached to a 2-inch pipe through an optional mounting bracket. Figures 3-2 and 3-3 show the transmitter dimensions.

FIGURE 3-2. Model 1151AP, DP, GP, and HP Dimensional Drawings.



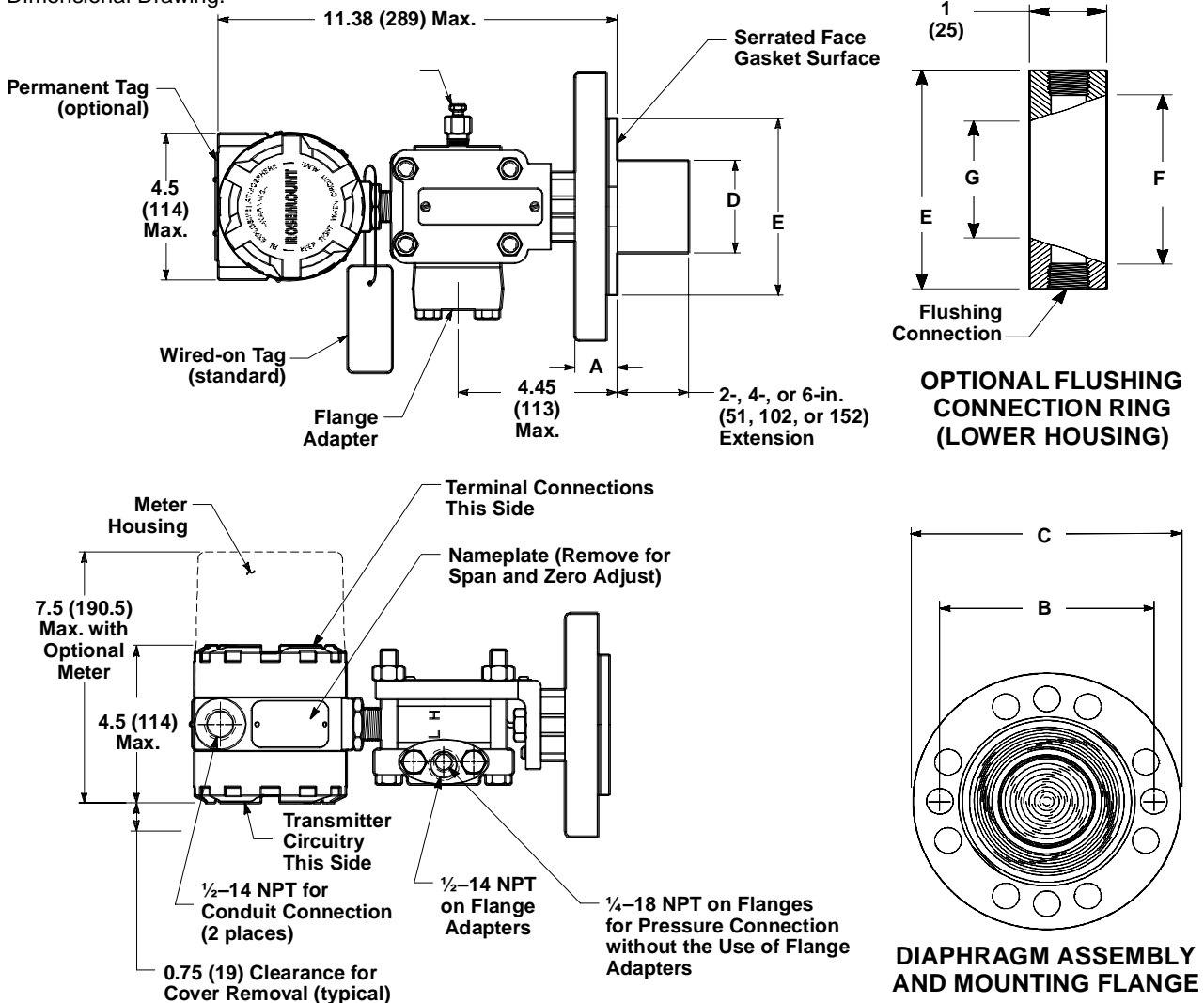
| Range   | Flange Distance "A" Center to Center |    |
|---------|--------------------------------------|----|
|         | inches                               | mm |
| 3, 4, 5 | 2.125                                | 54 |
| 6, 7    | 2.188                                | 56 |
| 8       | 2.250                                | 57 |
| 9       | 2.281                                | 58 |
| 0       | 2.328                                | 59 |



NOTE  
Dimensions are in inches (millimeters).

1151-1151A.B05A

FIGURE 3-3. Model 1151LT Dimensional Drawing.



**NOTE**  
Dimensions are in inches (millimeters).

TABLE 3-1. Model 1151LT Dimensional Specifications.

| Class        | Pipe Size | Flange Thickness<br>A | Bolt Circle Diameter<br>B | Outside Diameter<br>C | No. of Bolts | Bolt Hole Diameter | Exten. Diam. D (1) | O.D. Gask. Surf. E | Lower Housing |              |
|--------------|-----------|-----------------------|---------------------------|-----------------------|--------------|--------------------|--------------------|--------------------|---------------|--------------|
|              |           |                       |                           |                       |              |                    |                    |                    | Xmtr Side F   | Proc. Side G |
| ANSI 150     | 2 (51)    | 1.12 (28)             | 4.75 (121)                | 6.0 (152)             | 4            | 0.75 (19)          | NA                 | 3.75 (95)          | 2.9 (74)      | 2.16 (55)    |
|              | 3 (76)    | 1.31 (33)             | 6.0 (152)                 | 7.5 (190)             | 4            | 0.75 (19)          | 2.58 (65)          | 5.0 (127)          | 3.11 (79)     | 3.11 (79)    |
|              | 4 (102)   | 1.31 (33)             | 7.5 (190)                 | 9.0 (228)             | 8            | 0.75 (19)          | 3.5 (89)           | 6.81 (173)         | 4.06 (103)    | 4.06 (103)   |
| ANSI 300     | 2 (51)    | 1.25 (32)             | 5.0 (127)                 | 6.5 (165)             | 8            | 0.75 (19)          | NA                 | 3.75 (95)          | 2.9 (74)      | 2.16 (55)    |
|              | 3 (76)    | 1.50 (38)             | 6.62 (168)                | 8.25 (209)            | 8            | 0.88 (22)          | 2.58 (65)          | 5.0 (127)          | 3.11 (79)     | 3.11 (79)    |
|              | 4 (102)   | 1.62 (41)             | 7.88 (200)                | 10.0 (254)            | 8            | 0.88 (22)          | 3.5 (89)           | 6.81 (173)         | 4.06 (103)    | 4.06 (103)   |
| ANSI 600     | 2 (51)    | 1.12 (28)             | 5.0 (127)                 | 6.5 (165)             | 8            | 0.75 (19)          | NA                 | 3.75 (95)          | 2.9 (74)      | 2.16 (55)    |
|              | 3 (76)    | 1.37 (35)             | 6.62 (168)                | 6.62 (168)            | 8            | 0.88 (22)          | 2.58 (65)          | 5.0 (127)          | 3.11 (79)     | 3.11 (79)    |
| DIN PN10-40  | DN 50     | 26 mm                 | 125 mm                    | 165 mm                | 4            | 18 mm              | NA                 | 95 mm              | 74 mm         | 55 mm        |
| DIN PN 25/40 | DN 80     | 30 mm                 | 160 mm                    | 200 mm                | 8            | 18 mm              | 65 mm              | 127 mm             | 79 mm         | 79 mm        |
|              | DN 100    | 30 mm                 | 190 mm                    | 235 mm                | 8            | 22 mm              | 89 mm              | 173 mm             | 103 mm        | 103 mm       |
| DIN PN 10/16 | DN 100    | 26 mm                 | 180 mm                    | 220 mm                | 8            | 18 mm              | 89 mm              | 173 mm             | 103 mm        | 103 mm       |

(1) Tolerances are 0.040 (1.02), -0.020 (0.51).

1151-1151H25A, 1151G25C, 3031C27E, 3031B27A

## MOUNTING CONSIDERATIONS

The Model 1151 Smart Pressure Transmitter weighs 12 lb. (5.4 kg) without a meter and 15 lb. (6.8 kg) with a meter. This weight must be securely supported. The transmitter is calibrated in an upright position at the factory. If this orientation is changed during mounting, the zero point will shift by an amount equivalent to the liquid head caused by the mounting position. **Full Trim** on page 2-12 describes how to correct this shift.

### NOTE

Do not plug the low side with a solid plug. Plugging the low side will cause an output shift.

## Mounting Requirements (for Steam, Liquid, Gas)

### Taps

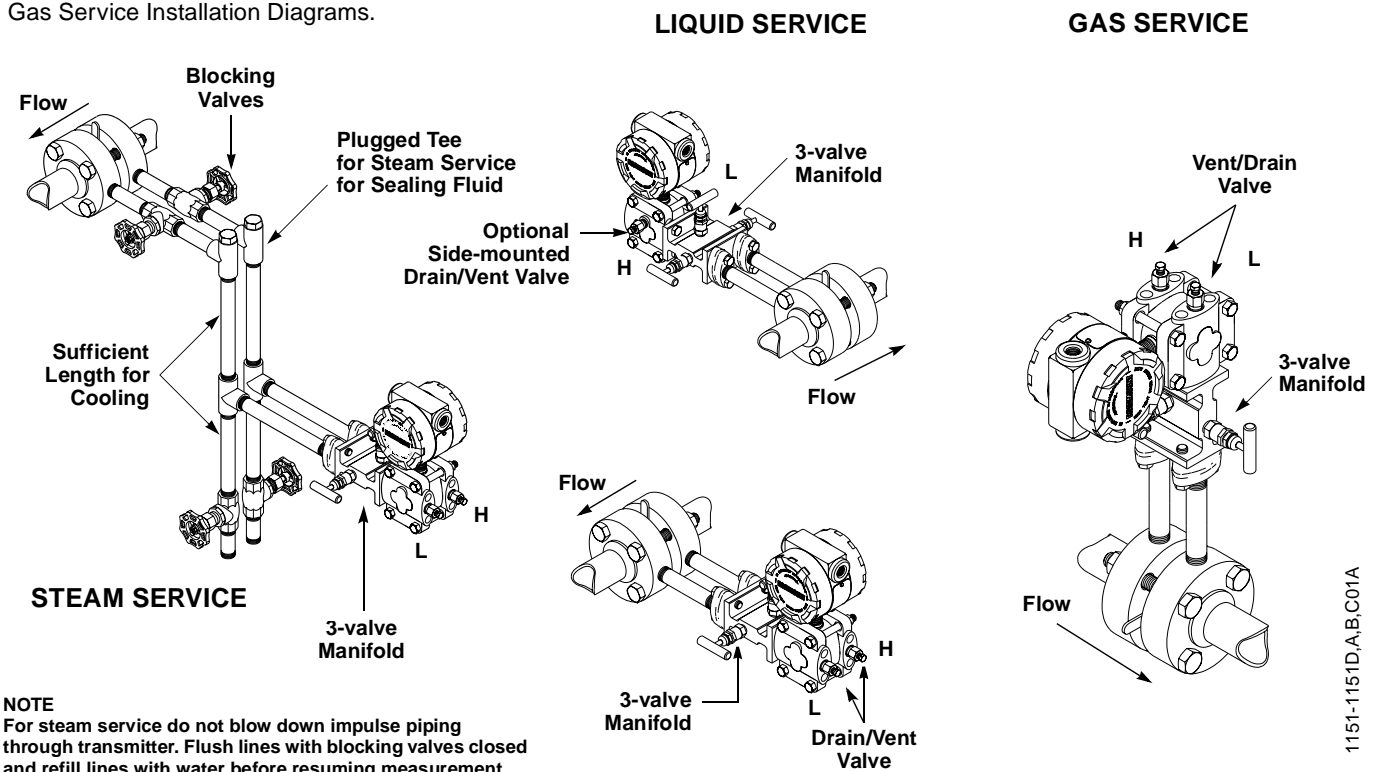
The following information applies to steam, liquid, and gas installations.

Tap placement location is dependent on the type of process being measured, and on whether the transmitter has side drain/vent valves:

- For liquid flow measurement, place taps to the side of the line to prevent sediment deposits, and mount the transmitter beside or below these taps so gases can vent into the process line and away from the transmitter.
- For gas flow measurement, place taps in the top or side of the line and mount the transmitter beside or above the taps so liquid will drain away from the transmitter.
- For steam flow measurement, place taps to the side of the line with the transmitter mounted below them to ensure that the impulse piping stays filled with condensate.
- For transmitters with side drain/vent valves, place taps to the side of the line. (See **Drain/Vent Valves** on page 3-8 for mounting position of drain/vent valves).

See Figure 3-4 for a diagram of these arrangements.

FIGURE 3-4. Steam, Liquid, and Gas Service Installation Diagrams.



**Drain/Vent Valves**

Drain/vent valve orientation is also dependent on the process being measured:

- For liquid service, mount the side drain/vent valve upward to allow the gases to vent.
- For gas service, mount the drain/vent valve down to allow any accumulated liquid to drain.

To change the drain/vent valve orientation from top to bottom, rotate the process flange 180 degrees.

**Impulse Piping**

The piping between the process and the transmitter must accurately transfer the pressure in order to obtain accurate measurements. In this pressure transfer, there are five possible sources of error:

- Leaks
- Friction loss (particularly if purging is used)
- Trapped gas in a liquid line
- Liquid in a gas line
- Temperature-induced or other density variation between the legs

The best location for the transmitter in relation to the process pipe depends on the process itself. Consider the following general guidelines in determining transmitter location and placement of impulse piping:

- Keep impulse piping as short as possible.
- Slope the impulse piping at least 1 inch per foot (8 centimeters per meter) upward from the transmitter toward the process connection for liquid.
- Slope the impulse piping at least 1 inch per foot (8 centimeters per meter) downward from the transmitter toward the process connection for gas.
- Avoid high points in liquid lines and low points in gas lines.
- Make sure both impulse legs are the same temperature.
- Use impulse piping large enough to avoid friction effects and prevent blockage.
- Vent all gas from liquid piping legs.
- For steam service, fill impulse piping with water to prevent contact of live steam with the transmitter.

**⚠ CAUTION**

Steam or other elevated temperature processes can cause damage to the sensor. Do not allow the temperature inside the process flanges to exceed the transmitter limit of 220 °F (104 °C).

- When using a sealing fluid, fill both piping legs to the same level.
- When purging is necessary, make the purge connection close to the process taps and purge through equal lengths of the same size pipe. Avoid purging through the transmitter.
- Keep corrosive or hot process material out of direct contact with the sensor module and flanges.
- Prevent sediment deposits in the impulse piping.
- Keep the liquid head balanced on both legs of the impulse piping.

## Process Connections

### Flange Adaptors:

Model 1151AP, DP, GP, and HP process connections on the transmitter flanges are ¼–18 NPT. Flange adapters are supplied with standard ½–14 NPT Class 2 connections. The flange adapters allow users to disconnect from the process by removing the flange adapter bolts. Use plant-approved lubricant or sealant when making the process connections. Figure 3-2 shows the distance between pressure connections. This distance may be varied  $\pm 1/8$  in. (3.2 mm) by rotating one or both of the flange adapters.

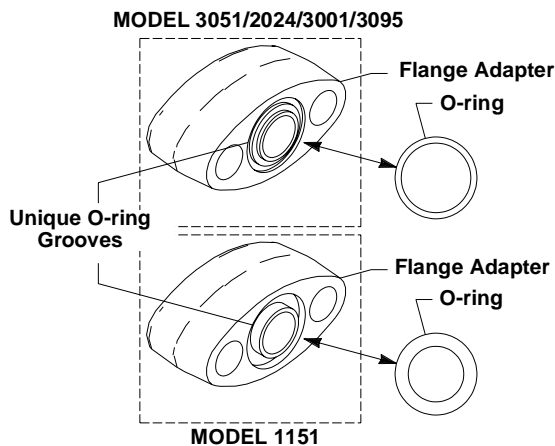
On open vessels, the low-side process flange is open to atmosphere and should be mounted with the threaded hole pointed down. On closed vessels, this connection is used for the dry or wet leg.


High-pressure-side process connections for the Model 1151LT Transmitter are offered with 2-, 3-, or 4-in., Class 150, 300, or 600 flanges; DN 50 (PN 10/40), DN 80 (PN 25/40), or DN 100 (PN 10/16, 25/40). Low-pressure-side process connections for the Model 1151LT Transmitter are offered with ¼–18 NPT on the flange, and ½–14 NPT on the adapter.

### O-rings:

The two styles of Rosemount flange adapters (Model 1151 and Model 3051/2024/3001/3095) each require a unique O-ring (see Figure 3-5). Use only the O-ring designed for the corresponding flange adaptor.

FIGURE 3-5. O-Rings.



 When compressed, Teflon<sup>®</sup> O-rings tend to “cold flow,” which aids in their sealing capabilities.

### NOTE

Teflon<sup>®</sup> O-rings should be replaced if the flange adapter is removed.

### Tightening the Seal:

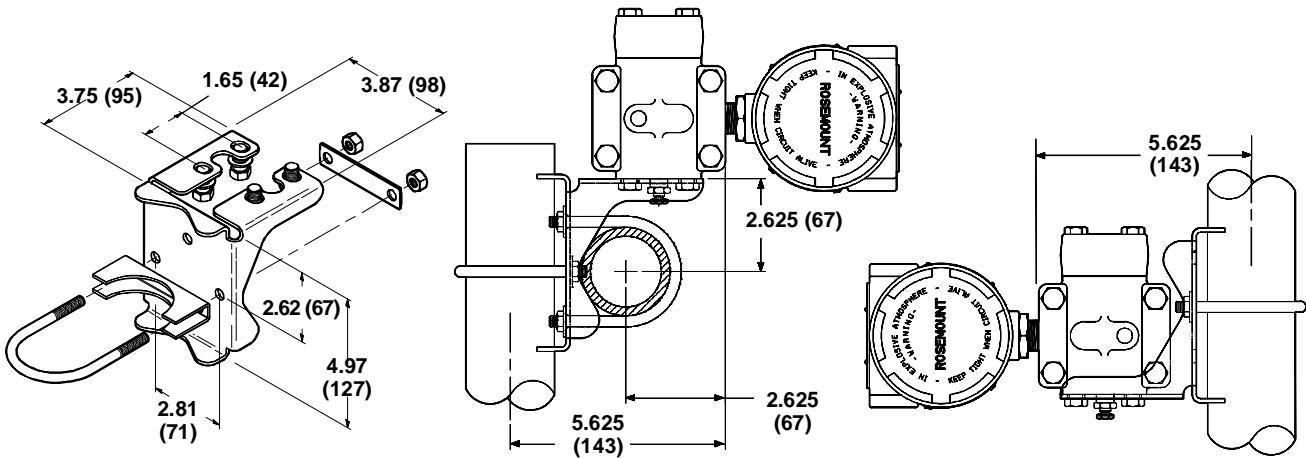
To ensure a tight seal on the flange adapters or a three-valve manifold, first finger-tighten both bolts, then wrench-tighten the first bolt to approximately 29 ft-lbs (39 N-m). Wrench-tighten the second bolt to approximately 29 ft-lbs (39 N-m).



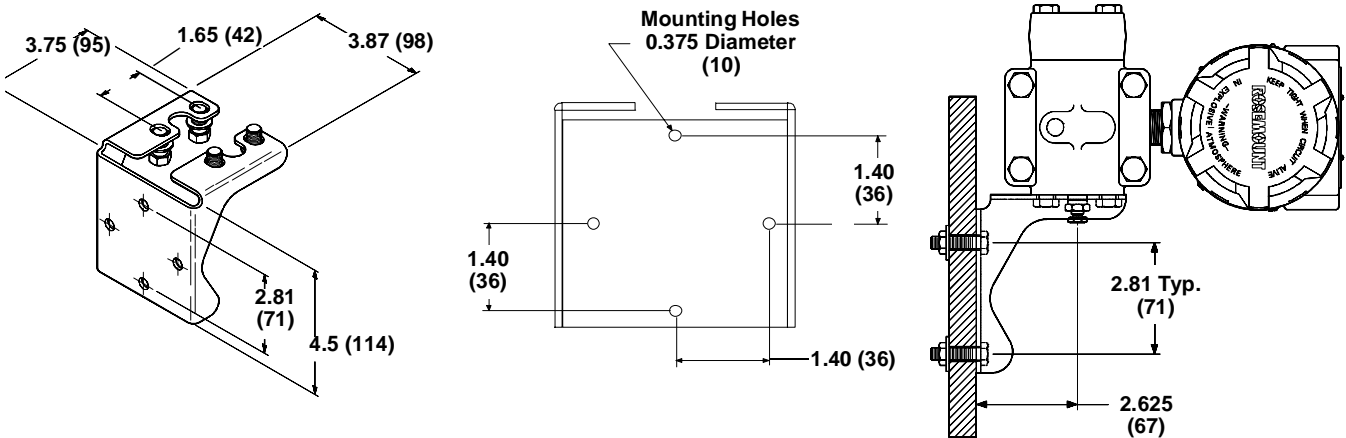
**Mounting Brackets**

Optional mounting brackets permit mounting the transmitter to a wall, a panel, or a 2-inch horizontal or vertical pipe. Figure 3-6 illustrates some typical configurations this mounting brackets.

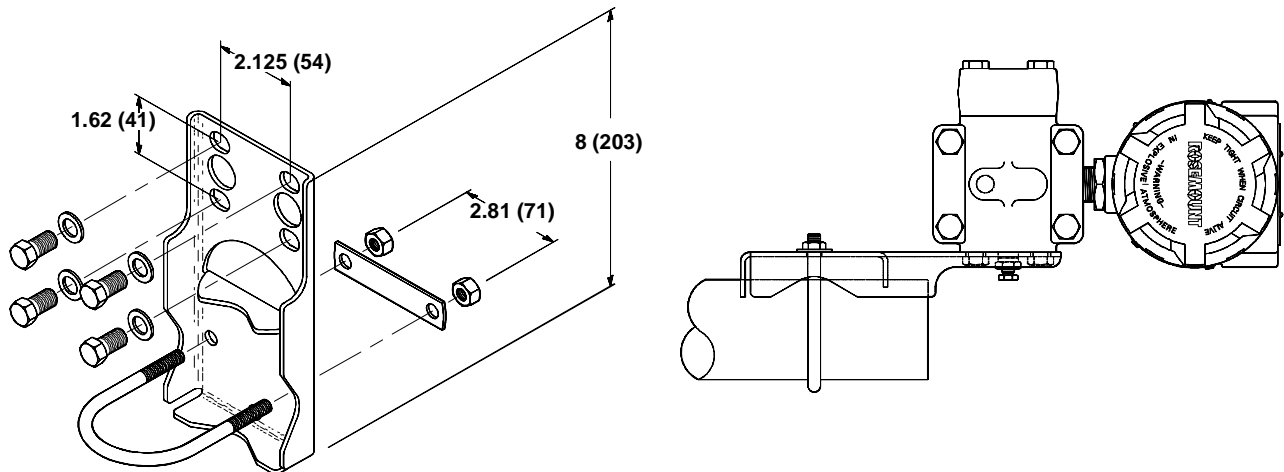
FIGURE 3-6. Mounting Bracket Options.



**MOUNTING BRACKET OPTION CODES B1, B4, AND B7.**



**PANEL MOUNTING BRACKET OPTION CODES B2 AND B5**



**FLAT MOUNTING BRACKET OPTION CODES B3, B6, AND B9**

**NOTE**  
Dimensions are in inches (millimeters).

3051-3051B19A, 1151-1151B, A06A

3051-3051D19A, 1151-0244A, -1151E06A

1151-1151F06B



## ELECTRICAL CONSIDERATIONS

### NOTE

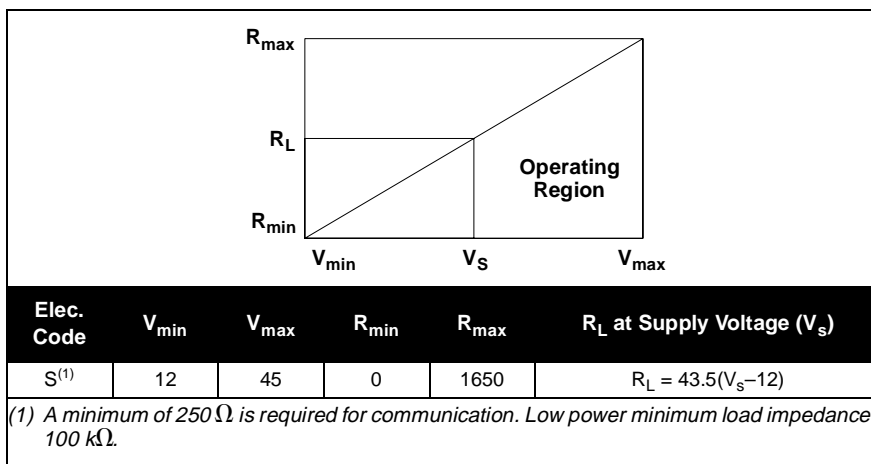
Make sure all electrical installation is in accordance with national and local code requirements.

### Power Supply

The dc power supply should provide power with less than 2% ripple. The total resistance load is the sum of the resistance of the signal leads and the load resistance of the controller, indicator, and related pieces. The resistance of intrinsic safety barriers, if used, must be included.

To use the Rosemount Model 282 Loop Validator to power the loop, connect the Model 282 Validator leads at the set of terminal screws labeled "Signal." Figure 3-7 illustrates power supply load limitations for the transmitter.

FIGURE 3-7. Power Supply Load Limitations.



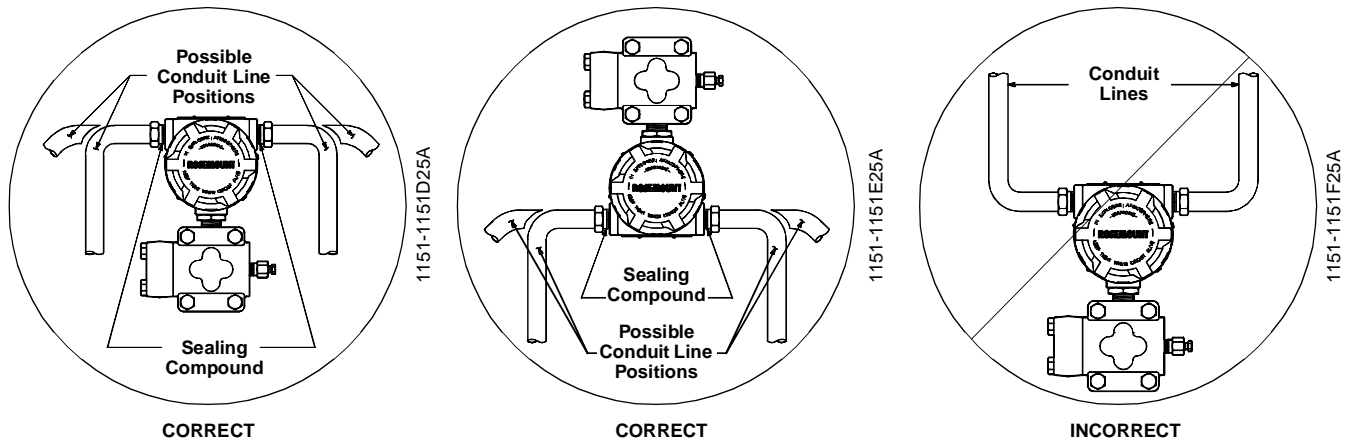
## Conduit Installation

**⚠ CAUTION**

If all connections are not sealed, excess moisture accumulation can damage the transmitter. Make sure to mount the transmitter with the electrical housing positioned downward for drainage. To avoid moisture accumulation in the housing, install wiring with a drip loop, and ensure the bottom of the drip loop is mounted lower than the conduit connections or the transmitter housing.

Recommended conduit connections are shown in Figure 3-8.

FIGURE 3-8. Conduit Installation Diagrams.



## Wiring

**⚠ CAUTION**


Do not connect the power signal wiring to the test terminals. Voltage may burn out the reverse-polarity protection diode in the test connection. If the test diode is destroyed, then the transmitter can still be operated without local indication by jumping the test terminals.

High voltage (greater than 50 V and greater than 0.005 amperes) can cause damage to the transmitter. Do not apply high voltage to the test terminals.

The signal terminals and test terminals are located in a compartment of the electronics housing that is separate from the transmitter electronics. The nameplate on the side of the transmitter indicates the locations of both of these compartments. The upper pair of terminals are the signal terminals and the lower pair are the test terminals. The test terminals have the same 4–20 mA output as the signal terminals and are only for use with the optional integral meter or for testing.

**NOTE**

An alternate location to connect an ammeter is on the set of terminals labelled “TEST.” Connect the positive lead of the ammeter to the positive test terminal, and the negative lead of the ammeter to the negative test terminal.

 To make connections, remove the cover on the side marked “Terminal” on the nameplate. All power to the transmitter is supplied over the signal wiring. Connect the lead that originates at the positive side of the power supply to the terminal marked “+” and the lead that originates at the negative side of the power supply to the terminal marked “-” as shown in Figure 3-9. No additional wiring is required.

Do not run signal wiring in conduit or open trays with power wiring or near heavy electrical equipment.

For improved performance against EMI/RFI effects, refer to page 3-19 for information on transient protection terminal blocks.

Shielded cable should be used for best results in electrically noisy environments.


**NOTE**

When conduit lines are used, signal wiring need not be shielded, but twisted pairs should be used for best results. Wiring must be 24 AWG or larger and not exceed 5,000 feet (1500 meters).

**NOTE**

A minimum loop resistance of 250  $\Omega$  is required to communicate with a hand-held HART-based communicator. With 250  $\Omega$  of loop resistance, the transmitter requires a minimum of 17 volts to output 20 mA. If a single power supply is used to power more than one Model 1151 Smart transmitter, the power supply used, and circuitry common to the transmitters, should not have more than 20  $\Omega$  of impedance at 1200 Hz.

**Grounding**


 Use the following techniques to properly ground the transmitter signal wiring and case:

**Signal Wiring**

Signal wiring may be grounded at any one point on the signal loop or may be left ungrounded. The negative terminal of the power supply is a recommended grounding point.

**Transmitter Case**

The transmitter case must be grounded in accordance with national and local electrical codes. The most effective transmitter case grounding method is a direct internal connection to earth ground with minimal impedance. The transmitter case may also be grounded through the process or conduit connections.

**Internal Ground Connection:** Inside the field terminals side of the electronics housing is the internal ground connection screw. This screw is identified by a ground symbol: .

**NOTE**

Grounding the transmitter case via threaded conduit connection may not provide sufficient ground continuity.



**NOTE**

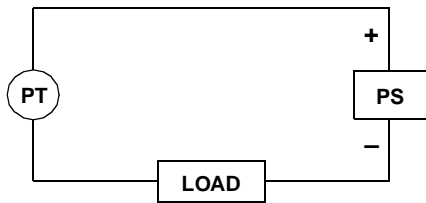
The transient protection terminal block (page 3-19) does not provide transient protection unless the transmitter case is properly grounded. Use the preceding guidelines to ground the transmitter case. Do not run the transient protection ground wire with signal wiring as the ground wire may carry excessive current if a lightning strike occurs.

**Grounding Effects**

The capacitance sensing module requires alternating current to generate a capacitance signal. This alternating current is developed in an oscillator circuit with a frequency of approximately 32 kHz. This signal is capacitor-coupled to transmitter-case ground through the sensing module. Because of this coupling, a voltage may be imposed across the load, depending on the choice of grounding. See Figure 3-9.

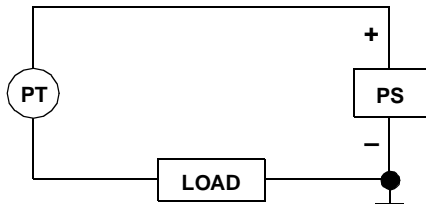
Impressed voltage, which is seen as high frequency noise, will have no effect on most instruments. Computers with short sampling times in circuits will detect a significant noise signal, which should be filtered out by using a large capacitor (1  $\mu$ F) or by using a 32 kHz LC filter across the load. Computers that are wired and grounded, as shown in Figure 3-9, are negligibly affected by this noise and do not need filtering.

FIGURE 3-9. Effects of Grounding on Accuracy for Fast Sample Computers.



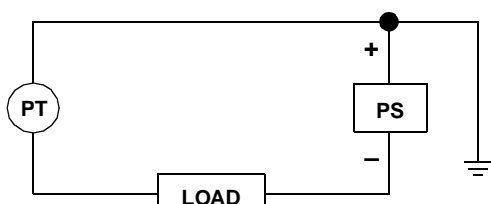
**Ungrounded System**

Impressed Voltage: 12 to 22 mV<sub>p-p</sub>  
32 kHz  
Effect: 0.01% of span, max.



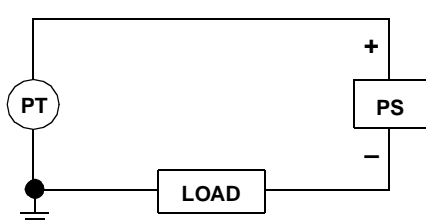
**Ground Between Negative Side of Power Supply and Load**

Impressed Voltage: 35 to 60 mV<sub>p-p</sub>  
32 kHz  
Effect: 0.03% of span, max.



**Ground Between Positive Side of Transmitter and Power Supply**

Impressed Voltage: 35 to 60 mV<sub>p-p</sub>  
32 kHz  
Effect: 0.03% of span, max.




**Ground Between Negative Terminal of Transmitter and Load**

Impressed Voltage: 500 to 600 mV<sub>p-p</sub>  
32 kHz  
Effect: 0.27% of span, max.

\*The effect caused by the impressed voltage on a computer with a sampling time of 100 microseconds using a 2 to 10 volt signal.

## Hazardous Locations Certifications

 The Model 1151 was designed with an explosion-proof housing and circuitry suitable for intrinsically safe and nonincendive operation. Factory Mutual explosion-proof certification is standard for the Model 1151 Smart Transmitter. Individual transmitters are clearly marked with a tag indicating the approvals they carry. Transmitters must be installed in accordance with all applicable codes and standards to maintain these certified ratings. Refer to **Hazardous Locations Certifications** on page 5-2 for information on these approvals.

## Environmental Requirements

Mount the transmitter in an environment that has minimal ambient temperature change. The transmitter electronics temperature operating limits are  $-40$  to  $185$  °F ( $-40$  to  $85$  °C). **Section 5 Specifications and Reference Data** lists the sensing element operating limits. Mount the transmitter so that it is not susceptible to vibration and mechanical shock and does not have external contact with corrosive materials.

## INSTALLATION OPTIONS

### Mounting Brackets

#### (OPTION CODES B1–B7 AND B9)

Optional mounting brackets available with the Model 1151 allow mounting to a 2-inch pipe or panel. Figure 3-6 shows bracket dimensions and mounting configurations for the various bracket options.


#### Pipe Mounting Brackets

Option Codes B1, B4, and B7 are sturdy, polyurethane-painted brackets designed for 2-inch pipe mounting. Option Code B1 is constructed of carbon steel with carbon steel bolts. Option Code B4 is the same bracket as Option Code B1, with 316 SST bolts. Option Code B7 is also the same bracket as Option Code B1 with a 316 SST bracket and 316 SST bolts.

#### Panel Mounting Brackets

Option Codes B3, B6, and B9 are flat brackets designed for 2-inch pipe mounting. Option Code B3 is constructed of carbon steel with a carbon steel U-bolt. Option Codes B6 and B9 are the same bracket configuration as Option Code B3. Option Code B6 provides 316 SST bolts and Option Code B9 provides a 316 SST bracket and 316 SST bolts.

### Analog Meters

 Option Codes M1–M3 and M6 provide local indication of the transmitter output in a variety of scaling configurations with an indicator accuracy of  $\pm 2$  percent. The plug-in mounting configuration allows for simple installation and removal of the analog meters. The meter scaling options are shown below.

|    |   |
|----|---|
| M1 | Linear analog meter, 0–100% scale             |
| M2 | Square-root analog meter, 0–100% flow scale   |
| M3 | Special scaling analog meter, (specify range) |
| M6 | Square-root analog meter, 0–100% flow scale   |



## LCD Meters

The LCD meter Option Codes, M4 and M7–M9, provide a highly accurate local display of the process variable. A variety of scaling configurations are available and listed as follows:

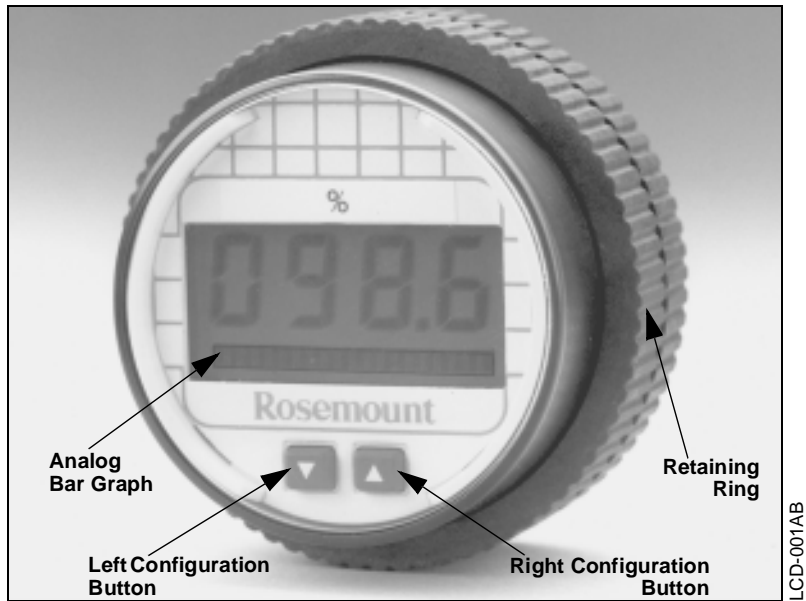
- M4 Linear LCD meter, 0 to 100%
- M7 Special scale LCD meter (specify range, mode, and engineering units)
- M8 Square-root LCD meter, 0 to 100%
- M9 Square-root LCD meter, 0 to 10%

## LCD Meter Configuration

The Rosemount LCD meter plugs directly into the Model 1151 Smart Pressure Transmitter to provide a highly accurate digital display of the process variable. This manual explains the configuration and assembly of the LCD meter and includes the applicable functional, performance, and physical specifications. This meter adds no voltage drop in the 4–20 mA current loop when connected directly across the transmitter test terminals.

The LCD meter may be configured to meet specific requirements by using the left and right calibration buttons located on the meter face as shown in Figure 3-10. The analog bar graph is also shown in Figure 3-10. The 20-segment bar graph is factory calibrated and represents 4–20 mA directly.

FIGURE 3-10. LCD Meter.



No calibration equipment is required to configure the LCD meter, but between 4 and 20 mA must be flowing through the loop. The actual value of the current is not significant. In addition, meter configuration does not affect the transmitter/loop current. Use the following meter configuration procedure to properly configure the LCD meter:

### Remove the Cover

1. Unscrew the retaining ring shown in Figure 3-10 and lift the transparent cover off of the housing.

### NOTE

The LCD meter time-out is approximately 16 seconds. If keys are not pressed within this period, the indicator reverts to reading the current signal.

**Position the Decimal Point and Select the Meter Function**

2. Press the left and right configuration buttons simultaneously and release them immediately.
3. To move the decimal point to the desired location, press the left configuration button.
4. To scroll through the mode options, press the right configuration button repeatedly until the desired mode is displayed. See Table 3-2.

TABLE 3-2. LCD Meter Modes.

| Options  | Relationship between Input Signal and Digital Display |
|--|---|
| L in   | Linear  |
| L inF  | Linear with five-second filter                        |
| Srt  | Square root   |
| SrtF   | Square root with five-second filter                   |
| <p><b>Square root function</b> only relates to the digital display. The bar graph output remains linear with the current signal.</p> <p><b>Square root response</b><br/>The digital display will be proportional to the square root of the input current where 4 mA=0 and 20 mA=1.0, scaled per the calibration procedure. The transition point from linear to square root is at 25% of full scale flow.</p> <p><b>Filter response</b> operates upon "present input" and "input received in the previous five second interval" in the following manner:<br/> <math display="block">\text{Display} = (0.75 \times \text{previous input}) + (0.25 \times \text{present input})</math>                     This relationship is maintained provided that the previous reading minus the present reading is less than 25% of full scale.</p> |   |

**Store the Information**

5. Press both configuration buttons simultaneously for two seconds. The meter displays "----" for approximately 7.5 seconds while the information is being stored.

**Set the Display Equivalent to a 4 mA Signal**

6. Press the left button for two seconds.
7. To set the display numbers to a lower value, press the left configuration button, and to set the display numbers to a higher value, press the right configuration button. Set the numbers between -999 and 1000.
8. To store the information, press both configuration buttons simultaneously for two seconds.

**Set the Display Equivalent to a 20 mA Signal**

9. Press the right button for two seconds.
10. To set the display numbers to a lower value, press the left configuration button, and to set the display numbers to a higher value, press the right configuration button. Set the numbers between -999 and 9999. The sum of the 4 mA point and the span must not exceed 9999.
11. To store the information, press both configuration buttons simultaneously for two seconds. The LCD meter is now configured.

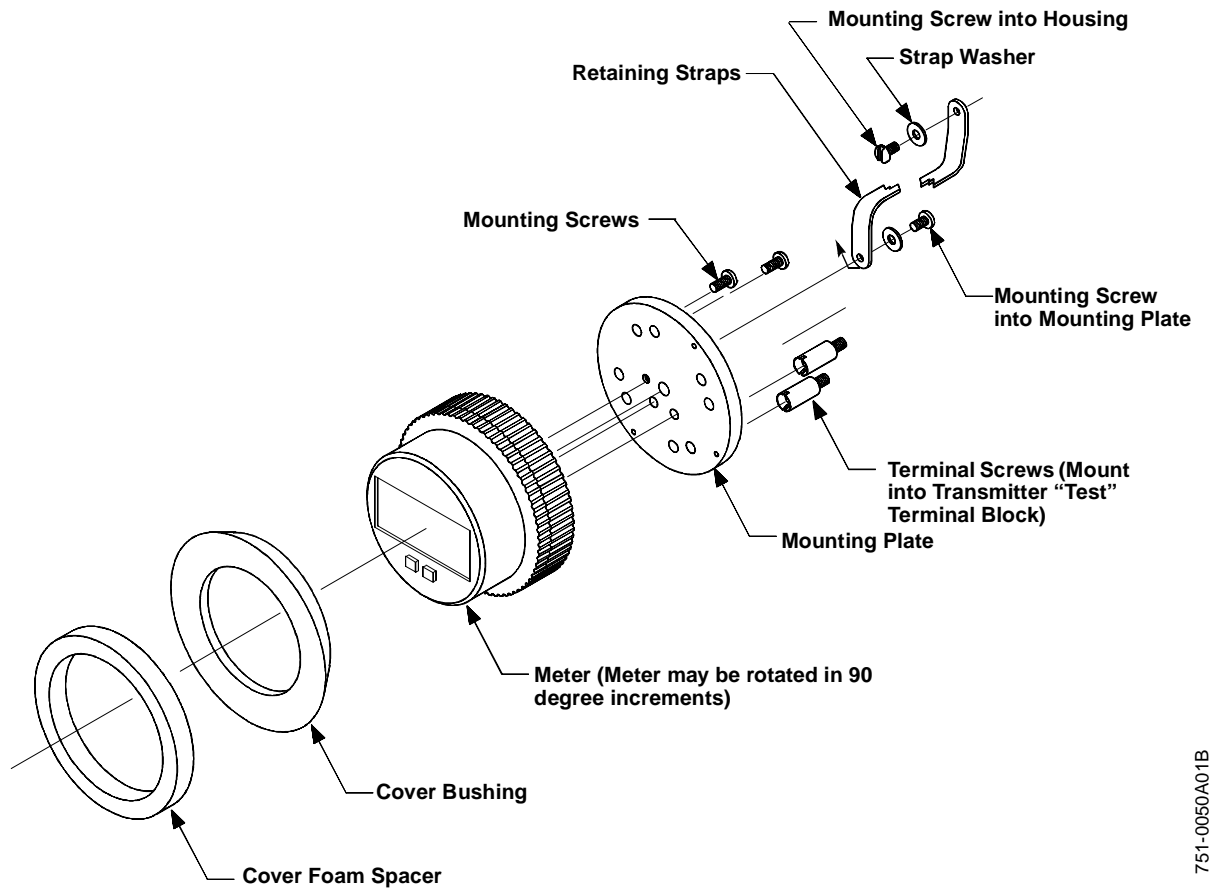
**Replace the Cover**

12. Make sure the rubber gasket is seated properly, replace the transparent cover, and replace the retaining ring.

**LCD Meter Assembly**

Figure 3-11 shows the mounting hardware required to properly install the LCD meter on a transmitter or in the field signal indicator. This mounting hardware may also be used with the Rosemount universal (analog) meter.

FIGURE 3-11. LCD Meter  
Exploded View.



751-0050A01B



## Terminal Blocks

The terminal block options can increase the Model 1151 Pressure Transmitter's ability to withstand electrical transients induced by lightning, welding, heavy electrical equipment, or switch gears. The Model 1151 Pressure Transmitter, with the integral transient protection option, meets the standard performance specifications as outlined in this product manual. In addition, the transient protection circuitry meets IEEE Std 587, Category B, and IEEE Std 472, Surge Withstand Capability.

FIGURE 3-12. Transient Protection and Filter Terminal Block (Code R1).





1151-032AB

### Transient Protection and Filter Terminal Block (Option Code R1)

#### Terminal Block Installation

Option Code R1 provides EMI/RFI protection and the benefit of integral transient protection. This terminal block can be ordered as a spare part to retrofit existing Model 1151 Transmitters with Option Code R2.

Use a phillips and a flat-blade screwdriver and the following steps to install a retrofitable transient protection terminal block:

1. Turn off all power to the Model 1151 on which the terminal block is being installed.
2.  Unscrew the transmitter terminal-side (indicated on the housing nameplate) cover (on the high side of the transmitter) exposing the standard terminal block.
3. Disconnect wiring to the terminal block.
4. Remove the single grounding screw and the two signal terminal screws, with terminal eyelet washers, from the standard terminal block.
5. Set the retrofitable transient protection terminal block into the housing, making sure the ground and signal terminals are properly aligned.
6. Insert the short mounting screws with washers in the mounting holes and tighten the terminal block to the transmitter.
7. Turn the transient protector grounding sleeve, located in the grounding hole, just enough to stabilize the unit on the transmitter. Overtightening the grounding sleeve will shift the terminal block out of alignment.
8. Insert the long grounding screw with the square washer into the grounding hole and tighten.
9. Connect the positive power supply wire to the transient protector terminal screw labeled "+ SIGNAL", and the negative power supply wire to the terminal screw labeled "- SIGNAL."
10. Attach the supplied label to the terminal side transmitter cover.
11.  Replace the terminal side cover on the transmitter.



See "Safety Messages" on page 3-2 for complete warning information.



# Troubleshooting

## OVERVIEW

Table 4-1 provides summarized troubleshooting suggestions for the most common operating problems.

If you suspect a malfunction despite the absence of any diagnostic messages on the communicator display, follow the procedures described here to verify that transmitter hardware and process connections are in good working order. Always deal with the most likely and easiest-to-check conditions first.

## SAFETY MESSAGES

### Warnings (⚠)

Procedures and instructions in this section that raise potential safety issues are indicated by a warning symbol (⚠). Refer to the following warning messages before performing an operation preceded by this symbol.

#### ⚠ WARNING

- Isolate a failed transmitter from its pressure source as soon as possible. Pressure that may be present could cause death or serious injury to personnel if the transmitter is disassembled or ruptures under pressure.
- Explosions can cause death or serious injury. Do not remove the instrument cover in explosive atmospheres when the circuit is alive.
- Explosions can cause death or serious injury. Do not break the housing seal in explosive environments. Breaking the housing seal invalidates the explosion-proof housing rating.
- Process leaks can cause death or serious injury. An incorrectly installed backup ring can destroy the o-ring and cause process leaks. Install the backup ring using the following procedure.
- Exposure to hazardous substances can cause death or serious injury. If a hazardous substance is identified, a Material Safety Data Sheet (MSDS), required by law to be available to people exposed to specific hazardous substances, must be included with the returned goods.
- Explosions can cause death or serious injury. Do not disassemble the glass in the meter cover in explosive atmospheres. Disassembling the glass in the meter cover invalidates the explosion-proof meter rating.

**⚠ WARNING**

- The following performance limitations may inhibit efficient or safe operation. Critical applications should have appropriate diagnostic and backup systems in place. Pressure transmitters contain an internal fill fluid. It is used to transmit the process pressure through the isolating diaphragms to the pressure sensing element. In rare cases, oil leak paths in oil-filled pressure transmitters can be created. Possible causes include physical damage to the isolator diaphragms, process fluid freezing, isolator corrosion due to an incompatible process fluid, etc. A transmitter with an oil fill fluid leak can continue to perform normally for a period of time. Sustained oil loss will eventually cause one or more of the operating parameters to exceed published specifications while a small drift in operating point output continues. Symptoms of advanced oil loss and other unrelated problems include:
  - Sustained drift rate in true zero and span or operating point output or both
  - Sluggish response to increasing or decreasing pressure or both
  - Limited output rate or very nonlinear output or both
  - Change in output process noise
  - Noticeable drift in operating point output
  - Abrupt increase in drift rate of true zero or span or both
  - Unstable output
  - Output saturated high or low

TABLE 4-1. Troubleshooting Symptoms and Corrective Action.

| Symptom   | Potential Source        | Corrective Action  |
|---|-------------------------|--|
| Transmitter does not communicate with the Model 275 | Loop Wiring             | Check for a minimum of 250 Ω resistance between the power supply and the communicator connection.<br>Check for adequate voltage to the transmitter. (If the communicator is connected and 250 Ω resistance is properly in the loop, then the loop requires a minimum of 17 volts to operate.)<br>Check for intermittent shorts, open circuits, and multiple grounds.<br>Specify the transmitter by tag number. See the display sequence below. |
|   | I.S. Barrier            | Refer to appropriate I.S. Barrier documentation.   |
| High Output   | Primary Element         | Check for restrictions at primary element.   |
|   | Impulse Piping          | Check for leaks or blockage.<br>Ensure that blocking valves are fully open.<br>Check for entrapped gas in liquid lines and for liquid in dry lines.<br>Ensure that the density of fluid in impulse lines is unchanged.<br>Check for sediment in transmitter process flanges.   |
|   | Power Supply            | Check the power supply output voltage at the transmitter. It should be 12 to 45 V dc.  |
|   | Transmitter Electronics | Connect the Model 268 and enter the XMTR TEST mode to determine any electronic failures.<br>Make sure that post connectors are clean.<br>If the electronics are still suspect, substitute new electronics.   |
|   | Sensing Element         | The sensing element is not field repairable and must be replaced if found to be defective. See "Disassembly procedure" later in this section for instructions on disassembly. Check for obvious defects, such as a punctured isolating diaphragm or fill fluid loss, and contact the Rosemount National Response Center at 1-800-THE-RSMT (1-800-654-7768).  |

TABLE 4-1. (continued).

| Symptom                                    | Potential Source           | Corrective Action   |
|--|----------------------------|---|
| Erratic Output                             | Loop Wiring                | <p>Check for adequate voltage to the transmitter. It should be 12 to 45 V dc with no load. Check for intermittent shorts, open circuits and multiple grounds.</p> <div style="border: 1px solid black; padding: 5px; text-align: center;"> <p><b>⚠ CAUTION</b></p> <p>Do not use over 45 volts to check the loop, or damage to the transmitter electronics may result.</p> </div> <p>Connect the Model 275 and enter the LOOP TEST mode to generate signals of 4 mA, 20 mA, and user-selected values.</p>   |
|  | Process Pulsation          | Adjust the electronic damping with the Model 275.   |
|  | Transmitter Electronics    | <p>Connect the communicator and perform a transmitter test to determine any electronic failures. Make sure the post connectors are clean. If the electronics are still suspect, substitute new electronics.</p>   |
|  | Impulse Piping             | Check for entrapped gas in liquid lines and for liquid in dry lines.  |
| Low Output or No Output                    | Primary Element            | <p>Check the insulation and condition of primary element. Note any changes in process fluid properties that may affect output.</p>  |
|  | Loop Wiring                | <p>Check for adequate voltage to the transmitter. It should be 12 to 45 V dc. Check the milliamp rating of the power supply against the total current being drawn for all transmitters being powered. Check for shorts and multiple grounds. Check for proper polarity at the signal terminal. Check loop impedance. Check whether the transmitter is in multidrop mode, thus locking the output at 4 mA. Connect the communicator and perform a loop test.</p> <div style="border: 1px solid black; padding: 5px; text-align: center;"> <p><b>⚠ CAUTION</b></p> <p>Do not use over 45 volts to check the loop, or damage to the transmitter electronics may result.</p> </div> <p>Check wire insulation to detect possible shorts to ground.</p> |
|  | Impulse Piping             | <p>Ensure that the pressure connection is correct. Check for leaks or blockage. Check for entrapped gas in liquid lines. Check for sediment in the transmitter process flange. Ensure that blocking valves are fully open and that bypass valves are tightly closed. Ensure that density of the fluid in the impulse piping is unchanged.</p>   |
|  | Transmitter Electronics    | <p>Connect the communicator and check the sensor limits to ensure calibration adjustments are within the sensor range. Connect the communicator and perform a transmitter test to determine electronics failure. Make sure the post connectors are clean. If the electronics are still suspect, substitute new electronics.</p>   |
|  | Sensing Element            | <p>The sensing element is not field repairable and must be replaced if found to be defective. See "Disassembly procedure" later in this section for instructions on disassembly. Check for obvious defects, such as punctured isolating diaphragm or fill fluid loss, and contact Rosemount National Response Center at 1-800-THE-RSMT(1-800-654-7768).</p>   |
| Transmitter Does Not Characterize Properly | Pressure Source/Correction | <p>Check for restrictions or leaks. Check for proper leveling or zeroing of the pressure source. Check weights/gauge to ensure proper pressure setting. Determine if the pressure source has sufficient accuracy. (The pressure source should be at least three times more accurate than the Model 1151 Smart.)</p>   |

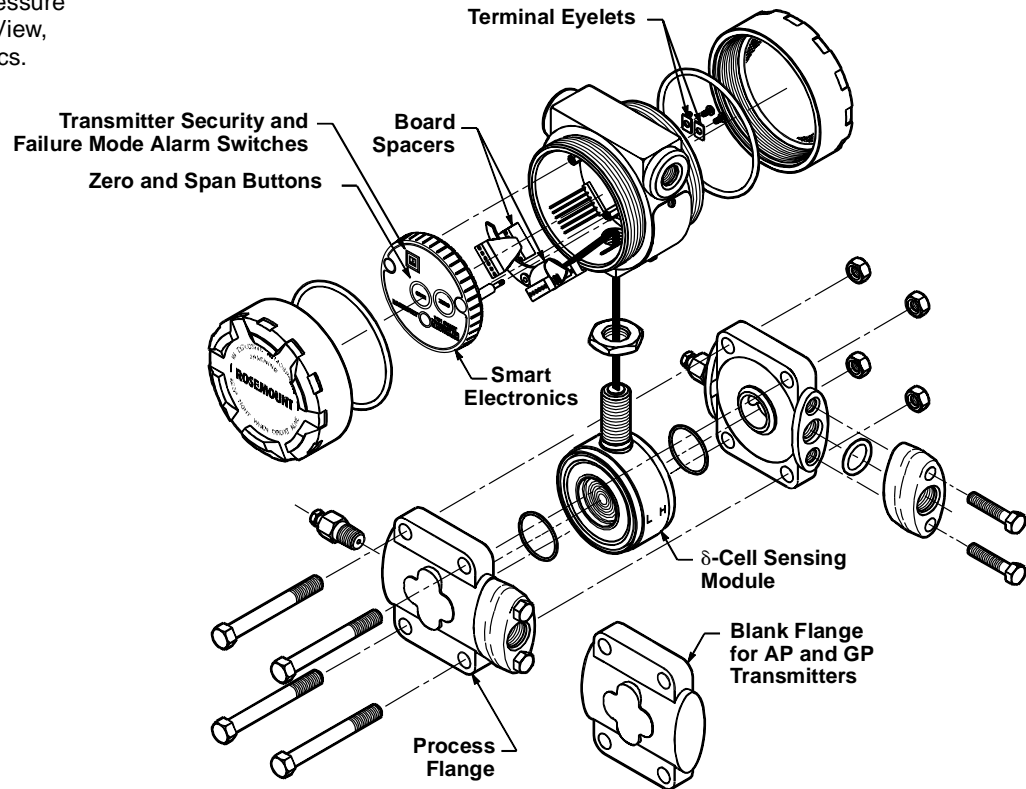
TABLE 4-1. (continued).

| Symptom                                    | Potential Source        | Corrective Action  |
|--|-------------------------|--|
| Transmitter Does Not Characterize Properly | mA Meter                | Determine if the mA meter is functioning properly.   |
|  | Power Supply            | Check the power supply output voltage at transmitter. It should be 12 to 45 V dc with no load. Check for a minimum of 250 $\Omega$ resistance between the Model 268 and the power supply.  |
|  | Transmitter Electronics | Connect the communicator and perform a transmitter test to determine any electronic failures. Make sure the post connectors are clean. If electronics are still suspect, substitute with new electronics.  |
|  | Sensing Element         | The sensing element is not field repairable and must be replaced if found to be defective. See "Disassembly procedure" later in this section for instructions on disassembly. Check for obvious defects, such as punctured isolating diaphragm or fill fluid loss, and contact Rosemount National Response Center at 1-800-THE-RSMT(1-800-654-7768). |

## Disassembly Procedure

Read the following information carefully before you disassemble a transmitter. General information concerning the process sensor body, electrical housing, and a procedure for their separation follow. Figure 4-1 shows an exploded view of the transmitter.

FIGURE 4-1. Differential Pressure (DP) Transmitter Exploded View, Shown with Smart Electronics.



## Process Sensor Body

Be aware of the following:

- The transmitter should be removed from service before disassembling the sensor body.
- Process flanges can be detached by removing the four large bolts.

### CAUTION

Do not scratch, puncture, or depress the isolating diaphragms. Damaging the isolating diaphragms can inhibit transmitter performance.

- Isolating diaphragms may be cleaned with a soft rag, mild cleaning solution, and clear water rinse.


### CAUTION

Do not use chlorine or acid solutions to clean the diaphragms. Damaging the isolating diaphragms can inhibit transmitter performance.

- Flange adapters and process flanges may be rotated or reversed for mounting convenience.



### Electrical Housing

 Electrical connections are located in a compartment identified as **TERMINAL SIDE** on the nameplate. The signal and test terminals are accessible by unscrewing the cover on the terminal side. The terminals are permanently attached to the housing and must not be removed, or the housing seal between compartments will be broken.

To remove the smart electronics, refer to Appendix C Retrofitting the Model 1151 Transmitter, and reverse the installation sequence described in steps 10 through 15.

### Removing the Sensor from the Electrical Housing

1. Unscrew the cover on the field terminal side of the transmitter.
2. Disconnect the power source from the transmitter.
3. Remove the smart electronics and header board.
4. Loosen the lock nut.

#### CAUTION

Do not damage the isolating diaphragms when unscrewing the sensor module. Damaging the isolating diaphragms can inhibit transmitter performance.

5. The threaded connection has a sealing compound on it and will initially be tight. Unscrew the sensing module from the electronics housing, being careful not to damage the sensor leads. Carefully pull the header assembly board through the hole.

The sensing module is a welded assembly and cannot be further disassembled.


### Reassembly Procedure

Follow these procedures carefully to ensure proper reassembly.

#### Preliminary Precaution

Inspect all O-rings and replace if necessary. Lightly grease with silicone oil to ensure a good seal. Use halocarbon grease for inert fill options.

### Connecting the Electrical Housing to the Sensor

- 
1. Insert the header assembly board through the electronics housing.
  2. Use a sealing compound (Loctite 222—Small Screw Threadlocker) on the threads of the sensor module to ensure a watertight seal on the housing.
  3. Screw the sensor module into the electrical housing making sure that at least five threads are engaged. Be careful not to damage or twist the sensor leads.
  4. Align the sensor module with the high and low pressure sides oriented for convenient installation.
  5. Tighten the lock nut.

### Electrical Housing

The smart electronics and header board can easily be installed in the electrical housing. Steps 10 through 15 in **Appendix C Retrofitting the Model 1151 Transmitter** describe this assembly.

#### CAUTION

An already characterized transmitter requires recharacterization whenever the sensor module or smart electronics are replaced. Failure to recharacterize can inhibit transmitter performance. (See Appendix C Retrofitting the Model 1151 Transmitter.)





**Process Sensor Body**

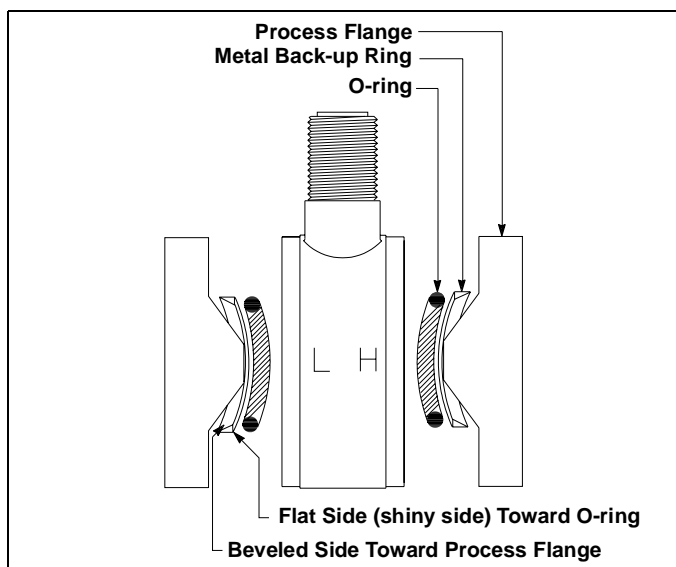
All HP transmitters and GP Range 9 and 10 transmitters require metal backup rings to ensure O-ring integrity. Figure 4-2 illustrates the position and orientation of the metal backup rings. (Backup rings are not required on AP or DP transmitters or GP Range 3-8 transmitters.)

**NOTE**

Handle the backup ring carefully, as it is fragile. Examine the ring carefully. One side is beveled, while the other side is flat. The flat side appears more shiny when viewed from above.

1. Clean the sealing surfaces carefully.
2. Place the module on a flat surface, “H” side up.
3. Place the greased flange O-ring around the isolator and push it into the cavity.

FIGURE 4-2. Detail Showing Process O-ring and Backup Ring Installation of Module Seal for Model 1151HP and GP Range 9 (GP Range 10 Requires Only One O-ring and Backup O-ring).



1151-0983A01A


4. For all HP transmitters and GP transmitters Ranges 9 and 10, place the backup ring, shiny side down, on top of the O-ring. This places the flat side of the backup ring against the O-ring.
5. Carefully place the flange on top of the module, beveled side down so that the beveled flange surface mates with the beveled surface of the backup ring.
6. Keeping the flange and module together, turn them over so the “L” side is up. Repeat Steps 3 through 5. As before, the flat side of the backup ring must rest against the O-ring.
7. Insert the four flange bolts.



8. Tighten the nuts finger tight, making sure the flanges remain parallel. The transmitter may now be moved without disturbing the O-rings.
  - a. Tighten one bolt until the flanges seat.
  - b. Torque down the bolt diagonally across.
  - c. Torque down the first bolt.
  - d. Torque down the two remaining bolts.
  - e. Inspect the flange-to-sensor seating to be sure that the flanges are not cocked.
  - f. Check that all four bolts are tightened to approximately 33 ft-lb (39 Nm).
9. Recalibrate the transmitter.

## Optional Plug-in Meters

The optional indicating meters available for Rosemount Model 1151 transmitters are listed in **Section 5 Specifications and Reference Data**. Please be aware of the following information while assembling the meter assembly. Refer to Table 5-12 on page 5-19 for part references.

- The meter may be rotated in 90-degree increments for convenient reading.
-  • If the meter cover is removed for any reason, be sure the O-ring is in place between the cover and housing before reattachment. To maintain an explosion-proof condition, the glass in the meter cover should not be disassembled for any reason.

## Sensor Module Checkout

The sensor module is not field repairable and must be replaced if found to be defective. If no obvious defect is observed (such as a punctured isolating diaphragm or fill fluid loss), the sensor module can be checked as follows.

1. Carefully pull the header assembly board off of the post connectors. Rotate the board 180 degrees about the axis formed by the connecting leads. The sensor module and electronics housing can remain attached for checkout.
2. Check internal diode loops, forward and reverse bias: one loop is on pins one and two, the other is on pins three and four. See Figure 4-3. Loop resistance values should be nearly equal.

---

### NOTE

Do not touch the transmitter housing when checking resistances, or a faulty reading can result.

---

3. Check the resistance between the sensor module housing and pins one through four. This checks the resistance between both capacitor plates and the sensing diaphragm, which is grounded to the housing. This resistance should be greater than 10 M $\Omega$ .
4. Check the resistance between pin eight and the sensor module to ensure that the module is grounded. Resistance should be zero.

---

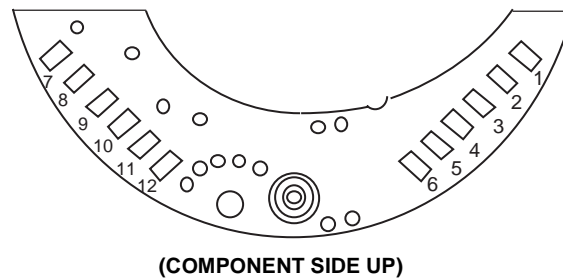
### NOTE

The above procedure does not completely test the sensor module. If circuit board replacement does not correct the abnormal condition, and no other problems are obvious, replace the sensor module.

---



FIGURE 4-3. Header Board Connections.




1151-0180B

### Returning Rosemount Products and/or Materials

To expedite the return process, call the Rosemount National Response Center using our 800-654-RSMT (7768) toll-free number. This center, available 24 hours a day, will assist you with any needed information or materials.

The center will ask for product model and serial numbers, and will provide a Return Material Authorization (RMA) number. For safety reasons, the center will also ask for the name of the process material the product was last exposed to.

 The National Response Center will detail the additional information and procedures necessary to return goods exposed to hazardous substances.



## Specifications and Reference Data

### FUNCTIONAL SPECIFICATIONS

#### Service

Liquid, gas, and vapor applications.

#### Ranges

Minimum span equals the upper range limit (URL) divided by rangedown. Rangedown varies with the output code (see Table 5-2).

TABLE 5-1. Model 1151 Transmitter Range Availability by Model (URL = Upper Range Limit).

| Range Code | Model 1151 Ranges (URL)            | DP | HP | GP | DP/GP/Seals | AP | LT |
|------------|------------------------------------|----|----|----|-------------|----|----|
| 2          | 6 inH <sub>2</sub> O (1.49 kPa)    | NA | NA | NA | NA          | NA | NA |
| 3          | 30 inH <sub>2</sub> O (7.46 kPa)   | •  | NA | •  | NA          | NA | NA |
| 4          | 150 inH <sub>2</sub> O (31.08 kPa) | •  | •  | •  | •           | •  | •  |
| 5          | 750 inH <sub>2</sub> O (186.4 kPa) | •  | •  | •  | •           | •  | •  |
| 6          | 100 psi (689.5 kPa)                | •  | •  | •  | •           | •  | •  |
| 7          | 300 psi (2068 kPa)                 | •  | •  | •  | •           | •  | NA |
| 8          | 1,000 psi (6895 kPa)               | •  | NA | •  | NA          | •  | NA |
| 9          | 3,000 psi (20684 kPa)              | NA | NA | •  | NA          | NA | NA |
| 0          | 6,000 psi (41369 kPa)              | NA | NA | •  | NA          | NA | NA |

TABLE 5-2. Rangeability.

| Output Code                   | Minimum Span | Maximum Span           |
|-------------------------------|--------------|------------------------|
| S (DP and GP, SST, Range 3–8) | URL/15       | 2 × URL <sup>(1)</sup> |
| S (All others)                | URL/6        | 2 × URL <sup>(1)</sup> |

(1) Transmitter is capable of measuring from –URL to URL.

### Outputs

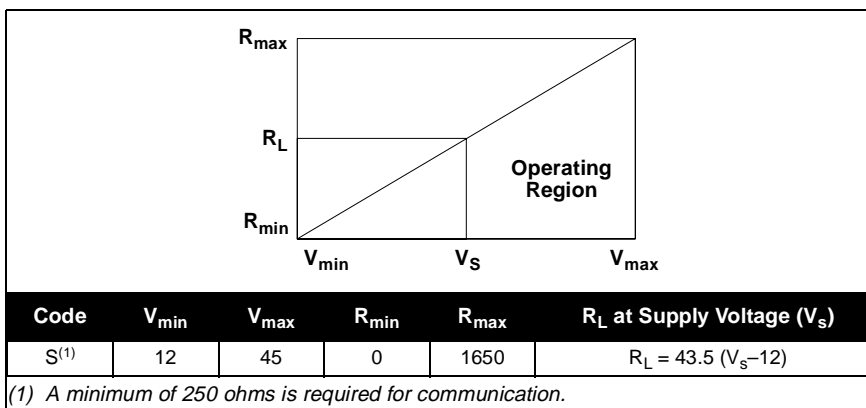
#### Code S, Smart

4–20 mA dc, user selectable for linear or square root output. Digital process variable superimposed on 4–20 mA signal, available to any host that conforms to the HART protocol.

#### Power Supply

External power supply required. Transmitter operates on:

12 to 45 V dc with no load for Output Code S. Where:



**Span and Zero**

**Output Code S**

Span and zero may be accessed with local adjustments or remotely via a HART-based communicator.

**Hazardous Locations Certifications**

Stainless steel certification tag is provided.

**Factory Mutual (FM) Approvals**

FM Explosion Proof tag is standard. Appropriate tag will be substituted if optional certification is selected.

**Default Explosion Proof:** Class I, Division 1, Groups B, C, and D.

**Dust-Ignition Proof:** Class II, Division 1, Groups E, F, and G.

Suitable for use in: Class III, Division 1. Indoor and outdoor use. NEMA 4X. Factory Sealed.

**I5** Intrinsic Safety and Non-incendive Approvals: FM certifications optional for specific Classes, Divisions, and Groups when connected in accordance with the FM entity approvals (see Table 5-3). Factory Sealed.

**K5** Combination of Explosion Proof, Intrinsic Safety, and Non-incendive Approvals.

TABLE 5-3. FM Entity Approvals.

| 1151 Parameters   | Equipment Associated Parameters   | FM Approved for Class I, II, III, Division 1 and 2 Groups |    |     |
|---|---|---|----|-----|
|   |   | A   | B  | C-G |
| $V_{Max} = 40\text{ V}$<br>$I_{Max} = 165\text{ mA}$<br>$C_i = 0$ (Standard)<br>$C_i = 0.024\ \mu\text{F}$ (Smart)<br>$C_i = 0.010\ \mu\text{F}$ (Standard w/R Option)<br>$C_i = 0.034\ \mu\text{F}$ (Smart w/R Option)<br>$L_i = 0$ (Standard)<br>$L_i = 20\ \mu\text{H}$ (w/R Option) | $V_{OC} \leq 40\text{ V}$<br>$I_{SC} \leq 165\text{ mA}$<br>$C_A > 0$<br>$C_A > 0.024\ \mu\text{F}$<br>$C_A > 0.010$<br>$C_A > 0.034$<br>$L_A > 0$<br>$L_A > 20\ \mu\text{H}$ | •   | •  | •   |
| $V_{Max} = 40\text{ V}$<br>$I_{Max} = 225\text{ mA}$<br>$C_i = 0$ (Standard)<br>$C_i = 0.024\ \mu\text{F}$ (Smart)<br>$L_i = 0$   | $V_{OC} \leq 40\text{ V}$<br>$I_{SC} \leq 225\text{ mA}$<br>$C_A > 0$<br>$C_A > 0.024\ \mu\text{F}$<br>$L_A > 0$  | NA  | NA | •   |

**Canadian Standards Association (CSA) Approvals**

**E6** Explosion proof for Class I, Division 1, Groups C and D; Class II, Division 1, Groups E, F, and G; Class III, Division 1 Hazardous Locations. Certified for Class I, Division 2, Groups A, B, C, and D; CSA enclosure 4. Factory sealed.

**I6** Intrinsic Safety Approvals CSA certifications optional for specific Classes, Divisions, and Groups when connected in accordance with the CSA barrier selection table, Table 5-4. Not available with Output Code G.

**C6** Combination of I6 and E6, CSA Explosion Proof and Intrinsic Safety Approval. Factory Sealed.

**K6** CSA/CENELEC Explosion-Proof and Intrinsic Safety Approval.

TABLE 5-4. CSA Barrier Selection.

| Barrier Manufacturer/Model  | CSA Approved for Class I, Division 1 and 2 Groups |    |   |   |
|---|---|----|---|---|
|   | A   | B  | C | D |
| Any CSA Approved Barrier $\leq 30$ V, $\geq 330 \Omega$ or $\leq 28$ V, $\geq 300 \Omega$ or $\leq 22$ V, $\geq 180 \Omega$   | •   | •  | • | • |
| Foxboro Converters 2AS-I3I-CGB, 2AI-I3V-CGB, 2AI-12V-CGB, 2AS-I2I-CGB, 3A2-I2D CS-E/CGB-A, 3F4-I2DAI CS-E/CGB-A, 3AD-I3IA CS-E/CGB-A, 3A2-I3D CS-E/CGB-A, and 3A4-I2DA CS-E/CGB-A | NA  | •  | • | • |
| Any CSA Approved Barrier $\leq 30$ V, $\geq 150 \Omega$   | NA  | NA | • | • |

**Standards Association of Australia (SAA)**

**E7 Flameproof Certification**

Ex d IIB T6; DIP T6; IP 65.  
Class I, Zone 1.

**Special Conditions:** For transmitters having NPT or PG cable entry threads, an appropriate flameproof thread adaptor shall be used to facilitate application of certified flameproof cable glands.

**I7 Intrinsic Safety Certification**

**Smart:** Ex ia IIC T6; Class I, Zone 0.

**Special Conditions:** Observe barrier/entity parameters during installation.

**N7 Type N**

Ex n IIC T6 ( $T_{amb} = 40 \text{ }^\circ\text{C}$ ).  
Ex n IIC T5 ( $T_{amb} = 70 \text{ }^\circ\text{C}$ ).  
Class I, Zone 2.

**Special Conditions:** The equipment must be connected to a supply voltage which does not exceed the rated voltage. The enclosure end caps must be correctly fitted whilst the equipment is energized.

**CESI/CENELEC Flameproof Certification**

**E8** 90.C.016: EEx d IIC T6 (without meter).  
90.C.017: EEx d IIB + H<sub>2</sub> T6 (with meter).  
IP 65.

**CESI/CENELEC Intrinsic Safety Certification**

**I8** EEx ia IIC T6 ( $T_{amb} = 40 \text{ }^\circ\text{C}$ ); ( $P_{max} = 0.75$  W).  
EEx ia IIC T5 ( $T_{amb} = 55 \text{ }^\circ\text{C}$ ); ( $P_{max} = 1.00$  W).  
EEx ia IIC T4 ( $T_{amb} = 80 \text{ }^\circ\text{C}$ ); ( $P_{max} = 1.00$  W).

**BASEEFA/CENELEC Intrinsic Safety Certification**

**I1 Smart:** Ex ia IIC T5 ( $T_{amb} = 40 \text{ }^\circ\text{C}$ ).  
EEx ia IIC T4 ( $T_{amb} = 80 \text{ }^\circ\text{C}$ ).

**Special Conditions:** When transient protection terminal options (R1 or R9) are installed, the transmitter must be supplied from a galvanically isolated i.s. barrier.

**BASEEFA Type N (Non-incendive) Certification**

**N1 Smart**

Ex N II T5 ( $T_{amb} = -40 \text{ }^\circ\text{C}$  to  $50 \text{ }^\circ\text{C}$ );  $U_n = 45$  V.  
Ex N II T4 ( $T_{amb} = -40 \text{ }^\circ\text{C}$  to  $80 \text{ }^\circ\text{C}$ );  $U_n = 45$  V.

**Special Conditions:** The apparatus must be installed in accordance with BS 5345: Part 7: 1979 and be earthed by means of enclosure earth terminal.

**Schweizerischer Elektrotechnischer Verein (SEV)  
Intrinsic Safety Certification  
IC Smart**

EEx ia IIC T5 ( $T_{amb} = 40\text{ }^{\circ}\text{C}$ ).

EEx ia IIC T4 ( $T_{amb} = 80\text{ }^{\circ}\text{C}$ ).

TABLE 5-5. International Entity Approvals.

| SAA (Australia)                  | SEV (Switzerland)                        | CESI (Italy)                     | BASEEFA (United Kingdom)            |
|----------------------------------|--|----------------------------------|-------------------------------------|
| $U_i = 30\text{ V}$              | $U_{max} = 29.4\text{ V}$                | Analog                           | $U_{max:in} = 28\text{ V dc}$       |
| $I_i = 200\text{ mA}$            | $I_{max} = 215\text{ mA}$                | Analog                           | $I_{max:in} = 120\text{ mA}$        |
| $C_i = 0.034\text{ }\mu\text{F}$ | $P_{max} = 0.35\text{ W (T6)}$           | Analog                           | $U_{max:in} = 30\text{ V dc}$       |
| $L_i = 20\text{ }\mu\text{H}$    | $P_{max} = 0.65\text{ W (T5)}$           | Analog                           | $I_{max:in} = 125\text{ mA}$        |
|                                  | $P_{max} = 0.95\text{ W (T4)}$           | Analog                           | $W_{max:in} = 0.67\text{ W (T5)}$   |
|                                  | $C_{int} = 0$                            | Analog                           | $W_{max:in} = 1.0\text{ W (T4)}$    |
|                                  | $U_{max} = 30\text{ V}$                  | Smart                            | $C_{eq} = 0.034\text{ }\mu\text{F}$ |
|                                  | $I_{max} = 125\text{ mA}$                | Smart                            | $L_{eq} = 20\text{ }\mu\text{H}$    |
|                                  | $P_{max} = 670\text{ mA}$                | Smart                            |                                     |
|                                  | $C_{int} = 0.22\text{ }\mu\text{F}$      | Smart                            |                                     |
|                                  | $L_{int} = 0\text{ (Digital Meter)}$     | Smart                            |                                     |
|                                  | $L_{int} = 0.7\text{ mH (Analog Meter)}$ | Smart                            |                                     |
|                                  |  |                                  |                                     |
|                                  |  | $U_i = 30\text{ V}$              | Smart                               |
|                                  |  | $I_i = 200\text{ mA}$            | Smart                               |
|                                  |  | $P_i = 0.75\text{ W (T6)}$       | Smart                               |
|                                  |  | $P_i = 1.0\text{ W (T5 and T4)}$ | Smart                               |
|                                  |  | $C_i = 0.01\text{ }\mu\text{F}$  | Smart                               |
|                                  |  | $L_i = 20\text{ }\mu\text{H}$    | Smart                               |
|                                  |  | $U_i = 30\text{ V}$              | Code R9                             |
|                                  |  | $I_i = 200\text{ mA}$            | Code R9                             |
|                                  |  | $P_i = 1.0\text{ W}$             | Code R9                             |
|                                  |  | $C_i = 6\text{ nF}$              | Code R9                             |
|                                  |  | $L_i = 20\text{ }\mu\text{H}$    | Code R9                             |

**Zero Elevation and Suppression**

**Output Code S**

Zero elevation and suppression must be such that the lower range value is greater than or equal to the (-URL) and the upper range value is less than or equal to the (+URL). The calibrated span must be greater than or equal to the minimum span.

**Temperature Limits**

**Ambient**

-40 to 185 °F (-40 to 85 °C).

**Process** At atmospheric pressures and above.

TABLE 5-6. Model 1151 Temperature Limits.

| Models 1151DP, HP, AP, GP, LT                                     |                                |
|---|--------------------------------|
| Silicone Fill Sensor  | -40 to 220 °F (-40 to 104 °C)  |
| Inert Fill Sensor   | 0 to 160 °F (-18 to 71 °C)     |
| Model 1151LT High-Side Temperature Limits<br>(Process Fill Fluid) |                                |
| Syltherm® XLT   | -100 to 300 °F (-73 to 149 °C) |
| D.C.® Silicone 704  | 60 to 400 °F (15 to 205 °C)    |
| D.C. Silicone 200   | -40 to 400 °F (-40 to 205 °C)  |
| Inert   | -50 to 350 °F (-45 to 177 °C)  |
| Glycerin and Water <sup>(1)</sup>                                 | 0 to 200 °F (-18 to 93 °C)     |
| Neobee M-20 <sup>(2)</sup>  | 0 to 400 °F (-18 to 205 °C)    |
| Propylene Glycol and Water <sup>(2)</sup>                         | 0 to 200 °F (-18 to 93 °C)     |
| Syltherm 800  | -50 to 400 °F (-45 to 205 °C)  |

(1) Not suitable for vacuum service.

(2) Not compatible with Buna-N or Ethylene-Propylene O-ring material.

**NOTE**

When specifying Option Codes W4 and W6, sensing element operating temperatures are 32 to 200 °F (0 to 93 °C) for silicone fill and 32 to 160 °F (0 to 71 °C) for inert fill.

**Storage**

-60 to 185 °F (-51 to 85 °C).



**Static Pressure Limits**

Transmitters operate within specifications between the following limits:

**Model 1151DP**

0.5 psia to 2,000 psig (3.45 kPa to 13790 kPa).

**Model 1151HP**

0.5 psia to 4,500 psig (3.45 kPa to 31027 kPa).

**Model 1151AP**

0 psia to the URL.

**Model 1151GP**

0.5 psia (3.45 kPa) to the URL.

**Model 1151LT**

Limit is 0.5 psia (3.45 kPa) to the flange rating or sensor rating, whichever is lower.

**Overpressure Limits**

Transmitters withstand the following limits without damage:

**Model 1151DP**

0 psia to 2,000 psig (0 to 13790 kPa).

**Model 1151HP**

0 psia to 4,500 psig (0 to 31027 kPa).

**Model 1151AP**

0 psia to 2,000 psia (0 to 13790 kPa).

**Model 1151GP:**

Ranges 3–8: 0 psia to 2,000 psig (0 to 13790 kPa).

Range 9: 0 psia to 4,500 psig (31027 kPa).

Range 0: 0 psia to 7,500 psig (51710 kPa).

**Model 1151LT:**

Limit is 0 psia to the flange rating or sensor rating, whichever is lower.

TABLE 5-7. Model 1151LT and Level Flange Rating Limits.

| Standard | Class    | Carbon Steel Rating       | Stainless Steel Rating    |
|----------|----------|---------------------------|---------------------------|
| ANSI     | 150      | 285 psig <sup>(1)</sup>   | 275 psig <sup>(1)</sup>   |
| ANSI     | 300      | 740 psig <sup>(1)</sup>   | 720 psig <sup>(1)</sup>   |
| ANSI     | 600      | 1,480 psig <sup>(1)</sup> | 1,440 psig <sup>(1)</sup> |
| DIN      | PN 10–40 | 40 bar <sup>(2)</sup>     | 40 bar <sup>(2)</sup>     |
| DIN      | PN 10/16 | 16 bar <sup>(2)</sup>     | 16 bar <sup>(2)</sup>     |
| DIN      | PN 25/40 | 40 bar <sup>(2)</sup>     | 40 bar <sup>(2)</sup>     |

(1) At 100 °F (38 °C), the rating decreases with increasing temperature.

(2) At 248 °F (120 °C), the rating decreases with increasing temperature.

**Burst Pressure Limit**

All models: 10,000 psig (68.95 MPa) burst pressure on the flanges.

**Humidity Limits**

0 to 100% relative humidity.

**Volumetric Displacement**

Less than 0.01 in<sup>3</sup> (0.16 cm<sup>3</sup>).

**Failure Mode Alarm**

When not in multidrop mode, self-diagnosis detects a gross transmitter failure, the analog signal will be driven below 3.9 mA or above 21 mA to alert the user. High or low alarm signal is user selectable.

| Level | 4–20 mA Saturation Value | 4–20 mA Alarm Value |
|-------|--------------------------|---------------------|
| Low   | 3.9 mA                   | 3.8 mA              |
| High  | 20.8 mA                  | 21.75 mA            |

**Transmitter Security**

Activating the transmitter security function prevents changes to the transmitter configuration, including local zero and span adjustments. Security is activated by an internal switch.

**Overpressure Alarm**

If the sensor detects a negative overpressure value, the analog signal will be driven to 3.9 mA. If the sensor detects a positive overpressure value, the analog signal is driven to 20.8 mA.

**Damping**

Numbers given are for silicone fill fluid at room temperature. The minimum time constant is 0.2 seconds (0.4 seconds for Range 3). Inert-filled sensor values would be slightly higher.

**Output Code S:**

Time constant is adjustable in 0.1 second increments from minimum to 16.0 seconds.

**Turn-on Time**

Maximum of 2.0 seconds with minimum damping. Low power output is within 0.2% of steady state value within 200 ms after application of power.

## PERFORMANCE SPECIFICATIONS

(Zero-based calibrated ranges, reference conditions, silicone oil fill, 316 SST isolating diaphragms.)

### Accuracy

#### Output Code S:

Ranges 3 through 8, DP and GP transmitters:

±0.1% of calibrated span for spans from 1:1 to 10:1 of URL.

Between 10:1 and 15:1 of URL,

$$\text{accuracy} = \pm \left[ 0.02 \left( \frac{\text{URL}}{\text{span}} \right) - 0.1 \right] \% \text{ of calibrated span}$$

All other ranges and transmitters:

±0.25% of calibrated span.

#### Output Code S, square root mode:

$$\pm \left[ 0.2 + 0.05 \times \frac{\text{URL}}{\text{span}} \right] \% \text{ of calibrated flow span}$$

### Stability

#### Output Code S:

±0.1% of URL for six months for DP and GP Ranges 3 through 8.

(±0.25% for all other ranges and transmitters.)

### Temperature Effect

#### Output Code S [–20 to 185 °F (–29 to 85 °C)]:

For DP and GP transmitter Range 4 through 8:

Zero Error = ±0.2% URL per 100 °F (56 °C)

Total Error = ±(0.2% URL + 0.18% of calibrated span) per 100 °F; double the effect for other ranges and transmitters.

### Static Pressure Effect

#### DP Transmitters:

**Zero Error:** ±0.25% of URL for 2,000 psi (13790 kPa) or ±0.5% for Range 3, correctable through rezeroing at line pressure.

**Span Error:** Correctable to ±0.25% of input reading per 1,000 psi (6895 kPa), or to ±0.5% for Range 3. For Output Code J, the span error is correctable to ±0.125% of output reading per 1,000 psi, or to ±0.25% for Range 3.

#### HP Transmitters:

**Zero Error:** ±2.0% of URL for 4,500 psi (31027 kPa), correctable through rezeroing at line pressure.

**Span Error:** Correctable to ±0.25% of input reading per 1,000 psi (6895 kPa).

For Output Code J, the span error is correctable to ±0.125% of output reading per 1,000 psi, or to ±0.25% for Range 3.

### Vibration Effect

0.05% of URL per g to 200 Hz in any axis.

### Power Supply Effect

#### Output Code S:

Less than 0.005% of output span per volt.

## PHYSICAL SPECIFICATIONS

### Load Effect

#### Output Code S:

No load effect other than the change in power supplied to the transmitter.

### EMI/RFI Effect

Output shift of less than 0.1% of span when tested to SAMA PMC 33.1 from 20 to 1000 MHz and for field strengths up to 30 V/m (covers on).

### Mounting Position Effect

Zero shift of up to 1 inH<sub>2</sub>O (0.24 kPa) that can be calibrated out.

### Electrical Connections

½–14 NPT conduit with screw terminals and integral test jacks compatible with miniature banana plugs (Pomona 2944, 3690, or equivalent). The communicator connections are fixed to the terminal block on smart transmitters.

### Process Connections

#### Model 1151DP, HP, GP, AP

¼–18 NPT on 2.125-in. (54-mm) centers on flanges for Ranges 3, 4, and 5.

¼–18 NPT on 2.188-in. (56-mm) centers on flanges for Ranges 6 and 7.

¼–18 NPT on 2.250-in. (57-mm) centers on flanges for Range 8.

½–14 NPT on adaptors.

For Ranges 3, 4, and 5, flange adaptors can be rotated to give centers of 2.0 in. (51 mm), 2.125 in. (54 mm), or 2.250 in. (57 mm).

#### Model 1151LT

High pressure side: 2-, 3-, or 4-in., Class 150, 300 or 600 flange; 50, 80, or 100 mm, PN 40 or 10/16 flange.

Low pressure side: ¼–18 NPT on flange. ½–14 NPT on adapter.

### Process Wetted Parts

#### Isolating Diaphragms

316L SST, Hastelloy C-276, Monel, gold-plated Monel, or Tantalum. See ordering table for availability per model type.

#### Drain/Vent Valves

316 SST, Hastelloy C-276, or Monel. See ordering table for availability per model type.

#### Process Flanges and Adaptors

Plated carbon steel, 316 SST, Hastelloy C, or Monel. See ordering table for availability per model type.

#### Wetted O-rings

Viton<sup>®(1)</sup> (other materials also available). With gold-plated Monel diaphragms (diaphragm Code \_6), special fluorocarbon O-rings are supplied.

(1) For enhanced sealing performance below 0 °F, consult factory.

**Model 1151LT Process Wetted Parts**

**Flanged Process Connection  
(Transmitter High Side)**

**Process diaphragms, including process gasket surface**  
316L SST, Hastelloy C-276, or Tantalum.

**Extension**  
316 SST or Hastelloy C-276. Fits schedule 40 and 80 pipe.

**Mounting Flange**  
Cadmium-plated CS or SST.

**Reference Process Connection  
(Transmitter Low Side)**

**Isolating Diaphragms**  
316L SST, Hastelloy C-276, or tantalum.

**Reference Flange and Adapter**  
CF-8M (Cast version of 316 SST, material per ASTM-A743).

**Non-wetted Materials**

**Fill Fluid**  
Silicone oil or inert fill.

**Bolts and Bolting Flange (GP and AP only)**  
Plated carbon steel.

**Electronics Housing**  
Low-copper aluminium. NEMA 4X.

**Cover O-rings**  
Buna-N.

**Paint**  
Polyurethane.

**Weight**

12 lb (5.4 kg) for AP, DP, GP, and HP transmitters, excluding options.

TABLE 5-8. Flange Weights with Model 1151LT Transmitter.

| Flange <sup>(1)</sup> | Flush Mount | 2-inch (50mm) Extension | 4-inch (100mm) Extension | 6-inch (150mm) Extension |
|-----------------------|-------------|-------------------------|--------------------------|--------------------------|
| 2-in., Class 150      | 18 (8.2)    | N/A                     | N/A                      | N/A                      |
| 3-in., Class 150      | 23 (10.4)   | 25 (11.3)               | 26 (11.8)                | 27 (12.3)                |
| 4-in., Class 150      | 29 (13.2)   | 32 (14.5)               | 34 (15.4)                | 36 (16.3)                |
| 2-in., Class 300      | 20 (9.1)    | N/A                     | N/A                      | N/A                      |
| 3-in., Class 300      | 28 (12.7)   | 30 (13.6)               | 31 (14.1)                | 32 (14.5)                |
| 4-in., Class 300      | 38 (17.2)   | 41 (18.6)               | 43 (19.5)                | 45 (20.4)                |
| 2-in., Class 600      | 22 (10.0)   | N/A                     | N/A                      | N/A                      |
| 3-in., Class 600      | 31 (14.1)   | 33 (15.0)               | 34 (15.4)                | 35 (15.9)                |
| DN 50, PN10-40        | 20 (9.1)    | N/A                     | N/A                      | N/A                      |
| DN 80, PN 25/40       | 25 (11.3)   | 27 (12.3)               | 28 (12.7)                | 29 (13.2)                |
| DN 100, PN 10/16 DN   | 25 (11.3)   | 28 (12.7)               | 30 (13.6)                | 32 (14.5)                |
| 100, PN 25/40         | 29 (13.2)   | 32 (14.5)               | 34 (15.4)                | 36 (16.3)                |

(1) Stainless steel flange weights are listed.

**ORDERING INFORMATION**

TABLE 5-9. Model 1151 Differential, High Line, Gage and Absolute Pressure Transmitters.

| Model  | Transmitter Type (select one)                                  |   |                   |            | DP  | HP | GP                | AP       |  |        |                |            |         |                |   |         |   |       |   |   |   |   |
|--|--|---|-------------------|------------|---|----|-------------------|----------|--|--------|----------------|------------|---------|----------------|---|---------|---|-------|---|---|---|---|
| 1151DP   | Differential Pressure Transmitter                              |   |                   |            | •   | —  | —                 | —        |  |        |                |            |         |                |   |         |   |       |   |   |   |   |
| 1151HP   | Differential Pressure Transmitter for High Line Pressures      |   |                   |            | —   | •  | —                 | —        |  |        |                |            |         |                |   |         |   |       |   |   |   |   |
| 1151GP   | Gage Pressure Transmitter                                      |   |                   |            | —   | —  | •                 | —        |  |        |                |            |         |                |   |         |   |       |   |   |   |   |
| 1151AP   | Absolute Pressure Transmitter                                  |   |                   |            | —   | —  | —                 | •        |  |        |                |            |         |                |   |         |   |       |   |   |   |   |
|  |  |   |                   |            | <table border="1"> <thead> <tr> <th colspan="2">Key</th> </tr> </thead> <tbody> <tr> <td>•</td> <td>Applicable</td> </tr> <tr> <td>—</td> <td>Not applicable</td> </tr> </tbody> </table> |    |                   |          | Key  |        | •              | Applicable | —       | Not applicable |   |         |   |       |   |   |   |   |
| Key  |  |   |                   |            |   |    |                   |          |  |        |                |            |         |                |   |         |   |       |   |   |   |   |
| •  | Applicable   |   |                   |            |   |    |                   |          |  |        |                |            |         |                |   |         |   |       |   |   |   |   |
| —  | Not applicable   |   |                   |            |   |    |                   |          |  |        |                |            |         |                |   |         |   |       |   |   |   |   |
| Code   | Pressure Ranges (URL) (select one)—For Rangeability, see below |   |                   |            | DP  | HP | GP                | AP       |  |        |                |            |         |                |   |         |   |       |   |   |   |   |
| 3  | 30 inH <sub>2</sub> O (7.46 kPa)                               | <table border="1"> <thead> <tr> <th colspan="2">Rangeability</th> </tr> <tr> <th>Output Code</th> <th>Min.Span</th> </tr> </thead> <tbody> <tr> <td>S (DP and GP, SST, Range 3–8;<br/>HP, SST, Range 4–7)</td> <td>URL/15</td> </tr> <tr> <td>S (all others)</td> <td>URL/6</td> </tr> <tr> <td>E, G, J</td> <td>URL/6</td> </tr> <tr> <td>L</td> <td>URL/1.1</td> </tr> <tr> <td>M</td> <td>URL/2</td> </tr> </tbody> </table> |                   |            | Rangeability  |    | Output Code       | Min.Span | S (DP and GP, SST, Range 3–8;<br>HP, SST, Range 4–7) | URL/15 | S (all others) | URL/6      | E, G, J | URL/6          | L | URL/1.1 | M | URL/2 | • | — | • | — |
| Rangeability   |  |   |                   |            |   |    |                   |          |  |        |                |            |         |                |   |         |   |       |   |   |   |   |
| Output Code  | Min.Span   |   |                   |            |   |    |                   |          |  |        |                |            |         |                |   |         |   |       |   |   |   |   |
| S (DP and GP, SST, Range 3–8;<br>HP, SST, Range 4–7) | URL/15   |   |                   |            |   |    |                   |          |  |        |                |            |         |                |   |         |   |       |   |   |   |   |
| S (all others)                                       | URL/6  |   |                   |            |   |    |                   |          |  |        |                |            |         |                |   |         |   |       |   |   |   |   |
| E, G, J  | URL/6  |   |                   |            |   |    |                   |          |  |        |                |            |         |                |   |         |   |       |   |   |   |   |
| L  | URL/1.1  |   |                   |            |   |    |                   |          |  |        |                |            |         |                |   |         |   |       |   |   |   |   |
| M  | URL/2  |   |                   |            |   |    |                   |          |  |        |                |            |         |                |   |         |   |       |   |   |   |   |
| 4  | 150 inH <sub>2</sub> O (37.3 kPa)                              | •   | •                 | •          | •   |    |                   |          |  |        |                |            |         |                |   |         |   |       |   |   |   |   |
| 5  | 750 inH <sub>2</sub> O (186.4 kPa)                             | •   | •                 | •          | •   |    |                   |          |  |        |                |            |         |                |   |         |   |       |   |   |   |   |
| 6  | 100 psi (689.5 kPa)  | •   | •                 | •          | •   |    |                   |          |  |        |                |            |         |                |   |         |   |       |   |   |   |   |
| 7  | 300 psi (2068 kPa)   | •   | •                 | •          | •   |    |                   |          |  |        |                |            |         |                |   |         |   |       |   |   |   |   |
| 8  | 1,000 psi (6895 kPa)   | •   | —                 | •          | •   |    |                   |          |  |        |                |            |         |                |   |         |   |       |   |   |   |   |
| 9  | 3,000 psi (20684 kPa)  | —   | —                 | •          | —   |    |                   |          |  |        |                |            |         |                |   |         |   |       |   |   |   |   |
| 0  | 6,000 psi (41369 kPa)  | —   | —                 | •          | —   |    |                   |          |  |        |                |            |         |                |   |         |   |       |   |   |   |   |
| Code   | Transmitter Output (select one)                                |   |                   |            | DP  | HP | GP                | AP       |  |        |                |            |         |                |   |         |   |       |   |   |   |   |
| S  | 4–20 mA/Digital, Smart/Variable Damping                        |   |                   |            | •   | •  | •                 | •        |  |        |                |            |         |                |   |         |   |       |   |   |   |   |
| E  | 4–20 mA, Linear, Analog/Variable Damping                       |   |                   |            | •   | •  | •                 | •        |  |        |                |            |         |                |   |         |   |       |   |   |   |   |
| G  | 10–50 mA, Linear, Analog/Variable Damping                      |   |                   |            | •   | •  | •                 | •        |  |        |                |            |         |                |   |         |   |       |   |   |   |   |
| J  | 4–20 mA, Square Root, Analog/Variable Damping                  |   |                   |            | •   | •  | —                 | —        |  |        |                |            |         |                |   |         |   |       |   |   |   |   |
| L  | 0.8 to 3.2 V, Linear, Low Power/Fixed Damping                  |   |                   |            | •   | •  | •                 | •        |  |        |                |            |         |                |   |         |   |       |   |   |   |   |
| M  | 1 to 5 V, Linear, Low Power/Fixed Damping                      |   |                   |            | •   | •  | •                 | •        |  |        |                |            |         |                |   |         |   |       |   |   |   |   |
| MATERIALS OF CONSTRUCTION <sup>(1)</sup>             |  |   |                   |            |   |    |                   |          |  |        |                |            |         |                |   |         |   |       |   |   |   |   |
| Code   | Flanges/Adapters   | Drain/Vents   | Diaphragms        | Fill Fluid | DP  | HP | GP <sup>(2)</sup> | AP       |  |        |                |            |         |                |   |         |   |       |   |   |   |   |
| 52   | Nickel-plated Carbon Steel                                     | 316 SST   | 316L SST          | Silicone   | •   | •  | •                 | •        |  |        |                |            |         |                |   |         |   |       |   |   |   |   |
| 53   | Nickel-plated Carbon Steel                                     | 316 SST   | Hastelloy C-276   | Silicone   | •   | •  | •                 | •        |  |        |                |            |         |                |   |         |   |       |   |   |   |   |
| 54   | Nickel-plated Carbon Steel                                     | 316 SST   | Monel             | Silicone   | •   | •  | •                 | •        |  |        |                |            |         |                |   |         |   |       |   |   |   |   |
| 55   | Nickel-plated Carbon Steel                                     | 316 SST   | Tantalum          | Silicone   | •   | —  | •                 | —        |  |        |                |            |         |                |   |         |   |       |   |   |   |   |
| 56   | Nickel-plated Carbon Steel                                     | 316 SST   | Gold-plated Monel | Silicone   | •   | —  | •                 | —        |  |        |                |            |         |                |   |         |   |       |   |   |   |   |
| 12   | Cadmium-plated Carbon Steel                                    | 316 SST   | 316L SST          | Silicone   | •   | •  | •                 | •        |  |        |                |            |         |                |   |         |   |       |   |   |   |   |
| 22   | 316 SST  | 316 SST   | 316L SST          | Silicone   | •   | •  | •                 | •        |  |        |                |            |         |                |   |         |   |       |   |   |   |   |
| 23   | 316 SST  | 316 SST   | Hastelloy C-276   | Silicone   | •   | •  | •                 | •        |  |        |                |            |         |                |   |         |   |       |   |   |   |   |
| 24   | 316 SST  | 316 SST   | Monel             | Silicone   | •   | •  | •                 | •        |  |        |                |            |         |                |   |         |   |       |   |   |   |   |
| 25   | 316 SST  | 316 SST   | Tantalum          | Silicone   | •   | —  | •                 | —        |  |        |                |            |         |                |   |         |   |       |   |   |   |   |
| 26   | 316 SST  | 316 SST   | Gold-plated Monel | Silicone   | •   | —  | •                 | —        |  |        |                |            |         |                |   |         |   |       |   |   |   |   |
| 33 <sup>(3)</sup>                                    | Hastelloy C  | Hastelloy C-276   | Hastelloy C-276   | Silicone   | •   | •  | •                 | •        |  |        |                |            |         |                |   |         |   |       |   |   |   |   |
| 34   | Hastelloy C  | Hastelloy C-276   | Monel             | Silicone   | •   | —  | •                 | —        |  |        |                |            |         |                |   |         |   |       |   |   |   |   |
| 35   | Hastelloy C  | Hastelloy C-276   | Tantalum          | Silicone   | •   | —  | •                 | —        |  |        |                |            |         |                |   |         |   |       |   |   |   |   |

(1) Bolts and conduit plugs are plated carbon steel.  
 (2) On GP and AP transmitters, the low-side flange is plated carbon steel.  
 For a stainless-steel low-side flange, order process connection Option Code D6.  
 (3) These selections meet NACE material recommendations per MR 01-75.

TABLE 5-9. (continued).

| MATERIALS OF CONSTRUCTION <sup>(1)</sup> |                             |                 |                   |            |    |    |                   |    |
|--|-----------------------------|-----------------|-------------------|------------|----|----|-------------------|----|
| Code                                     | Flanges/Adapters            | Drain/Vents     | Diaphragms        | Fill Fluid | DP | HP | GP <sup>(2)</sup> | AP |
| 36                                       | Hastelloy C                 | Hastelloy C-276 | Gold-plated Monel | Silicone   | •  | —  | •                 | —  |
| 43                                       | Monel                       | Monel           | Hastelloy C-276   | Silicone   | •  | •  | •                 | •  |
| 44                                       | Monel                       | Monel           | Monel             | Silicone   | •  | •  | •                 | •  |
| 45                                       | Monel                       | Monel           | Tantalum          | Silicone   | •  | —  | •                 | —  |
| 46                                       | Monel                       | Monel           | Gold-plated Monel | Silicone   | •  | —  | •                 | —  |
| 73 <sup>(3)</sup>                        | 316 SST                     | Hastelloy C-276 | Hastelloy C-276   | Silicone   | •  | •  | •                 | •  |
| 83 <sup>(3)</sup>                        | Nickel-plated Carbon Steel  | Hastelloy C-276 | Hastelloy C-276   | Silicone   | •  | •  | •                 | •  |
| 5A                                       | Nickel-plated Carbon Steel  | 316 SST         | 316L SST          | Inert      | •  | —  | •                 | —  |
| 5B                                       | Nickel-plated Carbon Steel  | 316 SST         | Hastelloy C-276   | Inert      | •  | —  | •                 | —  |
| 5C                                       | Nickel-plated Carbon Steel  | 316 SST         | Monel             | Inert      | •  | —  | •                 | —  |
| 5D                                       | Nickel-plated Carbon Steel  | 316 SST         | Tantalum          | Inert      | •  | —  | •                 | —  |
| 1A                                       | Cadmium-plated Carbon Steel | 316 SST         | 316L SST          | Inert      | •  | —  | •                 | —  |
| 2A                                       | 316 SST                     | 316 SST         | 316L SST          | Inert      | •  | —  | •                 | —  |
| 2B                                       | 316 SST                     | 316 SST         | Hastelloy C-276   | Inert      | •  | —  | •                 | —  |
| 2D                                       | 316 SST                     | 316 SST         | Tantalum          | Inert      | •  | —  | •                 | —  |
| 3B                                       | Hastelloy C                 | Hastelloy C-276 | Hastelloy C-276   | Inert      | •  | —  | •                 | —  |
| 3D                                       | Hastelloy C                 | Hastelloy C-276 | Tantalum          | Inert      | •  | —  | •                 | —  |
| 4B                                       | Monel                       | Monel           | Hastelloy C-276   | Inert      | •  | —  | •                 | —  |
| 4C                                       | Monel                       | Monel           | Monel             | Inert      | •  | —  | •                 | —  |
| 4D                                       | Monel                       | Monel           | Tantalum          | Inert      | •  | —  | •                 | —  |
| 7B <sup>(3)</sup>                        | 316 SST                     | Hastelloy C-276 | Hastelloy C-276   | Inert      | •  | —  | •                 | —  |
| 8B <sup>(3)</sup>                        | Nickel-plated Carbon Steel  | Hastelloy C-276 | Hastelloy C-276   | Inert      | •  | —  | •                 | —  |

- (1) Bolts and conduit plugs are plated carbon steel.
- (2) On GP and AP transmitters, the low-side flange is plated carbon steel.  
For a stainless-steel low-side flange, order process connections Option Code D6.
- (3) These selections meet NACE material recommendations per MR 01-75.

TABLE 5-9. (continued).

| Code              | Mounting Brackets (optional – select one)        | DP | HP | GP | AP |
|-------------------|--|----|----|----|----|
| B1                | Bracket, 2-in. Pipe Mount                        | •  | •  | •  | •  |
| B2                | Bracket, Panel Mount                             | •  | •  | •  | •  |
| B3                | Bracket, Flat, 2-in. Pipe Mount                  | •  | •  | •  | •  |
| B4                | B1 Bracket w/Series 316 SST Bolts                | •  | •  | •  | •  |
| B5                | B2 Bracket w/Series 316 SST Bolts                | •  | •  | •  | •  |
| B6                | B3 Bracket w/Series 316 SST Bolts                | •  | •  | •  | •  |
| B7                | 316 SST B1 Bracket with 316 SST Bolts            | •  | •  | •  | •  |
| B9                | 316 SST B3 Bracket with 316 SST Bolts            | •  | •  | •  | •  |
| Code              | Meters (optional - select one)                   | DP | HP | GP | AP |
| M1 <sup>(1)</sup> | Analog Scale, Linear Meter, 0–100%               | •  | •  | •  | •  |
| M2 <sup>(2)</sup> | Analog Scale, Square Root Meter, 0–100% Flow     | •  | •  | —  | —  |
| M3 <sup>(1)</sup> | Analog Scale, Linear Meter, Special Scale        | •  | •  | •  | •  |
| M4 <sup>(1)</sup> | LCD Meter, Linear Meter, 0–100%, User Selectable | •  | •  | •  | •  |
| M6 <sup>(2)</sup> | Analog Scale, Square Root Meter, 1–10√           | •  | •  | —  | —  |
| M7 <sup>(3)</sup> | LCD Meter, Linear Meter, Special Configuration   | •  | •  | •  | •  |
| M8 <sup>(4)</sup> | LCD Meter Square Root Meter, 0–100% Flow         | •  | •  | —  | —  |
| M9 <sup>(4)</sup> | LCD Meter, Square Root Meter, 0–10√              | •  | •  | —  | —  |

- (1) Not available with Output Codes L or M, or Option Codes Zx, V2, or V3.
- (2) Not available with Output Codes J, L, M, or Option Codes Zx, V2, or V3.
- (3) Not available with Output Codes G, L, M, or Option Codes Zx, V2, or V3.
- (4) Not available with Output Codes G, J, L, M, or Option Codes Zx, V2, or V3.





TABLE 5-9. (continued).

| Code              | Process Connections (optional <sup>(1)</sup> )  | DP              | HP | GP | AP |   |
|-------------------|---|-----------------|----|----|----|---|
| D1                | Side Drain/Vent, Top  | 316 SST         | •  | •  | •  | • |
|                   |   | Hastelloy C-276 | •  | •  | •  | • |
|                   |   | Monel           | •  | •  | •  | • |
| D2                | Side Drain/Vent, Bottom   | 316 SST         | •  | •  | •  | • |
|                   |   | Hastelloy C-276 | •  | •  | •  | • |
|                   |   | Monel           | •  | •  | •  | • |
| D3                | Process Adapters Deleted  | 316 SST         | •  | •  | •  | • |
|                   |   | Hastelloy C     | •  | •  | •  | • |
|                   |   | Monel           | •  | •  | •  | • |
| D4                | Conformance to DIN 19213 and DIN 50049 3.1B Ranges 3, 4, 5 (Available in Germany Only)  | •               | •  | •  | •  |   |
| D5                | Conformance to DIN 19213 and DIN 50049 3.1B Ranges 6, 7, 8, without ¼ NPT Threads or Drain/Vent Valve Connections (Available in Germany Only) | •               | •  | •  | •  |   |
| D6                | 316 SST Low Side Blank Flange   | —               | —  | •  | •  |   |
| D9                | JIS Process Connection—RC ¼ Flange with RC ½ Flange Adapter   | Carbon Steel    | •  | •  | •  | • |
|                   |   | 316 SST         | •  | •  | •  | • |
|                   |   | Hastelloy C     | •  | •  | •  | • |
|                   |   | Monel           | •  | •  | •  | • |
| G1                | DIN Spacing (Single Entry Port, No Side V/D Hole Flange)  | •               | •  | •  | •  |   |
| G2                | DIN Spacing (Single Entry Port, Two Side V/D Hole Flange)   | •               | •  | •  | •  |   |
| G3                | DIN Spacing (Dual Entry Port, No Side V/D Hole Flange)  | •               | •  | •  | •  |   |
| G4                | DIN Spacing (Dual Entry Port, One Top Side V/D Hole Flange)   | •               | •  | •  | •  |   |
| G5                | DIN Spacing (Dual Entry Port, One Bottom Side V/D Hole Flange)  | •               | •  | •  | •  |   |
| G6                | DIN Spacing (Dual Entry Port, Two Side V/D Hole Flange)   | •               | •  | •  | •  |   |
| K1 <sup>(2)</sup> | Kynar insert, ¼–18 NPT  | •               | —  | •  | •  |   |
| K2 <sup>(2)</sup> | Kynar insert, ½–14 NPT  | •               | —  | •  | •  |   |
| S1 <sup>(3)</sup> | Attachment of One Remote Seal - See PDS 00813-0100-4016   | •               | —  | •  | —  |   |
| S2 <sup>(3)</sup> | Attachment of Two Remote Seals - See PDS 00813-0100-4016  | •               | —  | —  | —  |   |
| S4 <sup>(4)</sup> | Attachment of Integral Orifice Assembly - See PDS 00813-0100-4686   | •               | •  | —  | —  |   |

(1) Allowable combinations are: D1, D3, D6; D2, D3, D6; and D6, S1.

(2) The maximum working pressure on this option is 300 psig. Available only with materials of construction Option Codes 1x or 2x.

(3) This option may only be used on Ranges 4–8.

(4) This option has a maximum static pressure rating of 3,000 psi, and is available for factory assembly only without associated piping and is available only for Ranges 2, 3, 4, and 5.

TABLE 5-9. (continued).

| Code              | Wetted O-ring Material                             | DP | HP | GP | AP |
|-------------------|--|----|----|----|----|
| W2                | Buna-N   | •  | •  | •  | •  |
| W3                | Ethylene-Propylene                                 | •  | •  | •  | •  |
| W4                | Aflas  | •  | •  | •  | •  |
| W6 <sup>(1)</sup> | Spring-loaded Teflon                               | •  | —  | •  | •  |
| Code              | Procedures   | DP | HP | GP | AP |
| C9 <sup>(2)</sup> | Software Configuration                             | •  | •  | •  | •  |
| P1 <sup>(3)</sup> | Hydrostatic Testing, 150% Maximum Working Pressure | •  | •  | •  | •  |
| P2 <sup>(4)</sup> | Cleaning for Special Service                       | •  | •  | •  | •  |
| P3                | Cleaning for <1 PPM Chlorine/Fluorine              | •  | •  | —  | —  |
| P4                | Calibrate at Line Pressure                         | •  | •  | —  | •  |
| P5                | Calibrate at Specific Temperature                  | •  | •  | •  | •  |
| P7 <sup>(5)</sup> | Improved Temperature Coefficient                   | •  | •  | •  | —  |
| P8 <sup>(6)</sup> | Calibrate to 0.1% Accuracy                         | •  | •  | •  | —  |
| Code              | Outputs  | DP | HP | GP | AP |
| V1 <sup>(7)</sup> | Reverse Output                                     | —  | —  | •  | —  |
| V2 <sup>(8)</sup> | 4–20 mV Test Signal                                | •  | •  | •  | •  |
| V3 <sup>(8)</sup> | 20–100 mV Test Signal                              | •  | •  | •  | •  |
| Z1 <sup>(9)</sup> | 4-wire, 0–20 mA Output                             | •  | •  | •  | •  |
| Z2 <sup>(9)</sup> | 4-wire, 0–16 mA Output                             | •  | •  | •  | •  |
| Z3 <sup>(9)</sup> | 4-wire, 0–10 mA Output                             | •  | •  | •  | •  |

Typical Model Number: 1151DP 4 S 52 B3 M1

- (1) Contains a Hastelloy spring that is wetted by the process; consult factory for Teflon O-ring without a spring.
- (2) Available with Output Code S only.
- (3) Hydrostatic testing for Range 0, 125% maximum working pressure.
- (4) Fluorolube<sup>®</sup> grease on wetted O-rings.
- (5) Not available on Range 10: limited to 1,500 psi on Range 9; not applicable with Output Code S.
- (6) Available only with stainless steel isolators and for span of 10 inH<sub>2</sub>O and greater; not applicable with Output Code S; available only with Output Codes E, G, L, or M; not available on AP or DR transmitters.
- (7) Reverse output option is not needed with smart electronics; configured via HART-based communicator.
- (8) Not available with Output Codes L or M.
- (9) Not available with Option Codes Mx, Vx, Ix, or Ex, or Output Codes G, L, M, or S.

TABLE 5-10. Model 1151LT Flange Mounted Liquid Level Transmitter.

| Model           | Product Description   |                 |                  |   |              |  |             |           |   |        |      |       |
|-----------------|---|-----------------|------------------|---|--------------|--|-------------|-----------|---|--------|------|-------|
| 1151LT          | Alphaline Flange-Mounted Liquid Level Transmitter                           |                 |                  |   |              |  |             |           |   |        |      |       |
| Code            | Range   |                 |                  |   |              |  |             |           |   |        |      |       |
| 4               | 0–25 to 0–150 inH <sub>2</sub> O (0–635 to 0–3,810 mmH <sub>2</sub> O)      |                 |                  | <table border="1"> <thead> <tr> <th colspan="2">Rangeability</th> </tr> <tr> <th>Output Code</th> <th>Min. Span</th> </tr> </thead> <tbody> <tr> <td>S</td> <td>URL/15</td> </tr> <tr> <td>E, G</td> <td>URL/6</td> </tr> </tbody> </table> | Rangeability |  | Output Code | Min. Span | S | URL/15 | E, G | URL/6 |
| Rangeability    |   |                 |                  |   |              |  |             |           |   |        |      |       |
| Output Code     | Min. Span   |                 |                  |   |              |  |             |           |   |        |      |       |
| S               | URL/15  |                 |                  |   |              |  |             |           |   |        |      |       |
| E, G            | URL/6   |                 |                  |   |              |  |             |           |   |        |      |       |
| 5               | 0–125 to 0–750 inH <sub>2</sub> O (0–3,175 to 0–19,050 mmH <sub>2</sub> O)  |                 |                  |   |              |  |             |           |   |        |      |       |
| 6               | 0–471 to 0–2,770 inH <sub>2</sub> O (0–11.96 to 0–70.36 mmH <sub>2</sub> O) |                 |                  |   |              |  |             |           |   |        |      |       |
| Code            | Output  |                 |                  |   |              |  |             |           |   |        |      |       |
| S               | 1151 Smart 4–20 mA dc Electronics (see PDS 00813-0100-4593)                 |                 |                  |   |              |  |             |           |   |        |      |       |
| E               | 4–20 mA dc, with Adjustable Damping   |                 |                  |   |              |  |             |           |   |        |      |       |
| G               | 10–50 mA dc, with Adjustable Damping  |                 |                  |   |              |  |             |           |   |        |      |       |
| Code            | Size  | Material        | Extension Length |   |              |  |             |           |   |        |      |       |
| G0              | 2 in./DN 50   | 316L SST        | Flush Mount Only | } When specifying these option codes, a lower housing must be selected from the flushing connection options Table 5-11.   |              |  |             |           |   |        |      |       |
| H0              | 2 in./DN 50   | Hastelloy C-276 | Flush Mount Only |   |              |  |             |           |   |        |      |       |
| J0              | 2 in./DN 50   | Tantalum        | Flush Mount Only |   |              |  |             |           |   |        |      |       |
| A0              | 3 in./DN 80   | 316L SST        | Flush Mount      | <div style="border: 1px solid black; padding: 5px;"> <p><b>NOTE</b><br/>Extension diameters are sized to fit Schedule 80 pipe. Consult factory for Schedule 40 pipe.</p> </div>   |              |  |             |           |   |        |      |       |
| A2              | 3 in./DN 80   | 316L SST        | 2 in./50 mm      |   |              |  |             |           |   |        |      |       |
| A4              | 3 in./DN 80   | 316L SST        | 4 in./100 mm     |   |              |  |             |           |   |        |      |       |
| A6              | 3 in./DN 80   | 316L SST        | 6 in./150 mm     |   |              |  |             |           |   |        |      |       |
| B0              | 4 in./DN 100  | 316L SST        | Flush Mount      |   |              |  |             |           |   |        |      |       |
| B2              | 4 in./DN 100  | 316L SST        | 2 in./50 mm      |   |              |  |             |           |   |        |      |       |
| B4              | 4 in./DN 100  | 316L SST        | 4 in./100 mm     |   |              |  |             |           |   |        |      |       |
| B6              | 4 in./DN 100  | 316L SST        | 6 in./150 mm     |   |              |  |             |           |   |        |      |       |
| C0              | 3 in./DN 80   | Hastelloy C-276 | Flush Mount      |   |              |  |             |           |   |        |      |       |
| C2              | 3 in./DN 80   | Hastelloy C-276 | 2 in./50 mm      |   |              |  |             |           |   |        |      |       |
| C4              | 3 in./DN 80   | Hastelloy C-276 | 4 in./100 mm     |   |              |  |             |           |   |        |      |       |
| C6              | 3 in./DN 80   | Hastelloy C-276 | 6 in./150 mm     |   |              |  |             |           |   |        |      |       |
| D0              | 4 in./DN 100  | Hastelloy C-276 | Flush Mount      |   |              |  |             |           |   |        |      |       |
| D2              | 4 in./DN 100  | Hastelloy C-276 | 2 in./50 mm      |   |              |  |             |           |   |        |      |       |
| D4              | 4 in./DN 100  | Hastelloy C-276 | 4 in./100 mm     |   |              |  |             |           |   |        |      |       |
| D6              | 4 in./DN 100  | Hastelloy C-276 | 6 in./150 mm     |   |              |  |             |           |   |        |      |       |
| E0              | 3 in./DN 80   | Tantalum        | Flush Mount Only |   |              |  |             |           |   |        |      |       |
| F0              | 4 in./DN 100  | Tantalum        | Flush Mount Only |   |              |  |             |           |   |        |      |       |
| MOUNTING FLANGE |   |                 |                  |   |              |  |             |           |   |        |      |       |
| Code            | Size  | Rating          | Material         | Applicable with these High Pressure Side Diaphragm Sizes  |              |  |             |           |   |        |      |       |
| M               | 2 in.   | Class 150       | ANSI             | 2 in./DN 50   |              |  |             |           |   |        |      |       |
| A               | 3 in.   | Class 150       |                  | CS  | 3 in./DN 80  |  |             |           |   |        |      |       |
| B               | 4 in.   | Class 150       |                  | CS  | 4 in./DN 100 |  |             |           |   |        |      |       |
| N               | 2 in.   | Class 300       |                  | CS  | 2 in./DN 50  |  |             |           |   |        |      |       |
| C               | 3 in.   | Class 300       |                  | CS  | 3 in./DN 80  |  |             |           |   |        |      |       |
| D               | 4 in.   | Class 300       |                  | CS  | 4 in./DN 100 |  |             |           |   |        |      |       |
| P               | 2 in.   | Class 600       |                  | CS  | 2 in./DN 50  |  |             |           |   |        |      |       |
| E               | 3 in.   | Class 600       |                  | CS  | 3 in./DN 80  |  |             |           |   |        |      |       |
| X               | 2 in.   | Class 150       |                  | SST   | 2 in./DN 50  |  |             |           |   |        |      |       |
| F               | 3 in.   | Class 150       |                  | SST   | 3 in./DN 80  |  |             |           |   |        |      |       |
| G               | 4 in.   | Class 150       |                  | SST   | 4 in./DN 100 |  |             |           |   |        |      |       |
| Y               | 2 in.   | Class 300       |                  | SST   | 2 in./DN 50  |  |             |           |   |        |      |       |
| H               | 3 in.   | Class 300       |                  | SST   | 3 in./DN 80  |  |             |           |   |        |      |       |
| J               | 4 in.   | Class 300       |                  | SST   | 4 in./DN 100 |  |             |           |   |        |      |       |
| Z               | 2 in.   | Class 600       |                  | SST   | 2 in./DN 50  |  |             |           |   |        |      |       |
| L               | 3 in.   | Class 600       |                  | SST   | 3 in./DN 80  |  |             |           |   |        |      |       |
| Q               | DN 50   | PN 10-40        | DIN              | 2 in./DN 50   |              |  |             |           |   |        |      |       |
| R               | DN 80   | PN 40           |                  | CS  | 3 in./DN 80  |  |             |           |   |        |      |       |
| S               | DN 100  | PN 40           |                  | CS  | 4 in./DN 100 |  |             |           |   |        |      |       |
| V               | DN 100  | PN 10/16        |                  | CS  | 4 in./DN 100 |  |             |           |   |        |      |       |
| K               | DN 50   | PN 10-40        |                  | SST   | 2 in./DN 50  |  |             |           |   |        |      |       |
| T               | DN 80   | PN 40           |                  | SST   | 3 in./DN 80  |  |             |           |   |        |      |       |
| U               | DN 100  | PN 40           |                  | SST   | 4 in./DN 100 |  |             |           |   |        |      |       |
| W               | DN 100  | PN 10/16        |                  | SST   | 4 in./DN 100 |  |             |           |   |        |      |       |

TABLE 5-10. (continued).

| SENSOR MODULE AND LOW-SIDE MATERIALS OF CONSTRUCTION |                                 |                        |                                |                     |
|--|---------------------------------|------------------------|--------------------------------|---------------------|
| Code   | Low-Side Flange and Adapter     | Drain/Vent Valves      | Low-Side Isolator Diaphragm    | Low-Side Fluid Fill |
| 52   | Nickel-plated CS                | 316 SST                | 316L SST                       | Silicone            |
| 12   | Cadmium-plated CS               | 316 SST                | 316L SST                       | Silicone            |
| 55   | Nickel-plated CS                | 316 SST                | Tantalum                       | Silicone            |
| 22   | 316 SST                         | 316 SST                | 316L SST                       | Silicone            |
| 23   | 316 SST                         | 316 SST                | <i>Hastelloy C-276</i>         | Silicone            |
| 25   | 316 SST                         | 316 SST                | Tantalum                       | Silicone            |
| 33   | <i>Hastelloy C</i>              | <i>Hastelloy C-276</i> | <i>Hastelloy C-276</i>         | Silicone            |
| 35   | <i>Hastelloy C</i>              | <i>Hastelloy C-276</i> | Tantalum                       | Silicone            |
| 1A   | Cadmium-plated CS               | 316 SST                | 316L SST                       | Inert               |
| 5D   | Nickel-plated CS                | 316 SST                | Tantalum                       | Inert               |
| 2A   | 316 SST                         | 316 SST                | 316L SST                       | Inert               |
| 2B   | 316 SST                         | 316 SST                | <i>Hastelloy C-276</i>         | Inert               |
| 2D   | 316 SST                         | 316 SST                | Tantalum                       | Inert               |
| 3B   | <i>Hastelloy C</i>              | <i>Hastelloy C-276</i> | <i>Hastelloy C-276</i>         | Inert               |
| 3D   | <i>Hastelloy C</i>              | <i>Hastelloy C-276</i> | Tantalum                       | Inert               |
| Code   | Process Fill—High Pressure Side |                        | Temperature Limits             |                     |
| A  | <i>Syltherm</i> XLT             |                        | -100 to 300 °F (-73 to 135 °C) |                     |
| C  | <i>D. C. Silicone</i> 704       |                        | 60 to 400 °F (15 to 205 °C)    |                     |
| D  | <i>D. C. Silicone</i> 200       |                        | -40 to 400 °F (-40 to 205 °C)  |                     |
| F  | Inert                           |                        | -50 to 350 °F (-45 to 177 °C)  |                     |
| G  | Glycerin and Water              |                        | 0 to 200 °F (-17 to 93 °C)     |                     |
| N  | <i>Neobee M-20</i>              |                        | 0 to 400 °F (-17 to 205 °C)    |                     |
| P  | Propylene Glycol and Water      |                        | 0 to 200 °F (-17 to 93 °C)     |                     |
| S  | <i>Syltherm</i> 800             |                        | -50 to 400 °F (-45 to 205 °C)  |                     |

TABLE 5-10. (continued).

| Code              | Options (see complete approvals descriptions)   |
|-------------------|---|
| S1 <sup>(1)</sup> | One Remote Seal Selected from PDS 00813-0100-4016   |
|                   | <b>METERS</b>   |
| M1 <sup>(2)</sup> | Linear Meter, 0–100% Scale  |
| M3 <sup>(2)</sup> | Special Scale Meter, Specify Range  |
| M4 <sup>(2)</sup> | LCD Meter, 0–100%   |
| M7 <sup>(2)</sup> | LCD Meter, Linear, Special Configuration  |
|                   | <b>HARZARDOUS LOCATIONS CERTIFICATIONS</b>  |
| E6                | Canadian Standards Association (CSA) Explosion-Proof Approval   |
| I5 <sup>(3)</sup> | Factory Mutual (FM) Non-incendive and Intrinsic Safety Approval   |
| K5                | Factory Mutual (FM) Explosion-Proof and Intrinsic Safety Combination  |
| I6 <sup>(1)</sup> | Canadian Standards Association (CSA) Intrinsic Safety Approval  |
| C5 <sup>(4)</sup> | Industry and Science Canada (ISC) Approval (Available in Canada Only)   |
| C6 <sup>(1)</sup> | Combination of I6 and E6; CSA Explosion-Proof and Intrinsic Safety Approval<br>(Requires 42.4 V dc max. power supply) |
| K6                | CSA/CENELEC Explosion-Proof and Intrinsic Safety Approval   |
| E4                | Japanese Industrial Standards (JIS) Flameproof Certification  |
| E7                | Standards Association of Australia (SAA) Flameproof Certification   |
| E8                | CESI/CENELEC Flameproof Certification   |
| I1 <sup>(5)</sup> | BASEEFA Intrinsic Safety Certification  |
| I7 <sup>(1)</sup> | Standards Association of Australia (SAA) Intrinsic Safety Certification   |
| I8 <sup>(6)</sup> | CESI/CENELEC Flameproof Certification   |
| N1 <sup>(7)</sup> | BASEEFA Type N Certification  |
| N7                | Standards Association of Australia (SAA) Nonincendive Safety Approval   |
| IC <sup>(3)</sup> | Schweizerischer Elektrotechnischer Verein (SEV) Intrinsic Safety Certification  |
|                   | <b>OTHER OPTIONS</b>  |
| W5                | Copper O-ring for Vacuum Service (Nonwetted)  |
| Q4                | Calibration Data Sheet  |
| Q8 <sup>(8)</sup> | Material Traceability per EN 10204 3.1B   |
| V1                | Reverse Output  |
| V2                | 4–20 mV Test Signal   |
| V3                | 20–100 mV Test Signal   |
| Z1 <sup>(9)</sup> | 4-wire, 0–20 mA Output  |
| Z2 <sup>(9)</sup> | 4-wire, 0–16 mA Output  |
| Z3 <sup>(9)</sup> | 4-wire, 0–10 mA Output  |
| F_                | Select One Code from Flushing Connections Lower Housing Option Table 5-11.  |

**NOTE**  
FM explosion-proof approval is standard.

TABLE 5-11. Flushing Connections Lower Housing Options.      • available    – not available

| Code              | Flushing Connection Ring Material (Lower Housing) | Flushing Connections | Size     | Diaphragm Size |       |       |
|-------------------|---|----------------------|----------|----------------|-------|-------|
|                   |   |                      |          | 2-in.          | 3-in. | 4-in. |
| F1                | SST   | 1                    | ¼-18 NPT | •              | •     | •     |
| F2                | SST   | 2                    | ¼-18 NPT | •              | •     | •     |
| F3 <sup>(1)</sup> | Hastelloy C-276                                   | 1                    | ¼-18 NPT | •              | •     | •     |
| F4 <sup>(1)</sup> | Hastelloy C-276                                   | 2                    | ¼-18 NPT | •              | •     | •     |
| FA                | SST   | 0                    | —        | •              | —     | —     |
| FC <sup>(2)</sup> | Hastelloy C-276                                   | 0                    | —        | •              | —     | —     |
| F7                | SST   | 1                    | ½-14 NPT | •              | •     | •     |
| F8                | SST   | 2                    | ½-14 NPT | •              | •     | •     |
| F9                | Hastelloy C-276                                   | 1                    | ½-14 NPT | •              | •     | •     |
| F0                | Hastelloy C-276                                   | 2                    | ½-14 NPT | •              | •     | •     |

(1) Not available with high pressure side Option Codes A0, B0, and G0.  
 (2) Not available with high pressure side Option Code G0.

Typical Model Number: 1151LT 4 S A0 A 52 D F1

- (1) For welded capillary assemblies, order sensor module and low-side materials of construction Option Code 22 (refer to PDS 00813-0100-4016 for more information).
- (2) Not available with Option Codes Zx, V2, or V3.
- (3) Not available with Output Code G or Option Code Zx.
- (4) Not available with Option Codes M1–M9.
- (5) Not available with Output Codes G, J, L, M, or Option Code Zx.
- (6) Not available with Output Codes G, J, L, M, S, or Option Code Zx.
- (7) Not available with Output Codes G, L, M, or Option Code Zx.
- (8) Available for the diaphragm, upper housing, flange, adapter, extension, and lower housing.
- (9) Not available with Option Codes Mx, Vx, Ix, or Ex, or Output Codes G, L, M, or S.

**General Notes**

The listed prices are dimensionless. Apply the appropriate multiplication factor to calculate the price in a specific currency. All prices are F.O.B. our plant at Chanhassen, Minnesota. The prices are exclusive of all sales and use taxes.

Minimum order is 600 (dimensionless price).

**Tagging**

The transmitter will be tagged, at no charge, in accordance with customer requirements. All tags are stainless steel. The standard tag is wired to the transmitter. Tag character height is 0.125 in. (0.318 cm). A permanently attached tag is available upon request.

**Calibration**

Transmitters are factory calibrated to customer's specified range. If calibration is not specified, the transmitters are calibrated at maximum range. Calibration is performed at ambient temperature and pressure.

**Standard Accessories**

All models are shipped with flange adapters, drain/vent valves, and one instruction manual per shipment.

**Optional Three-valve Manifolds**

**Part No. 01166-0073-0001:**

3-valve manifold, carbon steel for DP (Ranges 6–9), HP (Ranges 6–7).  
(Anderson, Greenwood & Co., M4AVIC-TR-68).

**Part No. 01151-0150-0002:**

3-valve manifold, 316 SST with carbon steel bolts for  
DP (Ranges 6–9), HP (Ranges 6–7).  
(Anderson, Greenwood & Co., M4AVIC-TR-68).

## Parts List

Item numbers are references to figure callouts (page 5-26).

TABLE 5-12. Model 1151 DP, HP, GP, and AP Alkaline Pressure Transmitters.

| <b>Electronics – One spare part recommended for every 25 transmitters.</b>                  |                 |                    |
|---|-----------------|--------------------|
| <b>Part Description</b>   | <b>Item No.</b> | <b>Part Number</b> |
| <b>S Smart Output Code</b>  |                 |                    |
| Smart Retrofit Kit <sup>(1)</sup>   |                 | 01151-0935-0001    |
| Smart Transmitter Electronics <sup>(2)</sup>  | 24              | 01151-0934-0204    |
| Board Spacer Kit (pkg of 12)  | 25              | 01151-0813-0001    |
| Terminal Eyelet Kit (pkg of 12)   |                 | 01151-0814-0001    |
| Standoff Kit (pkg of 12)  |                 | 01151-0815-0001    |
| Cover <sup>(2)</sup>  |                 | 01151-1045-0001    |
| Cover O-ring (pkg of 12)  |                 | 01151-0033-0003    |
| <b>Sensor Modules (Silicone Fill)–One spare part recommended for every 50 transmitters.</b> |                 |                    |
| <b>Part Description</b>   | <b>Item No.</b> | <b>Part Number</b> |
| <b>Range 3 DP, GP (30 in H<sub>2</sub>O)</b>  | 19              |                    |
| 316L SST  |                 | 01151-0011-0032    |
| <i>Hastelloy C-276</i>  |                 | 01151-0011-0033    |
| <i>Monel</i>  |                 | 01151-0011-0034    |
| Tantalum  |                 | 01151-0011-0035    |
| Gold-plated <i>Monel</i>  |                 | 01151-0011-0036    |
| <b>Range 4 DP, GP (150 in H<sub>2</sub>O)</b>   | 19              |                    |
| 316L SST  |                 | 01151-0011-0042    |
| <i>Hastelloy C-276</i>  |                 | 01151-0011-0043    |
| <i>Monel</i>  |                 | 01151-0011-0044    |
| Tantalum  |                 | 01151-0011-0045    |
| Gold-plated <i>Monel</i>  |                 | 01151-0011-0046    |
| <b>Range 4 HP (150 in H<sub>2</sub>O)</b>   | 19              |                    |
| 316L SST  |                 | 01151-0112-0042    |
| <i>Hastelloy C-276</i>  |                 | 01151-0112-0043    |
| <i>Monel</i>  |                 | 01151-0112-0044    |
| <b>Range 4 AP (11 in H<sub>2</sub>A)</b>  | 19              |                    |
| 316L SST  |                 | 01151-0054-0042    |
| <i>Hastelloy C-276</i>  |                 | 01151-0054-0043    |
| <i>Monel</i>  |                 | 01151-0054-0044    |

(1) Kit contains enough parts for one transmitter and includes the smart transmitter electronics, board spacers, terminal eyelets, standoffs, cover, and cover O-ring.

(2) Package contains quantity required for one transmitter.

**Rosemount Model 1151 Smart Pressure Transmitters**

TABLE 5-12. (continued).

| <b>Sensor Modules (Silicone Fill)—One spare part recommended for every 50 transmitters.</b>   |                 |   |
|---|-----------------|---|
| <b>Part Description</b>   | <b>Item No.</b> | <b>Part Number</b>  |
| <b>Range 5 DP, GP (750 in H<sub>2</sub>O)</b><br>316L SST<br><i>Hastelloy C-276</i><br><i>Monel</i><br>Tantalum<br>Gold-plated <i>Monel</i> | 19              | 01151-0011-0052<br>01151-0011-0053<br>01151-0011-0054<br>01151-0011-0055<br>01151-0011-0056 |
| <b>Range 5 HP (750 in H<sub>2</sub>O)</b><br>316L SST<br><i>Hastelloy C-276</i><br><i>Monel</i>   | 19              | 01151-0112-0052<br>01151-0112-0053<br>01151-0112-0054                                       |
| <b>Range 5 AP (55 in H<sub>g</sub>A)</b><br>316L SST<br><i>Hastelloy C-276</i><br><i>Monel</i>  | 19              | 01151-0054-0052<br>01151-0054-0053<br>01151-0054-0054                                       |
| <b>Range 6 DP (100 psid)</b><br>316L SST<br><i>Hastelloy C-276</i><br><i>Monel</i><br>Tantalum<br>Gold-plated <i>Monel</i>                  | 19              | 01151-0041-0062<br>01151-0041-0063<br>01151-0041-0064<br>01151-0041-0065<br>01151-0041-0066 |
| <b>Range 6 GP (100 psig)</b><br>316L SST<br><i>Hastelloy C-276</i><br><i>Monel</i><br>Tantalum<br>Gold-plated <i>Monel</i>                  | 19              | 01151-0041-0162<br>01151-0041-0163<br>01151-0041-0164<br>01151-0041-0165<br>01151-0041-0166 |
| <b>Range 6 HP (100 psid)</b><br>316L SST<br><i>Hastelloy C-276</i><br><i>Monel</i>  | 19              | 01151-0112-0062<br>01151-0112-0063<br>01151-0112-0064                                       |
| <b>Range 6 AP (100 psia)</b><br>316L SST<br><i>Hastelloy C-276</i><br><i>Monel</i>  | 19              | 01151-0054-0062<br>01151-0054-0063<br>01151-0054-0064                                       |
| <b>Range 7 DP (300 psid)</b><br>316L SST<br><i>Hastelloy C-276</i><br><i>Monel</i><br>Tantalum<br>Gold-plated <i>Monel</i>                  | 19              | 01151-0041-0072<br>01151-0041-0073<br>01151-0041-0074<br>01151-0041-0075<br>01151-0041-0076 |
| <b>Range 7 GP (300 psig)</b><br>316L SST<br><i>Hastelloy C-276</i><br><i>Monel</i><br>Tantalum<br>Gold-plated <i>Monel</i>                  | 19              | 01151-0041-0172<br>01151-0041-0173<br>01151-0041-0174<br>01151-0041-0175<br>01151-0041-0176 |
| <b>Range 7 HP (300 psid)</b><br>316L SST<br><i>Hastelloy C-276</i><br><i>Monel</i>  | 19              | 01151-0112-0072<br>01151-0112-0073<br>01151-0112-0074                                       |
| <b>Range 7 AP (300 psia)</b><br>316L SST<br><i>Hastelloy C-276</i><br><i>Monel</i>  | 19              | 01151-0054-0072<br>01151-0054-0073<br>01151-0054-0074                                       |
| <b>Range 8 DP (1,000 psid)</b><br>316L SST<br><i>Hastelloy C-276</i><br><i>Monel</i><br>Tantalum<br>Gold-plated <i>Monel</i>                | 19              | 01151-0041-0082<br>01151-0041-0083<br>01151-0041-0084<br>01151-0041-0085<br>01151-0041-0086 |



TABLE 5-12. (continued).

| <b>Sensor Modules (Silicone Fill)—One spare part recommended for every 50 transmitters.</b>   |                 |   |
|---|-----------------|---|
| <b>Part Description</b>   | <b>Item No.</b> | <b>Part Number</b>  |
| <b>Range 8 GP (1,000 psig)</b><br>316L SST<br><i>Hastelloy C-276</i><br><i>Monel</i><br>Tantalum<br>Gold-plated <i>Monel</i>                | 19              | 01151-0041-0182<br>01151-0041-0183<br>01151-0041-0184<br>01151-0041-0185<br>01151-0041-0186 |
| <b>Range 8 AP (1,000 psia)</b><br>316L SST<br><i>Hastelloy C-276</i><br><i>Monel</i>  | 19              | 01151-0054-0082<br>01151-0054-0083<br>01151-0054-0084                                       |
| <b>Range 9 GP (3,000 psig)</b><br>316L SST<br><i>Hastelloy C-276</i><br><i>Monel</i>  | 19              | 01151-0112-0092<br>01151-0112-0093<br>01151-0112-0094                                       |
| <b>Range 10 GP (6,000 psig)</b><br>316L SST<br><i>Hastelloy C-276</i><br><i>Monel</i>   | 19              | 01151-0112-0002<br>01151-0112-0003<br>01151-0112-0004                                       |
| <b>Sensor Modules (Inert Fill)—One spare part recommended for every 50 transmitters.</b>  |                 |   |
| <b>Part Description</b>   | <b>Item No.</b> | <b>Part Number</b>  |
| <b>Range 3 DP, GP (30 in H<sub>2</sub>O)</b><br>316L SST<br><i>Hastelloy C-276</i><br><i>Monel</i><br>Tantalum<br>Gold-plated <i>Monel</i>  | 19              | 01151-0230-0032<br>01151-0230-0033<br>01151-0230-0034<br>01151-0230-0035<br>01151-0230-0036 |
| <b>Range 4 DP, GP (150 in H<sub>2</sub>O)</b><br>316L SST<br><i>Hastelloy C-276</i><br><i>Monel</i><br>Tantalum<br>Gold-plated <i>Monel</i> | 19              | 01151-0230-0042<br>01151-0230-0043<br>01151-0230-0044<br>01151-0230-0045<br>01151-0230-0046 |
| <b>Range 5 DP, GP (750 in H<sub>2</sub>O)</b><br>316L SST<br><i>Hastelloy C-276</i><br><i>Monel</i><br>Tantalum<br>Gold-plated <i>Monel</i> | 19              | 01151-0230-0052<br>01151-0230-0053<br>01151-0230-0054<br>01151-0230-0055<br>01151-0230-0056 |
| <b>Range 6 DP (100 psid)</b><br>316L SST<br><i>Hastelloy C-276</i><br><i>Monel</i><br>Tantalum  | 19              | 01151-0230-0062<br>01151-0230-0063<br>01151-0230-0064<br>01151-0230-0065                    |
| <b>Range 6 GP (100 psig)</b><br>316L SST<br><i>Hastelloy C-276</i><br><i>Monel</i><br>Tantalum  | 19              | 01151-0230-0162<br>01151-0230-0163<br>01151-0230-0164<br>01151-0230-0165                    |
| <b>Range 7 DP (300 psid)</b><br>316L SST<br><i>Hastelloy C-276</i><br><i>Monel</i><br>Tantalum  | 19              | 01151-0230-0072<br>01151-0230-0073<br>01151-0230-0074<br>01151-0230-0075                    |

TABLE 5-12. (continued).

| <b>Sensor Modules (Inert Fill)–One spare part recommended for every 50 transmitters.</b>  |                 |   |
|---|-----------------|---|
| <b>Part Description</b>   | <b>Item No.</b> | <b>Part Number</b>  |
| <b>Range 7 GP (300 psig)</b><br>316L SST<br><i>Hastelloy C-276</i><br><i>Monel</i><br>Tantalum  | 19              | 01151-0230-0172<br>01151-0230-0173<br>01151-0230-0174<br>01151-0230-0175                    |
| <b>Range 8 DP (1,000 in psid)</b><br>316L SST<br><i>Hastelloy C-276</i><br><i>Monel</i><br>Tantalum   | 19              | 01151-0230-0082<br>01151-0230-0083<br>01151-0230-0084<br>01151-0230-0085                    |
| <b>Range 8 GP (1,000 in psig)</b><br>316L SST<br><i>Hastelloy C-276</i><br><i>Monel</i><br>Tantalum   | 19              | 01151-0230-0182<br>01151-0230-0183<br>01151-0230-0184<br>01151-0230-0185                    |
| <b>Housings, Covers, Flanges, And Valves – One spare part recommended for every 25 transmitters.</b>  |                 |   |
| <b>Part Description</b>   | <b>Item No.</b> | <b>Part Number</b>  |
| <b>Electronics Housing</b><br><b>Electronics Housing for R1 Option without Terminal Block</b><br><b>Transient Terminal Block Assembly (Optional R1)</b>           | 7               | 01151-0060-0007<br>01151-2594-0001<br>01151-2591-0003                                       |
| <b>Electronics Cover</b>  | 1               | 01151-1045-0001   |
| <b>Process Flange</b><br>Nickel-plated Carbon Steel<br>Cadmium-plated Carbon Steel<br>316 SST<br><i>Hastelloy C-276</i><br><i>Monel</i>                           | 17              | 01151-0236-0005<br>01151-0236-0001<br>01151-0213-0002<br>01151-0213-0004<br>01151-0213-0003 |
| <b>Process Flange for Side Drain/Vent Valve</b><br>Nickel-plated Carbon Steel<br>Cadmium-plated Carbon Steel<br>316 SST<br><i>Hastelloy C-276</i><br><i>Monel</i> |                 | 01151-0236-0015<br>01151-0236-0011<br>01151-0213-0012<br>01151-0213-0014<br>01151-0213-0013 |
| <b>Blank Flange</b><br>Cadmium-plated Carbon Steel  | 23              | 90043-0046-0001   |
| <b>Flange Adapter</b><br>Nickel-plated Carbon Steel<br>Cadmium-plated Carbon Steel<br>316 SST<br><i>Hastelloy C-276</i><br><i>Monel</i>                           | 21              | 01151-0211-0005<br>90001-0033-0001<br>01151-0211-0002<br>01151-0211-0004<br>01151-0211-0003 |
| DP and HP Valve Stem and Seat, 316 SST <sup>(1)</sup>   | 14,15           | 01151-0028-0022   |
| GP and AP Valve Stem and Seat, 316 SST <sup>(1)</sup>   | 14,15           | 01151-0028-0012   |
| DP and HP Valve Stem and Seat, 316 SST, <i>Hastelloy C</i> <sup>(1)</sup>   | 14,15           | 01151-0028-0023   |
| GP and AP Valve Stem and Seat, 316 SST, <i>Hastelloy C</i> <sup>(1)</sup>   | 14,15           | 01151-0028-0013   |
| DP and HP Valve Stem and Seat, 316 SST, <i>Monel</i> <sup>(1)</sup>   | 14,15           | 01151-0028-0024   |
| GP and AP Valve Stem and Seat, 316 SST, <i>Monel</i> <sup>(1)</sup>   | 14,15           | 01151-0028-0014   |
| Plug, 316 SST (used with side drain/vent)   |                 | C50246-0002   |
| Plug, <i>Hastelloy C</i> (used with side drain/vent)  |                 | 01151-0063-0001   |
| Plug, <i>Monel</i> (used with side drain/vent)  |                 | 01151-0063-0002   |

(1) Package contains quantity required for one transmitter.

TABLE 5-12. (continued).

| Hardware—One spare part recommended for every 50 transmitters.             |          |                 |
|--|----------|-----------------|
| Part Description   | Item No. | Part Number     |
| <b>Adjustment Kit</b>  |          | 01151-0029-0001 |
| Adjustment Screw   | 10       |                 |
| O-ring for Adjustment Screw  | 11       |                 |
| Retaining Ring   | 12       |                 |
| O-ring for Adjustment Screw (pkg of 12)                                    | 11       | 01151-0032-0001 |
| O-ring for Electronics Cover (pkg of 12)                                   | 2        | 01151-0033-0003 |
| O-ring for Process Flange, <i>Viton</i> (pkg of 12)                        | 18       | 01151-0034-0020 |
| O-ring for Process Flange, <i>Viton</i> and Backup Ring (pkg of 4)         | 18       | 01151-0034-0014 |
| O-ring for Process Flange, Buna-N (pkg of 12)                              | 18       | 01151-0034-0002 |
| O-ring for Process Flange, Buna-N and Backup Ring (pkg of 4)               | 18       | 01151-0034-0016 |
| O-ring for Process Flange, Ethylene-propylene (pkg of 12)                  | 18       | 01151-0034-0004 |
| O-ring for Process Flange, Ethylene-propylene and Backup Ring (pkg of 4)   | 18       | 01151-0034-0015 |
| O-ring for Process Flange, <i>Aflas</i> (pkg of 4) <sup>(1)</sup>          | 18       | 01151-0034-0019 |
| O-ring for Flange, <i>Teflon</i> with <i>Hastelloy C</i> Spring (pkg of 4) | 18       | 01151-0034-0021 |
| O-ring for Flange Adapter, <i>Viton</i> (pkg of 12)                        | 20       | 01151-0035-0009 |
| O-ring for Flange Adapter, Buna-N (pkg of 12)                              | 20       | 01151-0035-0002 |
| O-ring for Flange Adapter, Ethylene-propylene (pkg of 12)                  | 20       | 01151-0035-0004 |
| O-ring for Flange Adapter, <i>Aflas</i> (pkg of 12) <sup>(2)</sup>         | 20       | 01151-0035-0008 |
| O-ring for Flange Adapter Process, <i>Teflon</i> (pkg of 12)               | 20       | 01151-0035-0003 |

(1) Kit contains enough parts for two differential or four gage/absolute transmitters. Backup rings are included.

(2) Part number is for package of 12 O-rings—only two required per transmitter.

TABLE 5-12. (continued).

| <b>Hardware (continued)—One spare part recommended for every 50 transmitters.</b>  |                  |  |
|--|------------------|--|
| <b>Part Description</b>  | <b>Item No.</b>  | <b>Part Number</b>   |
| <b>Electronics Assembly Hardware<sup>(1)</sup></b><br>Standoff<br>Standoff<br>Screw<br>Screw<br>Locknut  | 8<br>5<br>9<br>3 | 01151-0030-0001  |
| <b>DP and HP Flange Kits, Carbon Steel<sup>(1)</sup></b><br>Bolt for Flange Adapter<br>Bolt for Process Flange<br>Nut for Process Flange   | 22<br>13<br>16   | 01151-0031-0001<br>(DP & HP Ranges 3–7)<br>or<br>01151-0031-0034<br>(DP Range 8)   |
| <b>GP and AP Flange Kits, Carbon Steel<sup>(1)</sup></b><br>Bolt for Flange Adapter, Carbon Steel<br>Bolt for Process Flange, Carbon Steel<br>Nut for Process Flange, Carbon Steel | 22<br>13<br>16   | 01151-0031-0002<br>(AP Ranges 4–7,<br>GP Ranges 3–7)<br>or<br>01151-0031-0035<br>(AP & GP Range 8)<br>or<br>01151-0031-0003 (GP<br>Range 9)<br>or<br>01151-0031-0019<br>(GP Range 0) |
| <b>DP and HP Flange Kits, 316 SST<sup>(1)</sup></b><br>Bolt for Flange Adapter<br>Bolt for Process Flange<br>Nut for Process Flange  | 22<br>13<br>16   | 01151-0031-0023<br>(DP & HP Ranges 3–7)<br>or<br>01151-0031-0038<br>(DP Range 8)   |
| <b>GP and AP Flange Kits, 316 SST<sup>(1)</sup></b><br>Bolt for Flange Adapter, 316 SST<br>Bolt for Process Flange, 316 SST<br>Nut for Process Flange, 316 SST                     | 22<br>13<br>16   | 01151-0031-0024<br>(AP Ranges 4–7,<br>GP Ranges 3–7)<br>or<br>01151-0031-0039<br>(AP & GP Range 8)<br>or<br>01151-0031-0025 (GP<br>Range 9)<br>or<br>01151-0031-0026<br>(GP Range 0) |
| <b>DP and HP Flange Kits, ANSI 193-B7<sup>(1)</sup></b><br>Bolt for Flange Adapter<br>Bolt for Process Flange<br>Nut for Process Flange  | 22<br>13<br>16   | 01151-0031-0012<br>(DP & HP Ranges 3–7)<br>or<br>01151-0031-0036<br>(DP Range 8)   |
| <b>GP and AP Flange Kits, ANSI 193-B7<sup>(1)</sup></b><br>Bolt for Flange Adapter, ANSI 193-B7<br>Bolt for Process Flange, ANSI 193-B7<br>Nut for Process Flange, ANSI 193-B7     | 22<br>13<br>16   | 01151-0031-0013<br>(AP Ranges 4–7,<br>GP Ranges 3–7)<br>or<br>01151-0031-0037<br>(AP & GP Range 8)<br>or<br>01151-0031-0014 (GP<br>Range 9)<br>or<br>01151-0031-0022<br>(GP Range 0) |

(1) Package contains quantity required for one transmitter.

TABLE 5-12. (continued).

| Indicating Meters (Select approved meter kits for use in intrinsically safe and/or Type N installations) |          |                    |
|--|----------|--------------------|
| Part Description   | Item No. | Part Number        |
| Analog Meter Kit, 4–20 mA dc, Linear Scale <sup>(1)</sup>  | NA       | 01151-1046-0007    |
| Analog Meter Kit, 4–20 mA dc, Square Root, 0-100% Flow   |          | 01151-1046-0009    |
| Analog Meter Kit, 10–50 mA dc, Linear Scale <sup>(1)</sup>   |          | 01151-1046-0011    |
| Analog Meter Kit, 10–50 mA dc, Square Root, 0–100% Flow  |          | 01151-1046-0013    |
| <b>Approved</b> Analog Meter Kit, 4–20 mA dc, Linear Scale <sup>(1)</sup>                                |          | 01151-2615-0007    |
| <b>Approved</b> Analog Meter Kit, 4–20 mA dc, Square Root, 0-100% Flow                                   |          | 01151-2615-0009    |
| <b>Approved</b> Analog Meter Kit, 10–50 mA dc, Linear Scale <sup>(1)</sup>                               |          | 01151-2615-0011    |
| <b>Approved</b> Analog Meter Kit, 10–50 mA dc, Square Root, 0–100% Flow                                  |          | 01151-2615-0013    |
| LCD Meter Kit, Linear, 0–100% Flow   |          | 01151-1046-0019    |
| LCD Meter Kit, Square Root, 0–100% Flow  |          | 01151-1046-0021    |
| Analog Meter, 4–20 mA dc, Linear Scale   |          | 01151-0687-0004    |
| Analog Meter, 4–20 mA dc, Square Root, 0–100% Flow   |          | 01151-0687-0005    |
| Analog Meter, 4–20 mA dc, Square Root, 0–10 √  |          | 01151-0687-0008    |
| Analog Meter, 10–50 mA dc, Linear Scale  |          | 01151-0687-0006    |
| Analog Meter, 10–50 mA dc, Square Root, 0–100% Flow  |          | 01151-0687-0007    |
| Analog Meter, 10–50 mA dc, Square Root, 0–10 √   |          | 01151-0687-0009    |
| <b>Approved</b> Analog Meter, 4–20 mA dc, Linear Scale   |          | 01151-2614-0004    |
| <b>Approved</b> Analog Meter, 4–20 mA dc, Square Root, 0–100% Flow                                       |          | 01151-2614-0005    |
| <b>Approved</b> Analog Meter, 4–20 mA dc, Square Root, 0–10 √  |          | 01151-2614-0008    |
| <b>Approved</b> Analog Meter, 10–50 mA dc, Linear Scale  |          | 01151-2614-0006    |
| <b>Approved</b> Analog Meter, 10–50 mA dc, Square Root, 0–100% Flow                                      |          | 01151-2614-0007    |
| <b>Approved</b> Analog Meter, 10–50 mA dc, Square Root, 0–10 √   |          | 01151-2614-0009    |
| Special Scale for Analog Meter   |          | See note (1) below |
| LCD Meter, Linear, 0–100%  |          | 01151-1300-1000    |
| LCD Meter, Square Root, 0–100% Flow  |          | 01151-1300-1001    |
| LCD Meter, Special Configuration <sup>(2)</sup>  |          | 01151-1351-1000    |
| LCD Meter Engineering Unit Labels  |          | 01151-1351-1001    |
| Mounting Hardware and Cover Assembly Kit   |          | 01151-1046-0005    |
| Mounting Hardware Kit  |          | 01151-1046-0006    |
| Cover Assembly Kit   |          | 01151-1047-0001    |
| O-ring for Cover (pkg of 12)   |          | 01151-0033-0003    |
| Mounting Brackets  |          |                    |
| Part Description   | Item No. | Part Number        |
| B1—Right-angle Bracket for 2-in. Pipe Mounting   | NA       | 01151-0036-0001    |
| B2—Right-angle Bracket for Panel Mounting  |          | 01151-0036-0004    |
| B3—Flat Bracket for 2-in. Pipe Mounting  |          | 01151-0036-0005    |
| B4—Bracket for 2-in. Pipe with Series 300 SST Bolts  |          | 01151-0036-0003    |
| B5—Bracket for Panel with Series 300 SST Bolts   |          | 01151-0036-0006    |
| B6—Flat Bracket for 2-in. Pipe with Series 300 SST Bolts   |          | 01151-0036-0007    |
| B7—316 SST B1 Bracket with SST Bolts   |          | 01151-0036-0021    |
| B9—316 SST B3 Bracket with SST Bolts   |          | 01151-0036-0022    |

(1) Meter kit includes meter, mounting hardware, and cover assembly. For meters with special scaling, order the appropriate meter and specify the scale desired. Mounting hardware and cover assembly must be ordered separately.

(2) To order a meter with a special configuration, order the appropriate meter and indicate configuration desired. To order a special configuration LCD meter kit, order the meter, and the mounting hardware and cover assembly kit separately.

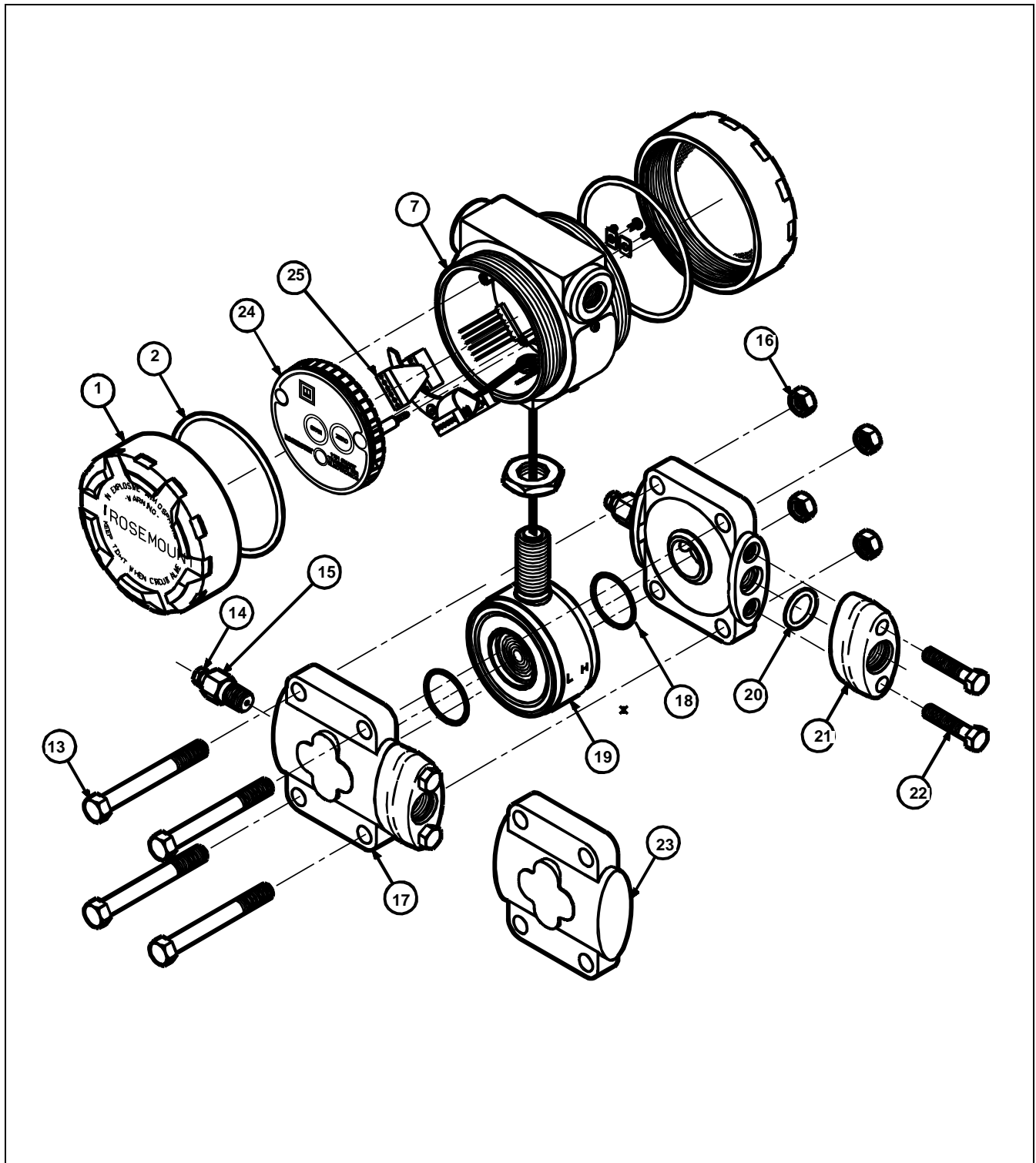


FIGURE 5-1. Model 1151 Smart Pressure Transmitter Exploded View.

1151-1151A27B

## Parts List

Item numbers are references to figure callouts (page 5-29).

TABLE 5-13. Model 1151LT Flange-Mounted Liquid Level Pressure Transmitter.

| Part Description  | Item No.             | Part Number  | Spares Category <sup>(1)</sup> |
|---|----------------------|--|--------------------------------|
| Diaphragm and Sensor Module Assembly  | 13                   | See Note Below   | B                              |
| <b>Flange Adapter Union</b><br>Cadmium-plated Carbon Steel<br>316 SST<br><i>Hastelloy C</i>   | 21                   | 90001-0033-0001<br>01151-0211-0002<br>01151-0211-0004                    |                                |
| Valve Stem and Seat, 316 SST<br>Plug, 316 SST (used with side drain/vent)   | 18, 19               | 01151-0028-0012<br>C50246-0002   | A                              |
| Valve Stem and Seat, <i>Hastelloy C</i><br>Plug, <i>Hastelloy C</i> (used with side drain/vent)   | 18, 19               | 01151-0028-0013<br>C50246-0202   | A                              |
| <b>Bolt for Flange Adaptor</b><br>Cadmium-plated Carbon Steel<br>316 SST<br>ANSI 193-B7   | 20<br>20<br>20       | 01151-0031-0002<br>01151-0031-0024<br>01151-0031-0013                    |                                |
| <b>O-ring for Flange Adapter</b><br><i>Viton</i> (pkg of 12)<br>Buna-N (pkg of 12)<br><i>Aflas</i> (pkg of 4)<br>Ethylene-Prop. (pkg of 12) | 22<br>22<br>22<br>22 | 01151-0035-0009<br>01151-0035-0002<br>01151-0035-0008<br>01151-0035-0004 |                                |
| SMART OUTPUT CODE – See next page for details   | —                    | 01151-0935-0001  | B                              |
| Electronics Housing   | 7                    | 01151-0060-0007  |                                |
| Electronics Cover   | 1                    | 01151-1045-0001  |                                |
| Adjustment Screw, Retaining Ring,<br>and O-ring for Adjustment Screw<br>O-ring for Electronics Cover <sup>(1)</sup>                         | 2                    | 01151-0029-0001<br><br>01151-0033-0003                                   |                                |
| <b>Electronics Assembly Hardware</b><br>Standoff<br>Standoff<br>Screw<br>Screw<br>Locknut   |                      | 01151-0030-0001  |                                |

(1) Rosemount recommends one spare part for every 25 transmitters in Category A, and one spare part for every 50 transmitters in Category B.

### NOTE

The Diaphragm and Sensor Module Assembly is an oil filled system and must be serviced using the proper equipment. Contact your nearest Rosemount Service facility should it become necessary to replace or service this assembly. A complete Diaphragm and Sensor Module Assembly including the mounting flange can be ordered by specifying a complete transmitter model number from PPL 00814-0100-4526, adding "T740" to end of the model number, and deducting \$300 from the list price of the complete transmitter. (The "T740" eliminates the electronic housing and electronic circuit boards.) For example, 1151LT 4 E A0 A 12 D T740 list price 7 455 (price as of January 31, 1996) less 1 705 = 5 750 (dimensionless prices).

TABLE 5-13. (continued).

| S Output Code (Smart)<br>Part/Kit Description                              | Item No. | Part Number        |
|--|----------|--------------------|
| Smart Retrofit Kit <sup>(1)</sup>  |          | 01151-0935-0001    |
| Smart Transmitter Electronics <sup>(2)</sup>                               | 24       | 01151-0934-0204    |
| Board Spacer Kit (pkg of 12)   | 25       | 01151-0813-0001    |
| Terminal Eyelet Kit (pkg of 12)  |          | 01151-0814-0001    |
| Standoff Kit (pkg of 12)   |          | 01151-0815-0001    |
| Cover <sup>(2)</sup>   |          | 01151-1045-0001    |
| Cover O-ring (pkg of 12)   |          | 01151-0033-0003    |
| Indicating Meters<br>Part Description                                      |          | Part Number        |
| Analog Meter Kit, 4–20 mA dc, Linear Scale <sup>(3)</sup>                  |          | 01151-1046-0007    |
| Analog Meter Kit, 10–50 mA dc, Linear Scale <sup>(3)</sup>                 |          | 01151-1046-0011    |
| <b>Approved</b> Analog Meter Kit, 4–20 mA dc, Linear Scale <sup>(1)</sup>  |          | 01151-2615-0007    |
| <b>Approved</b> Analog Meter Kit, 10–50 mA dc, Linear Scale <sup>(1)</sup> |          | 01151-2615-0011    |
| LCD Meter Kit, Linear, 0–100% Flow   |          | 01151-1046-0019    |
| Analog Meter, 4–20 mA dc, Linear Scale                                     |          | 01151-0687-0004    |
| Analog Meter, 10–50 mA dc, Linear Scale                                    |          | 01151-0687-0006    |
| <b>Approved</b> Analog Meter, 4–20 mA dc, Linear Scale                     |          | 01151-2614-0004    |
| <b>Approved</b> Analog Meter, 10–50 mA dc, Linear Scale                    |          | 01151-2614-0006    |
| Special Scale for Analog Meter   |          | See note (3) below |
| LCD Meter, Linear, 0–100%  |          | 01151-1300-1000    |
| LCD Meter, Special Configuration <sup>(4)</sup>                            |          | 01151-1351-1000    |
| LCD Meter Engineering Unit Labels  |          | 01151-1351-1001    |
| Mounting Hardware and Cover Assembly Kit                                   |          | 01151-1046-0005    |
| Mounting Hardware Kit  |          | 01151-1046-0006    |
| Cover Assembly Kit   |          | 01151-1047-0001    |
| O-ring for Cover (pkg of 12)   |          | 01151-0033-0003    |

(1) Kit contains enough parts for one transmitter and includes the smart transmitter electronics, board spacers, terminal eyelets, standoffs, cover, and cover O-rings.

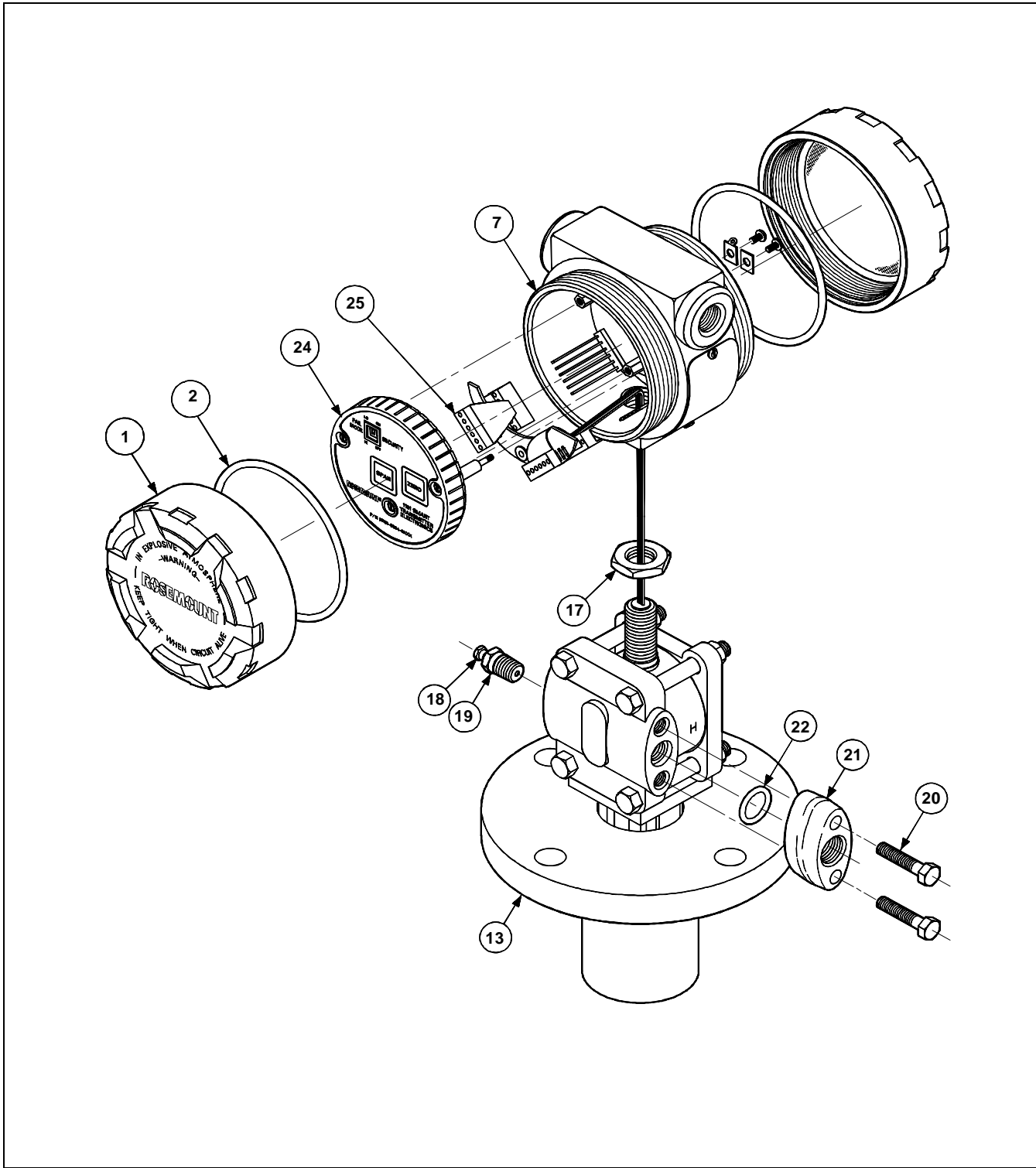
(2) Kit contains enough parts for one transmitter.

(3) Meter kit includes meter, mounting hardware, and cover assembly. For meters with special scaling, order the appropriate meter and specify the scale desired. Mounting hardware and cover assembly must be ordered separately.

(4) To order a meter with a special configuration, order the appropriate meter and indicate configuration desired.

To order a special configuration LCD meter kit, order the meter, and the mounting hardware and cover assembly kit separately.





1151-1151B08A

FIGURE 5-2. Model 1151LT Pressure Transmitter Exploded View (Analog Shown).

## SPECIFICATIONS AND REFERENCE DATA FOR OPTIONS

### LCD Meter Specifications

#### Input Signal

4–20 mA dc.

#### Meter Indication

4-digit LCD showing –999 to 9999. A 20-segment bar graph directly represents the 4–20 mA current.

#### Scaling/Calibration

4 mA Point Limits: –999 to 1000.

**Span limits:** 0200 to 9999.

The sum of the 4 mA point and span must not exceed 9999.

Adjustments are made using non-interactive zero and span buttons.

#### Hazardous Locations Certifications

Approved for use with Rosemount Models 444, 751, 1135, 1144, and 1151.

#### Overload Limitation

666 mA.

#### Temperature Limits

Storage: –40 to 85 °C (–40 to 185 °F).

Operating: –20 to 70 °C (–4 to 158 °F).

Between temperatures –40 to –20 °C (–40 to –4 °F), the loop is intact and the meter is not damaged.

#### Humidity Limitation

0 to 95% non-condensing relative humidity.

#### Update Period

750 ms.

#### Response Time

Responds to changes in input within a maximum of two update periods. If the filter is activated, then the display responds to the change within nine update periods.

#### Digital Display Resolution

0.05% of calibrated range  $\pm 1$  digit.

#### Analog Bar Graph Resolution

0.05% of calibrated range.

#### Indication Accuracy

0.25% of calibrated range  $\pm 1$  digit.

#### Stability

Over Time: 0.1% of calibrated range  $\pm 1$  digit per 6 months.

#### Temperature Effect

0.01% of calibrated range per °C on zero.

0.02% of calibrated range per °C on span over the operating temperature range.

#### Power Interrupt

All calibration constants are stored in EEPROM memory and are not affected by power loss.

**Terminal Block Specifications****Failure Mode**

LCD meter failure will not affect transmitter operation.

**Under/Over Range Indication**

Input current < 3.5 mA: Display blank.

Input current > 22.0 mA: Display flashes 112.5% of full scale value or 9999, whichever is less.

**Meter Size**

2¼-inch diameter face with ½-inch high characters.

**Hazardous Locations Certifications**

Approved for use with I5, K5, I6, C6, E6, E8, I8<sup>(1)</sup>, I1<sup>(1)</sup>, and N1 approved transmitters.

**Materials of Construction**

Noryl<sup>®</sup> plastic.

**Loop Resistance**

6 Ω

**Transient Protection Limits**

IEEE 587 Category B

6 kV Crest ( $1.2 \times 50 \mu\text{s}$ ).

3 kA Crest ( $8 \times 20 \mu\text{s}$ ).

6 kV (0.5 μs at 100 kHz).

**IEEE 472**

SWC 2.5 kV Crest, 1 MHz waveform.

**Accuracy Specification**

Same as specified electronics accuracy when transmitter is calibrated with installed retrofitable Transient Protection Terminal Block.

(1) When the transient version of the filter module is used in an intrinsically safe installation, supply transmitter from a galvanically isolated barrier.



# HART<sup>®</sup> Communicator

## INTRODUCTION

This appendix provides basic communicator information on the HART Communicator Model 275 when used with a Model 1151 Smart Pressure Transmitter.

Included in this appendix are a menu tree, a table of fast key sequences, and information on using the HART Communicator.

For more complete information on the HART Communicator, refer to the HART Communicator Product Manual 00809-0100-4275.

This brief appendix will familiarize you with the HART Communicator but is not meant to replace the HART Communicator product manual.

## SAFETY MESSAGES

### Warnings (⚠)

Procedures and instructions in this section that raise potential safety issues are indicated by a warning symbol (⚠). Refer to the following warning messages before performing an operation preceded by this symbol.

#### **WARNING**

Explosions can result in death or serious injury. Do not make connections to the serial port or NiCad recharger jack in an explosive atmosphere.

#### **WARNING**

Explosions can result in death or serious injury. Before connecting the HART Communicator in an explosive atmosphere, make sure the instruments in the loop are installed in accordance with intrinsically safe or nonincendive field wiring practices.

# Rosemount Model 1151 Smart Pressure Transmitters

FIGURE A-1. HART Communicator Menu Tree for the Model 1151.

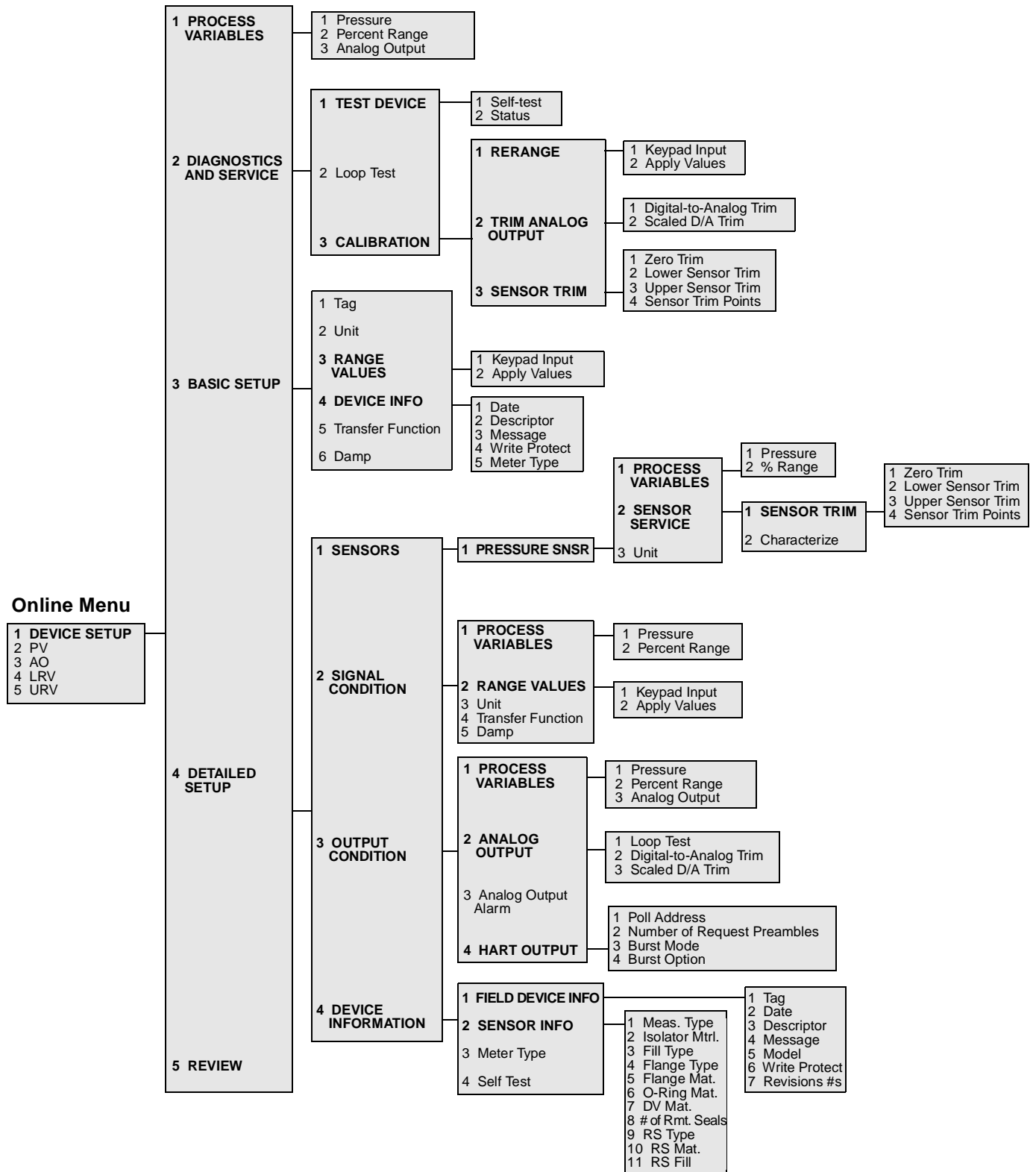


TABLE A-1. HART Fast Key Sequences for the Model 1151.

| Function                                | HART Communicator Fast Key Sequences |
|---|--------------------------------------|
| Analog Output                           | 3                                    |
| Analog Output Alarm                     | 1, 4, 3, 3                           |
| Burst Mode Control                      | 1, 4, 3, 4, 3                        |
| Burst Operation                         | 1, 4, 3, 4, 4                        |
| Calibration                             | 1, 2, 3                              |
| Characterize                            | 1, 4, 1, 1, 2, 2                     |
| Damping                                 | 1, 3, 6                              |
| Date                                    | 1, 3, 4, 1                           |
| Descriptor                              | 1, 3, 4, 2                           |
| Digital-to-Analog Trim (4–20 mA Output) | 1, 2, 3, 2, 1                        |
| Field Device Information                | 1, 4, 4, 1                           |
| Full Trim                               | 1, 2, 3, 3                           |
| Keypad Input                            | 1, 2, 3, 1, 1                        |
| Loop Test                               | 1, 2, 2                              |
| Lower Range Value                       | 4, 1                                 |
| Lower Sensor Trim                       | 1, 2, 3, 3, 2                        |
| Message                                 | 1, 3, 4, 3                           |
| Meter Type                              | 1, 3, 4, 5                           |
| Number of Requested Preambles           | 1, 4, 3, 4, 2                        |
| Percent Range                           | 1, 1, 2                              |
| Poll Address                            | 1, 4, 3, 4, 1                        |
| Pressure                                | 2                                    |
| Range Values                            | 1, 3, 3                              |
| Rerange                                 | 1, 2, 3, 1                           |
| Scaled D/A Trim (4–20 mA Output)        | 1, 2, 3, 2, 2                        |
| Self-Test (Transmitter)                 | 1, 2, 1, 1                           |
| Sensor Information                      | 1, 4, 4, 2                           |
| Sensor Trim Points                      | 1, 2, 3, 3, 4                        |
| Status                                  | 1, 2, 1, 2                           |
| Tag                                     | 1, 3, 1                              |
| Transfer Function (Setting Output Type) | 1, 3, 5                              |
| Transmitter Security (Write Protect)    | 1, 3, 4, 4                           |
| Trim Analog Output                      | 1, 2, 3, 2                           |
| Units (Process Variable)                | 1, 3, 2                              |
| Upper Range Value                       | 5, 2                                 |
| Upper Sensor Trim                       | 1, 2, 3, 3, 3                        |
| Zero Trim                               | 1, 2, 3, 3, 1                        |

## CONNECTIONS AND HARDWARE


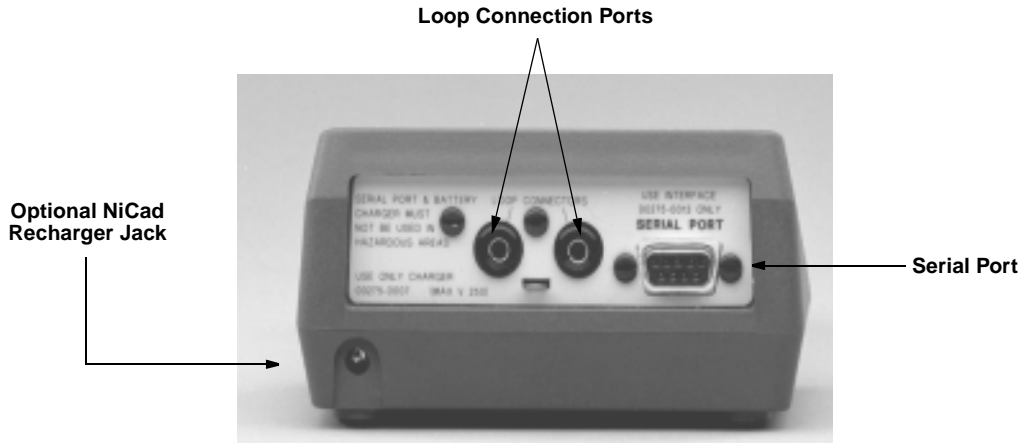
 The HART Communicator Model 275 can interface with a transmitter from the control room, the instrument site, or any wiring termination point in the loop through the rear connection panel as shown in Figure A-2. To communicate, connect the HART Communicator in parallel with the instrument or load resistor. The connections are non-polarized.

FIGURE A-2. Rear Connection Panel with Optional NiCad Recharger Pack.



275-008AB

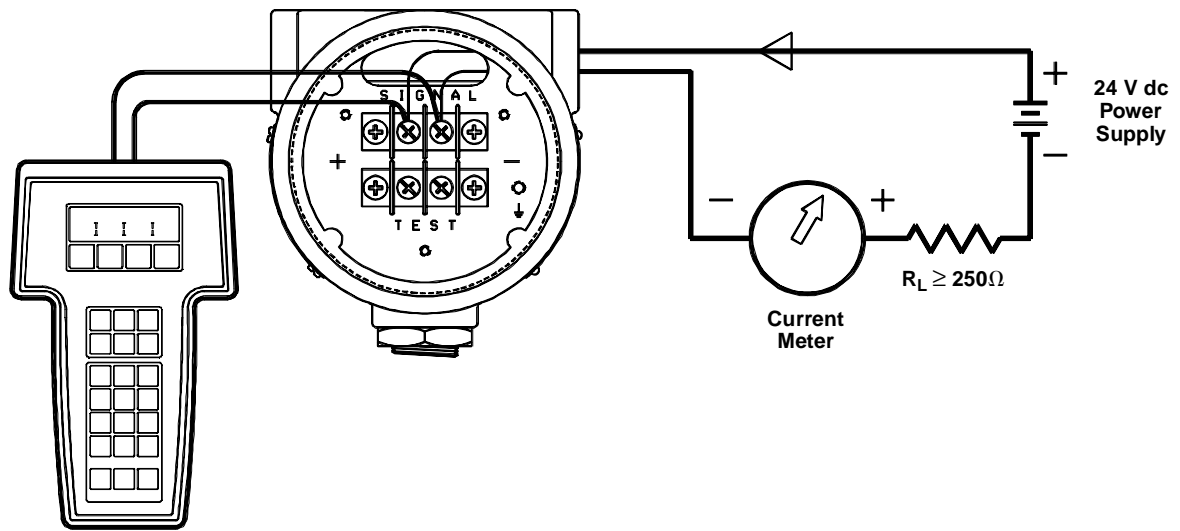
### NOTE

The HART Communicator needs a minimum of 250 ohms resistance in the loop to function properly. The HART Communicator does not measure loop current directly.



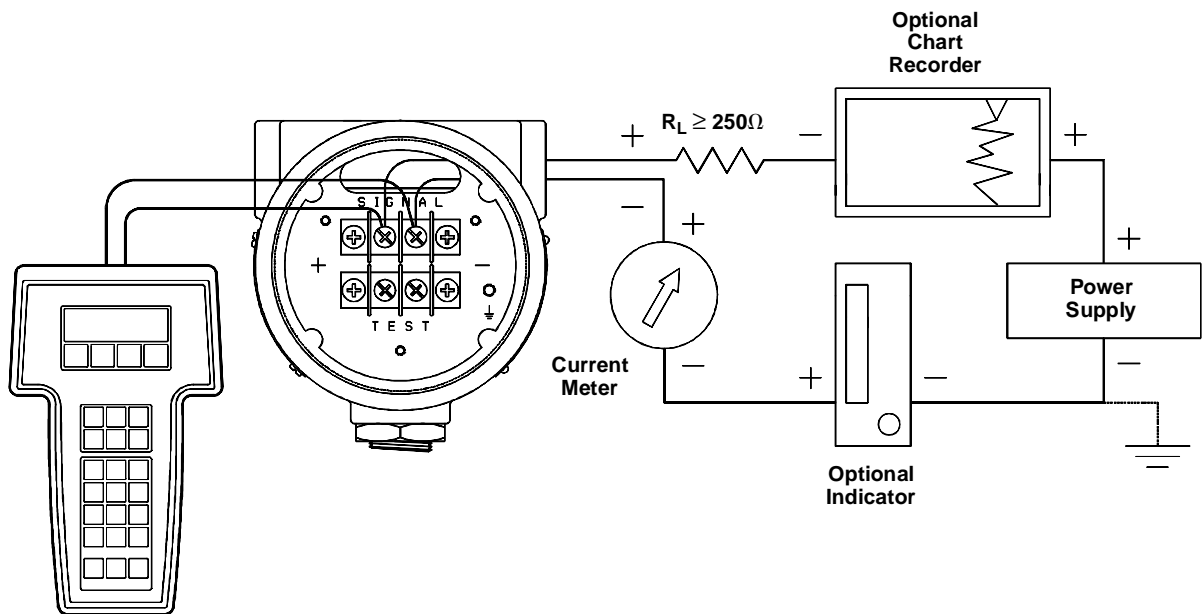


FIGURE A-3. Bench Hook-up  
(Smart Transmitters).



1151-1151G05B

FIGURE A-4. Field Hook-up  
(Smart Transmitters).

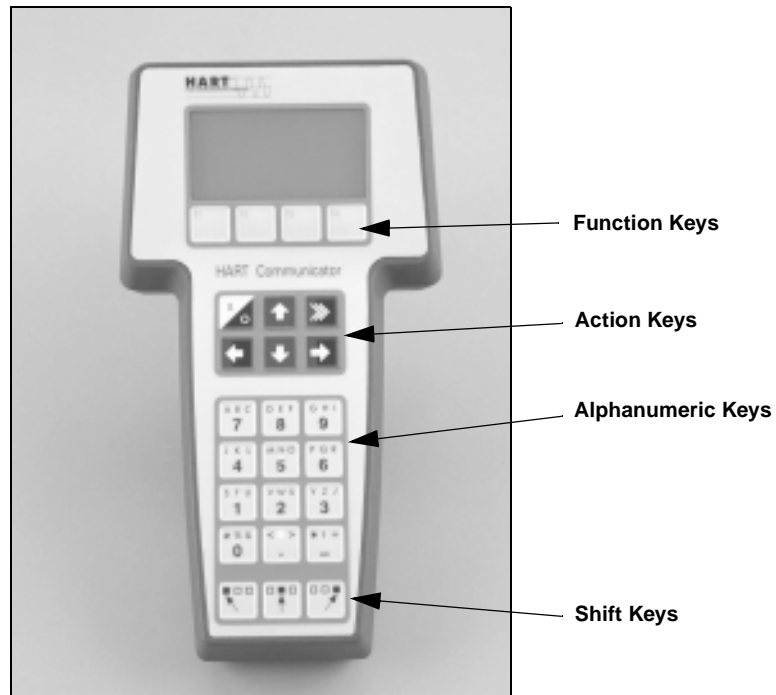


1151-1151F05E

## COMMUNICATOR KEYS

The keys of the HART Communicator include action, function, and alphanumeric and shift keys.

FIGURE A-5. The HART Communicator.



### Action Keys

As shown in Figure A-5, the action keys are the six blue, white, and black keys located above the alphanumeric keys. The function of each key is described as follows:

#### ON/OFF Key

Use this key to power the HART Communicator. When the communicator is turned on, it searches for a transmitter on the 4–20 mA loop. If a device is not found, the communicator displays the message, “No Device Found. Press OK.”

If a HART-compatible device is found, the communicator displays the Online Menu with device ID and tag.

#### Directional Keys

Use these keys to move the cursor up, down, left, or right. The right arrow key also selects menu options, and the left arrow key returns to the previous menu.

#### HOT Key

Use this key to quickly access important, user-selectable options when connected to a HART-compatible device. Pressing the Hot Key turns the HART Communicator on and displays the Hot Key Menu. See Customizing the Hot Key Menu in the HART Communicator manual for more information.

## Function Keys

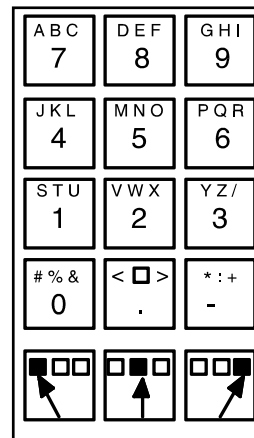


Use the four software-defined function keys, located below the LCD, to perform software functions. On any given menu, the label appearing above a function key indicates the function of that key for the current menu. As you move among menus, different function key labels appear over the four keys. For example, in menus providing access to on-line help, the **HELP** label may appear above the F1 key. In menus providing access to the Online Menu, the **HOME** label may appear above the F3 key. Simply press the key to activate the function. See your HART Communicator manual for details on specific function key definitions.

## Alphanumeric and Shift Keys

The alphanumeric keys (Figure A-6) perform two functions: the fast selection of menu options and data entry.

FIGURE A-6. HART Communicator Alphanumeric and Shift Keys.

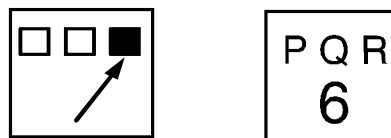


### Data Entry

Some menus require data entry. Use the alphanumeric and shift keys to enter all alphanumeric information into the HART Communicator. If you press an alphanumeric key alone from within an edit menu, the bold character in the center of the key appears. These large characters include the numbers 0 through 9, the decimal point (.), and the dash symbol (—).

To enter an alphabetic character, first press the shift key that corresponds to the position of the letter you want on the alphanumeric key. Then press the alphanumeric key. For example, to enter the letter R, first press the right shift key, then the “6” key (see Figure A-7). Do not press these keys simultaneously, but one after the other.

FIGURE A-7. Data Entry Key Sequence.



## HART FAST KEY SEQUENCES

HART fast key sequences provide quick on-line access to transmitter variables and functions. Instead of stepping your way through the menu structure using the action keys, you can press a HART fast key sequence to move from the Online Menu to the desired variable or function. On-screen instructions guide you through the rest of the screens.

### HART Fast Key Example

HART fast key sequences are made up of the series of numbers corresponding to the individual options in each step of the menu structure. For example, from the Online Menu you can change the **Date**. Following the menu structure, press 1 to reach **Device Setup**, press 3 for **Basic Setup**, press 4 for **Device Info**, press 5 for **Date**. The corresponding HART fast key sequence is 1,3,4,5.

HART fast keys are operational only from the Online Menu. If you use them consistently, you will need to return to the Online Menu by pressing **HOME** (F3) when it is available. If you do not start at the Online Menu, the HART fast key sequences will not function properly.

Use Table A-1, an alphabetical listing of every on-line function, to find the corresponding HART fast key sequences. These codes are applicable only to Model 1151 transmitters and the HART Communicator.

## MENUS AND FUNCTIONS

The HART Communicator is a menu driven system. Each screen provides a menu of options that can be selected as outlined above, or provides direction for input of data, warnings, messages, or other instructions.

### Main Menu

When the HART Communicator is turned on, one of two menus will appear. If the HART Communicator is connected to an operating loop, the communicator will find the device and display the Online Menu (see below). If it is not connected to a loop, the communicator will indicate that no device was found. When you press OK (F4), it will display the Main menu.

The Main menu provides the following options:

- *Offline*—The Offline option provides access to offline configuration data and simulation functions.
- *Online*—The Online option checks for a device and if it finds one, brings up the Online Menu.
- *Transfer*—The Transfer option provides access to options for transferring data either from the HART Communicator (memory) to the transmitter (device) or vice versa. Transfer is used to move off-line data from the HART Communicator to the transmitter, or to retrieve data from a transmitter for off-line revision.

---

### NOTE

Online communication with the transmitter automatically loads the current transmitter data to the HART Communicator. Changes in on-line data are made active by pressing SEND (F2). The transfer function is used only for off-line data retrieval and sending.

---

- *Frequency Device*—The Frequency Device option displays the frequency output and corresponding pressure output of current-to-pressure transmitters.
- *Utility*—The Utility option provides access to the contrast control for the HART Communicator LCD screen and to the autopoll setting used in multidrop applications.

Once selecting a Main menu option, the HART Communicator provides the information you need to complete the operation. If further details are required, consult the HART Communicator manual.

## Online Menu

The Online Menu can be selected from the Main menu as outlined above, or it may appear automatically if the HART Communicator is connected to an active loop and can detect an operating transmitter.

---

### NOTE

The Main menu can be accessed from the Online Menu. Press the left arrow action key to deactivate the on-line communication with the transmitter and to activate the Main menu options.

---

When configuration variables are reset in the on-line mode, the new settings are not activated until the data are sent to the transmitter. Press SEND (F2) when it is activated to update the process variables of the transmitter.

On-line mode is used for direct evaluation of a particular meter, re-configuration, changing parameters, maintenance, and other functions.

## DIAGNOSTIC MESSAGES

The following pages contain a list of messages used by the HART Communicator (HC) and their corresponding descriptions.

Variable parameters within the text of a message are indicated with *<variable parameter>*.

Reference to the name of another message is identified by *[another message]*.

| Message  | Description   |
|--|---|
| <b>Add item for ALL device types or only for this ONE device type.</b> | Asks the user whether the hot key item being added should be added for all device types or only for the type of device that is connected.                       |
| <b>Command not implemented</b>   | The connected device does not support this function.  |
| <b>Communication error</b>   | Either a device sends back a response indicating that the message it received was unintelligible, or the HC cannot understand the response from the device.     |
| <b>Configuration memory not compatible with connected device</b>       | The configuration stored in memory is incompatible with the device to which a transfer has been requested.  |
| <b>Device busy</b>   | The connected device is busy performing another task.   |
| <b>Device disconnected</b>   | Device fails to respond to a command.   |
| <b>Device write protected</b>  | Device is in write-protect mode. Data cannot be written.  |
| <b>Device write protected. Do you still want to shut off?</b>          | Device is in write-protect mode. Press YES to turn the HC off and lose the unsent data.   |
| <b>Display value of variable on hot key menu?</b>                      | Asks whether the value of the variable should be displayed adjacent to its label on the hot key menu if the item being added to the hot key menu is a variable. |
| <b>Download data from configuration memory to device</b>               | Prompts user to press SEND softkey to initiate a memory to device transfer.   |
| <b>Exceed field width</b>  | Indicates that the field width for the current arithmetic variable exceeds the device-specified description edit format.  |
| <b>Exceed precision</b>  | Indicates that the precision for the current arithmetic variable exceeds the device-specified description edit format.  |
| <b>Ignore next 50 occurrences of status?</b>                           | Asked after displaying device status. Softkey answer determines whether next 50 occurrences of device status will be ignored or displayed.                      |
| <b>Illegal character</b>   | An invalid character for the variable type was entered.   |
| <b>Illegal date</b>  | The day portion of the date is invalid.   |
| <b>Illegal month</b>   | The month portion of the date is invalid.   |
| <b>Illegal year</b>  | The year portion of the date is invalid.  |
| <b>Incomplete exponent</b>   | The exponent of a scientific notation floating point variable is incomplete.  |
| <b>Incomplete field</b>  | The value entered is not complete for the variable type.  |
| <b>Looking for a device</b>  | Polling for multidropped devices at addresses 1–15.   |

| Message   | Description  |
|---|--|
| <b>Mark as read only variable on hot key menu?</b>                                  | Asks whether the user should be allowed to edit the variable from the hot key menu if the item being added to the hot key menu is a variable.                  |
| <b>No device configuration in configuration memory</b>                              | There is no configuration saved in memory available to re-configure off-line or transfer to a device.  |
| <b>No device found</b>  | Poll of address zero fails to find a device, or poll of all addresses fails to find a device if auto-poll is enabled.  |
| <b>No hot key menu available for this device.</b>                                   | There is no menu named "hot key" defined in the device description for this device.  |
| <b>No offline devices available.</b>  | There are no device descriptions available to be used to configure a device offline.   |
| <b>No simulation devices available.</b>   | There are no device descriptions available to simulate a device.   |
| <b>No UPLOAD_VARIABLES in ddl for this device</b>                                   | There is no menu named "upload_variables" defined in the device description for this device. This menu is required for offline configuration.                  |
| <b>No valid items</b>   | The selected menu or edit display contains no valid items.   |
| <b>OFF KEY DISABLED</b>   | Appears when the user attempts to turn the HC off before sending modified data or before completing a method.  |
| <b>Online device disconnected with unsent data. RETRY or OK to lose data.</b>       | There is unsent data for a previously connected device. Press RETRY to send data, or press OK to disconnect and lose unsent data.                              |
| <b>Out of memory for hot key configuration. Delete unnecessary items.</b>           | There is no more memory available to store additional hot key items. Unnecessary items should be deleted to make space available.                              |
| <b>Overwrite existing configuration memory</b>                                      | Requests permission to overwrite existing configuration either by a device-to-memory transfer or by an offline configuration. User answers using the softkeys. |
| <b>Press OK...</b>  | Press the OK softkey. This message usually appears after an error message from the application or as a result of HART communications.                          |
| <b>Restore device value?</b>  | The edited value that was sent to a device was not properly implemented. Restoring the device value returns the variable to its original value.                |
| <b>Save data from device to configuration memory</b>                                | Prompts user to press SAVE softkey to initiate a device-to-memory transfer.  |
| <b>Saving data to configuration memory.</b>   | Data is being transferred from a device to configuration memory.   |
| <b>Sending data to device.</b>  | Data is being transferred from configuration memory to a device.   |
| <b>There are write only variables which have not been edited. Please edit them.</b> | There are write-only variables which have not been set by the user. These variables should be set or invalid values may be sent to the device.                 |

| Message  | Description  |
|--|--|
| <b>There is unspent data. Send it before shutting off?</b>   | Press YES to send unspent data and turn the HC off. Press NO to turn the HC off and lose the unspent data.   |
| <b>Too few data bytes received</b>   | Command returns fewer data bytes than expected as determined by the device description.  |
| <b>Transmitter fault</b>   | Device returns a command response indicating a fault with the connected device.  |
| <b>Units for &lt;variable label&gt; has changed. Unit must be sent before editing, or invalid data will be sent.</b> | The engineering units for this variable have been edited. Send engineering units to the device before editing this variable.   |
| <b>Unspent data to online device. SEND or LOSE data</b>  | There is unspent data for a previously connected device which must be sent or thrown away before connecting to another device.   |
| <b>Use up/down arrows to change contrast. Press DONE when done.</b>  | Gives direction to change the contrast of the HC display.  |
| <b>Value out of range</b>  | The user-entered value is either not within the range for the given type and size of variable or not within the min/max specified by the device.   |
| <b>&lt;message&gt; occurred reading/writing &lt;variable label&gt;</b>   | Either a read/write command indicates too few data bytes received, transmitter fault, invalid response code, invalid response command, invalid reply data field, or failed pre- or post-read method; or a response code of any class other than SUCCESS is returned reading a particular variable. |
| <b>&lt;variable label&gt; has an unknown value. Unit must be sent before editing, or invalid data will be sent.</b>  | A variable related to this variable has been edited. Send related variable to the device before editing this variable.   |



---

## **Model 268 Communicator**

### **INTRODUCTION**

This appendix provides basic communicator information on the Rosemount Model 268 SMART FAMILY Interface when used with a Model 1151 Smart Pressure Transmitter.

Included in this appendix are a menu tree, a table of fast key sequences, and information on using the Rosemount Model 268 SMART FAMILY Interface.

FIGURE B-1. 268 Menu Tree.

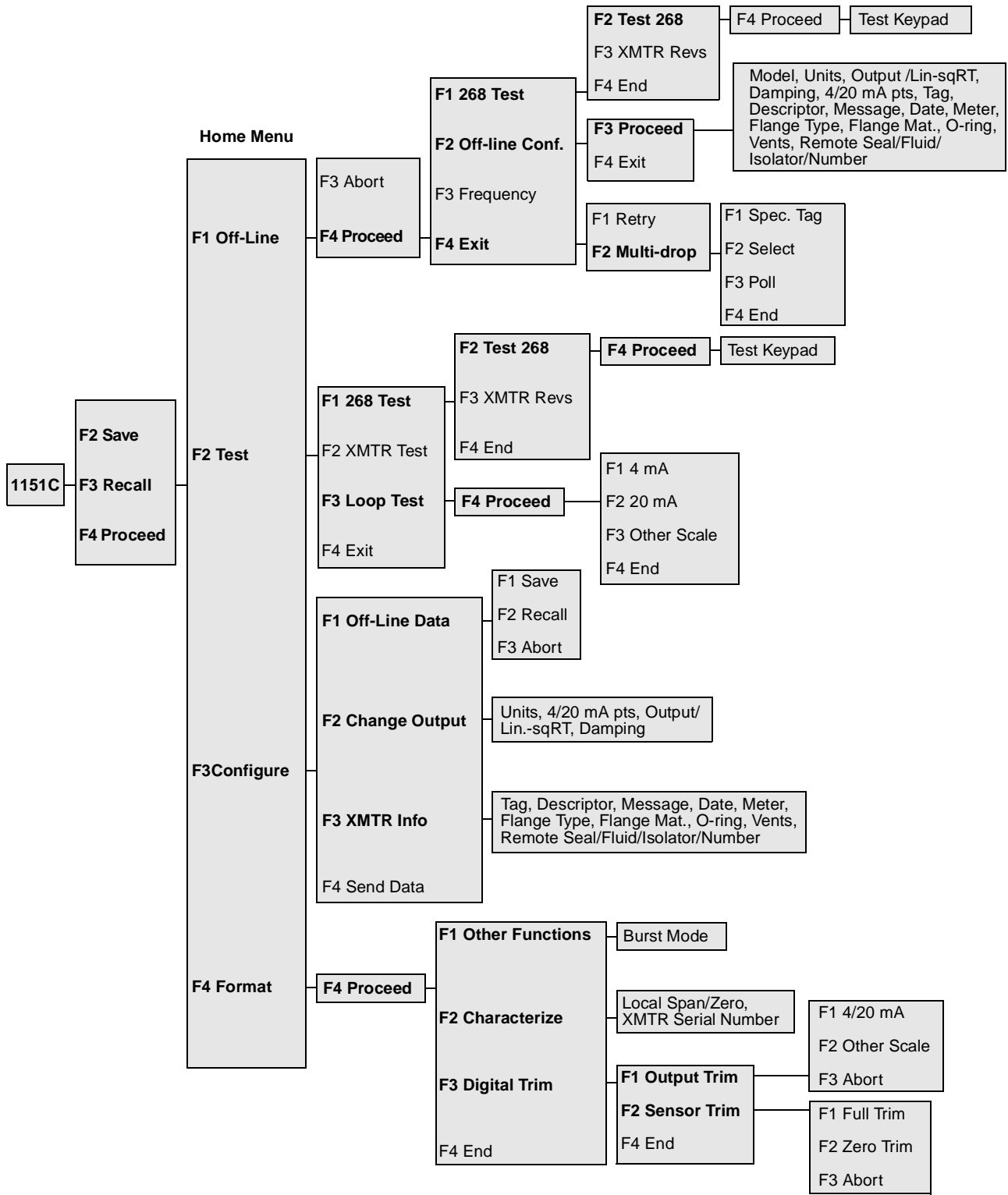


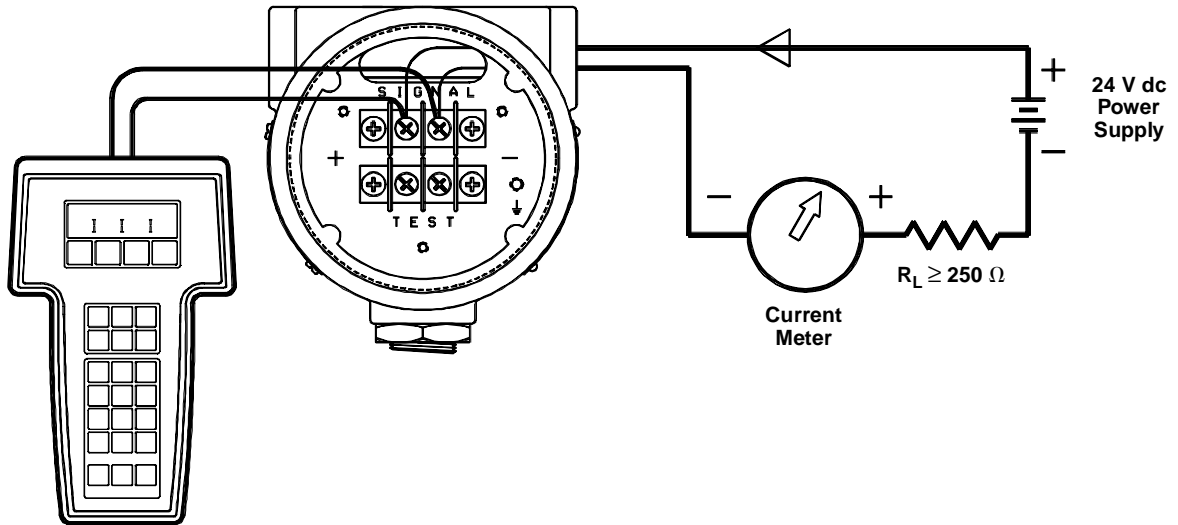
TABLE B-2. Model 268 Fast Key Equivalents.

| Function                                | Model 268 Fast Key Sequences |
|---|------------------------------|
| Analog Output                           | F3, F2                       |
| Analog Output Alarm                     | Not Applicable               |
| Burst Mode Control                      | F4, F4, F1                   |
| Burst Operation                         | Not Applicable               |
| Calibration                             | Not Applicable               |
| Characterization                        | F4, F4, F2                   |
| Damping                                 | F3, F2, F2                   |
| Date                                    | F3, F3, (F1 x 3)             |
| Descriptor                              | F3, F3, F1                   |
| Digital To Analog Trim (4–20 mA Output) | F4, F4, F3                   |
| Disable Local Span/Zero Adjustment      | F4, F4, F1                   |
| Field Device Information                | F3, F3                       |
| Full Trim                               | F4, F4, F3, F2, F1           |
| Keypad Input (Trim Points)              | F3, F2, F1                   |
| Loop Test                               | F2, F3                       |
| Lower Range Value                       | Process Variable Key, F2     |
| Lower Sensor Trim                       | F4, F4, F3, F2, F1, F2       |
| Message                                 | F3, F3, F1, F1               |
| Meter Type                              | F3, F3, (F1 x 4)             |
| Number Of Requested Preambles           | Not Applicable               |
| Percent Range                           | Not Applicable               |
| Poll Address                            | F1, F4, F4, F2, F3           |
| Pressure                                | Process Variable Key         |
| Range Values                            | F3, F2, F1                   |
| Rerange                                 | F4, F4, F3, F1, F1           |
| Scaled D/A Trim (4–20 mA Output)        | F4, F4, F3, F1, F2           |
| Self Test (Transmitter)                 | F2, F2                       |
| Sensor Information                      | F3, F3                       |
| Sensor Temperature                      | Process Variable Key, F3     |
| Sensor Trim Points                      | F3, F2, F1                   |
| Status                                  | Not Applicable               |
| Tag                                     | F3, F3                       |
| Transfer Function (Setting Output Type) | F3, F2, F1, F1               |
| Transmitter Security (Write Protect)    | Not Applicable               |
| Trim Analog Output                      | F4, F4, F3, F1               |
| Units (Process Variable)                | F3, F2                       |
| Upper Range Value                       | Process Variable Key, F2     |
| Upper Sensor Trim                       | F4, F4, F3, F2, F1, F3       |
| Zero Trim                               | F4, F4, F3, F2, F2           |

**CONNECTIONS AND  
HARDWARE**

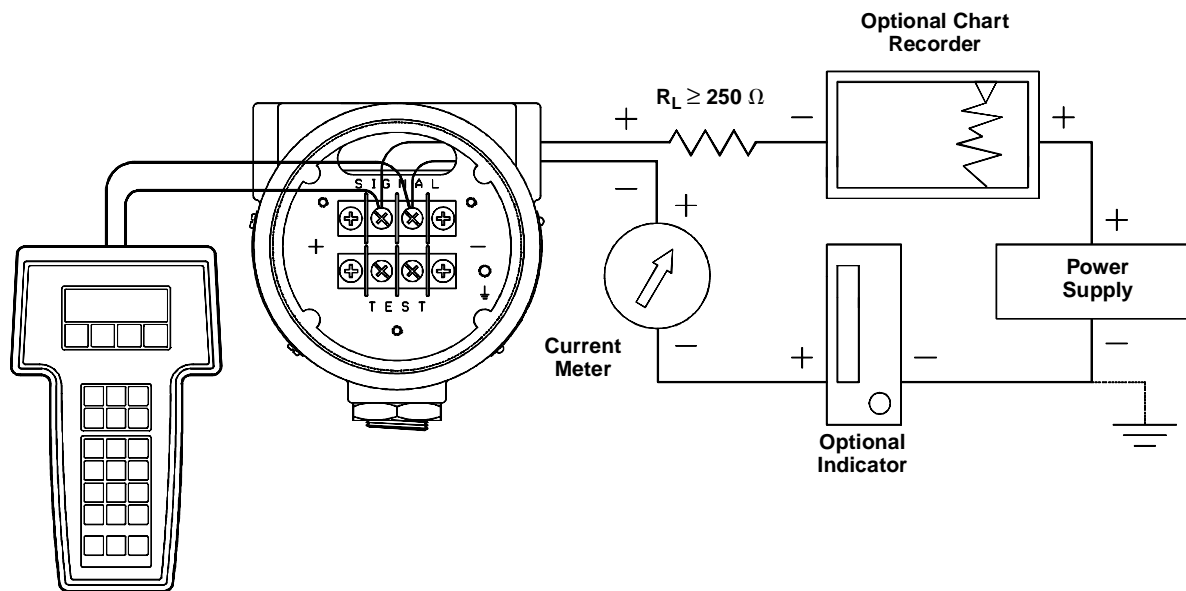
The Model 268 can communicate with a transmitter from the control room, the transmitter site, or any other wiring termination point in the loop. To communicate, it must be connected in parallel with the transmitter; the connections are non-polarized.

FIGURE B-3. Bench Hook-up  
(Smart Transmitters).



1151-1151G05B

FIGURE B-4. Field Hook-up  
(Smart Transmitters).



1151-1151G05E

## COMMUNICATOR KEYS

The keys of the Model 268 include the dedicated, alphanumeric and shift, and function keys that vary depending on the task being performed. The dedicated key functions are always the same.

### Dedicated Keys

#### On/Off

Use this key to turn the unit on and off. When the Model 268 is turned ON, it searches for a transmitter in the 4–20 mA loop. If no transmitter is found, the Model 268 offers the opportunity to try again, select “MULT DROP” or “OFF-LINE”.

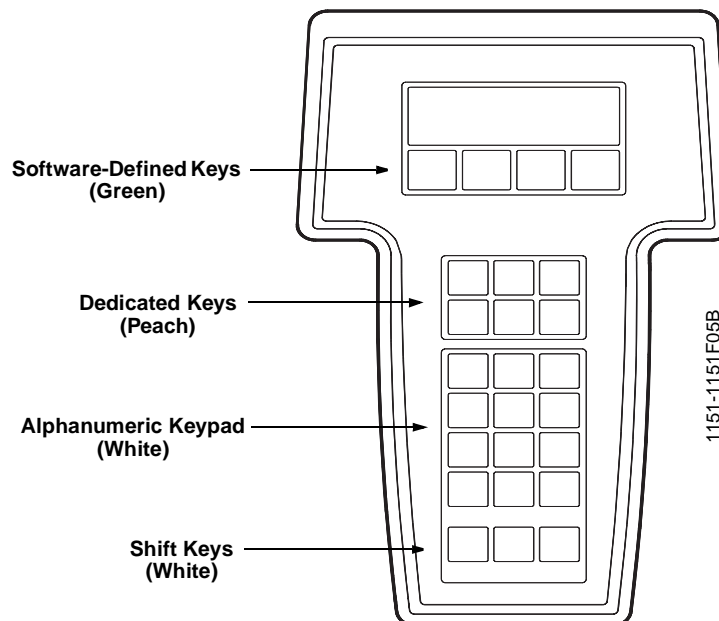
#### Process Variable

Use the Process Variable key to display up-to-date process variable readings from the transmitter in engineering units, milliamps, pulse rate, and shedding rate. It also displays totalized flow.

#### Review

The Review key allows you to step through all the information currently held in the four memory locations of the transmitter and Model 268 — SAFE MEM, OFLN MEM, WORK REG, and XMTR MEM.

FIGURE B-5. Model 268 Communicator.



#### Help

Use the Help key to explain the software-defined key functions (F1-F4) in detail.

#### Restart

Use the Restart key to initiate communication with a transmitter while the Model 268 is still turned on. Upon connection to a new transmitter, pressing this key loads information from the new transmitter into the Model 268 working register.

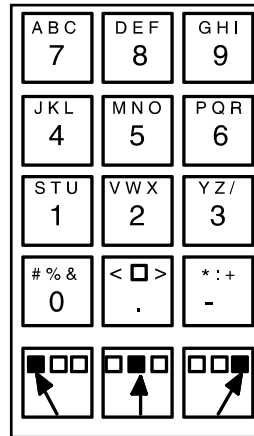
#### Previous Function

The Previous Function key returns you to the previous decision level and allows you to select a different software-defined key function.

## Alphanumeric and Shift Keys

Some menus require data entry. Use the alphanumeric and shift keys to enter all alphanumeric information into the Model 268.

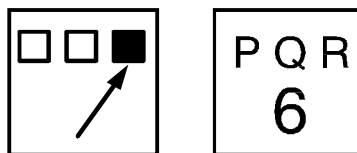
FIGURE B-6. Model 268 Communicator Alphanumeric and Shift Keys.



If you press an alphanumeric key alone from within an edit menu, the bold character in the center of the key appears. These characters include the numbers 0 through 9, the decimal point (.), and the dash symbol (-).

To enter an alphabetic character, first press the shift key that corresponds to the position of the letter you want on the alphanumeric key. Then press the alphanumeric key. For example, to enter the letter R, first press the right shift key, then the “6” key (see Figure B-7). Do not press these keys simultaneously, but one after the other.

FIGURE B-7. Data Entry Key Sequence.



## Function Keys

Use the four software-defined function keys, located below the LCD, to perform software functions. On any given menu, the label appearing above a function key indicates the function of that key for the current menu. As you move among menus, different function key labels appear over the four keys.

## FAST KEY SEQUENCES

The Model 268 fast key sequences provide quick on-line access to transmitter variables and functions. Instead of stepping your way through the menu structure, you can press a fast key sequence to move from the Home Menu to the desired variable or function. On-screen instructions guide you through the rest of the screens.

### Fast Key Sequence Conventions

The fast key sequences for the Model 268 use the following conventions for their identification:

**F1, F2, F3, F4**—Refer to each function key located directly below the LCD on the Model 268.

**(F2 x 7)**—Means to push the F2 key seven consecutive times.

**Process Variable**—Refers to the dedicated key located below the function keys on the Model 268.

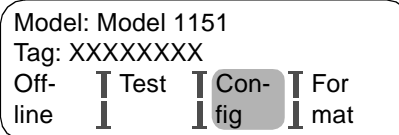
To return to the Home Menu, use the function keys to exit the current task and press the PREVIOUS FUNCTION (dedicated key) as many times as necessary.

The fast key sequences are applicable only from the Home Menu. The Home Menu lists the model and tag, and labels the four function keys Offline, Test, Configure and Format (see Figure B-8). After completing a task, return to the Home Menu if you intend to use the fast key sequences. Fast key sequences will not work from any other Model 268 screen.

#### NOTE

Certain tasks require that you set the control loop to manual control before completing them. Fast key sequences often include a warning to return the loop to manual.

FIGURE B-8. Model 268 Home Screen.



To return to the Home Menu, use the function keys to exit the current task and press PREVIOUS FUNCTION as many times as necessary. When the Home Menu appears, you can use another fast key sequence to reach a desired task.

#### NOTE

Certain tasks require that you set the control loop to manual control before completing them. Fast key sequence steps often include the warning to return the loop to manual. If the loop is not in manual control, be sure to watch for this screen. If it comes up during the fast key sequence, set the loop to manual before continuing with the task.

### Fast Key Sequence Examples

#### Date

To change the date following the menu structure, you would start at the Home Menu and press F3 for **Configure**, F3 for **XMTR Info**, and F1 three times in a row to reach the Date function. The fast key sequence is F3, F3, [F1 x 3].

#### Loop Test

To perform the Loop Test, start at the Home Menu and press F2 for Test, F3 for Loop Test, and F4 for Proceed (after the loop is set to manual). The Function Key Sequence is F2, F3, F4.

**DIAGNOSTICS MESSAGES**

The following table provides a guide to diagnostic messages of the Model 268.

| Message   | Description  |
|---|--|
| <b>CAUTION–<br/>Progressing will clear<br/>OfIn Mem</b>           | Off-line Memory is cleared for new information.  |
| <b>Data saved in OFLN<br/>Mem for downloading</b>                 | Off-line configuration data are saved in the Off-line Memory and can be downloaded or sent to the flowmeter at an appropriate time.  |
| <b>Different XMTR type<br/>connected–XMTR<br/>Mem not changed</b> | The flowmeter did not accept data sent because the data is meant for a different type of transmitter.  |
| <b>End of list</b>  |  |
| <b>ERR–filter auto adjust</b>                                     | The low pass filter auto-adjust sequence error occurs under the following conditions: <ul style="list-style-type: none"> <li>• no flow in pipe</li> <li>• erratic flowrate</li> <li>• filter tracking disabled</li> </ul> Remedy conditions and repeat function. |
| <b>ERR–Hard/software is<br/>not compatible</b>                    |  |
| <b>ERR–Not in output<br/>mode</b>                                 |  |
| <b>ERR–Not XMTR<br/>command</b>                                   | The flowmeter does not understand the command sent by the Model 268. Press F4, RESTART to restart the flowmeter, or press F3 to suppress the error message and REVIEW the software revision level. You may need to contact the Rosemount Service Center.         |
| <b>ERR–Out of range</b>   |  |
| <b>ERR–PV out of limits</b>                                       |  |
| <b>ERR–Update failure</b>   |  |
| <b>ERR–Value was too hi</b>                                       |  |
| <b>ERR–Value was too lo</b>                                       |  |
| <b>ERR–XMTR fault</b>   |  |
| <b>ERR–XMTR will not<br/>support command</b>                      | The flowmeter does not understand the Model 268 command. Press F4, RESTART or press F3, REVIEW to review the software revision level of the flowmeter. Check compatibility.  |
| <b>ERR–268 Data err</b>   |  |
| <b>Errors Detected–XMTR<br/>Mem not changed</b>                   | The flowmeter did not accept data because it contained nonpermissible values. Data errors must be corrected and the data sent again.   |
| <b>FAILURE–Electronics</b>  |  |
| <b>Gen failure–No. 1</b>  |  |
| <b>Making changes<br/>permanent–PLEASE<br/>WAIT</b>               | Data is being sent to the flowmeter and the flowmeter is accepting the data.   |
| <b>No data modified to<br/>send</b>                               | Data with no changes is being sent. Press F4 to continue.  |
| <b>No data saved in OFLN<br/>Mem</b>                              | There are no data in the Off-line Memory to review.  |



| Message  | Description  |
|--|--|
| <b>No data saved in SAFE Mem</b>                                   | There are no data in the Safe Memory to review.  |
| <b>OfIn Mem not compatible with WORK REGS—Data not transferred</b> | The data stored in Off-line Memory and Working Register are from different kinds of transmitters, or the Off-line Memory is empty. Press F4, REVIEW, F2 to see the data in Off-line Memory and connect the Model 268 to similar transmitter. |
| <b>SAFE Mem from diff XMTR than WORK REGS—Data not transferred</b> | Data in the Safe Memory and Working Register are from different transmitters. Press F4, REVIEW, F1 and find the flowmeter serial number. Connect the Model 268 to the flowmeter with that serial number and press RESTART.                   |
| <b>SAFE Mem not compatible with WORK REGS—Data not transferred</b> | The unique identifier in the Safe Memory and the transmitter are different. Press F4, REVIEW, F1 to see the data in the Safe Memory. Connect the Model 268 to the matching transmitter and press RESTART.                                    |
| <b>The XMTR has returned an error</b>                              |  |
| <b>WARN—Used nearest legal table value</b>                         | The value entered has too many decimal places. The Model 8800 defaults to the closest value available.   |
| <b>WARN—Value at limit reverse direction</b>                       | The entered value is beyond the upper or lower limit. Adjust to a value within the limits.   |
| <b>WARN—Value entered is illegal, re-enter</b>                     | The Model 268 will not accept the entered value. Enter an acceptable value (see relevant section in manual).   |
| <b>WARN—Value out of limits, altered by 268, re-check data</b>     | The Model 268 could not store the entered value so it changed to the maximum allowable value. Check the new value.   |
| <b>WARNING—Analog output outside range points</b>                  |  |
| <b>WARNING—Control loop should be in manual</b>                    | Before sending the data that could affect the 4–20 mA output signal, set the loop to manual control. After it is set, press F4.  |
| <b>WARNING—Data transmission error</b>                             | Previous communication between Model 268 and the flowmeter was not successful. If this message appears repeatedly, check the loop for a source of noise that could corrupt the signal.   |
| <b>WARNING—Loop may be returned to auto</b>                        | After completing a communication that required the loop to be set in manual, you may return the loop to automatic control.   |
| <b>WARNING—Match xmtr S/N to nameplate S/N</b>                     | Check to be sure that the entered flowmeter serial number is the same as that on the flowmeter nameplate.  |
| <b>WARNING—Not on line</b>   | The key you have pressed is not applicable for off-line configuration tasks.   |
| <b>WARNING—Process has been aborted</b>                            | Indicates that the self-test has been aborted by pressing any key.   |
| <b>WARNING—PV out of range</b>                                     |  |
| <b>WARNING—Some of the changes were not saved in the xmtr mem</b>  | Flowmeter did not receive all configuration changes. Note differences in configuration data and reconfigure the flowmeter accordingly.   |
| <b>WARNING—This address already being used</b>                     | Another transmitter is already using the entered multi-drop address. Enter a new address.  |

| Message   | Description  |
|---|--|
| <b>WARNING—This will erase work reg</b>                         | Data in the Working Register will be replaced with data from a another location.   |
| <b>WARNING—XMTR/268 not in communication</b>                    | Model 268 did not get answer from flowmeter: <ul style="list-style-type: none"> <li>• Check connections</li> <li>• Check that power is reaching flowmeter</li> <li>• Check for minimum 250 ohms resistance in loop</li> </ul>  |
| <b>WARNING—XMTR in output mode</b>                              | During start-up and restart, the transmitter milliamp output does not reflect the process variable. Press F4.  |
| <b>WARNING—XMTR is not communicating</b>                        | Model 268 did not get answer from flowmeter: <ul style="list-style-type: none"> <li>• Check connections</li> <li>• Check that power is reaching flowmeter</li> <li>• Check for minimum 250 ohms resistance in loop</li> </ul>  |
| <b>WARNING—268 does not know this XMTR</b>                      | Model 268 recognizes a Rosemount transmitter in the loop but cannot communicate with it. The message usually indicates a software revision level incompatibility between the Model 268 and the transmitter.  |
| <b>XMTR Mem diff than WORK Regs—XMTR not changed</b>            | Data in the Working Register and in the flowmeter have different unique identifiers. The Model 268 was probably connected to different flowmeter without RESTART or power-off/power-on sequence. Press RESTART to erase the Working Register or save the Working Register to the Off-line Memory and download to the proper flowmeter at a later time. |
| <b>XMTR Security: On—XMTR will not accept changes to Memory</b> |  |
| <b>XMTR still busy</b>  | Flowmeter is running a computational or diagnostic routine and cannot respond to the Model 268 instructions. Press the PREVIOUS FUNCTION key to cancel.  |
| <b>XXXX=YYYY ERR—Illegal value</b>                              |  |
| <b>XXXX=YYYY ERR—Out of range</b>                               |  |
| <b>XXXX=YYYY ERR—Span too small</b>                             |  |
| <b>XXXX=YYYYERR—Valu was too hi</b>                             |  |
| <b>XXXX=YYYYERR—Valu was too lo</b>                             |  |
| <b>XXXX=YYYY ERR—LRV too hi</b>                                 |  |
| <b>XXXX=YYYY ERR—LRV too lo</b>                                 |  |
| <b>XXXX=YYYY ERR—LRV &amp; URV out limits</b>                   |  |
| <b>XXXX=YYYYERR—URV too hi</b>                                  |  |
| <b>XXXX=YYYYERR—URV too lo</b>                                  |  |
| <b>XXXX=YYYY ERR—268 data err</b>                               |  |
| <b>268 Failure—No. 1</b>  |  |
| <b>268 Failure—No. 2</b>  |  |
| <b>268 Test: FAIL</b>   |  |

# Retrofitting the Model 1151 Transmitter

## INTRODUCTION

This section describes how the Rosemount Smart Retrofit Kit can be used to retrofit a Model 1151AP, DP, GP, HP, or LT transmitter with 4-20 mA dc linear or square root output.

### NOTE

The Model 1151DR (Draft Range) Transmitter cannot be retrofitted with the 1151-0935-0001 Retrofit Kit. In addition, Model 1151 transmitters with serial numbers below 10,000 and approximately 2,000 Model 1151 AP Range Code 4 Transmitters with serial numbers between 1,318,500 and 1,690,000 may experience some degradation in performance from temperature effect if retrofitted. Therefore, retrofitting of these transmitters is not recommended.

## SAFETY MESSAGES

### Warnings (⚠)

Procedures and instructions in this section that raise potential safety issues are indicated by a warning symbol (⚠). Refer to the following warning messages before performing an operation preceded by this symbol.

#### WARNING

- Explosions can result in serious injury or death. Before connecting a communicator in an explosive atmosphere, make sure the instruments in the loop are installed in accordance with intrinsically safe or nonincendiary field wiring practices.
- Toxic processes can result in serious injury or death. Transmitter can contain residue process. Use appropriate safety precautions when opening drain vents or disconnecting a transmitter from a process.
- DO NOT attempt to loosen drain vent valves or disconnect the transmitter from the process without taking precautionary measures.
- Install and tighten all four process adapter bolts or drain vent valves before applying pressure.
- Both transmitter covers must be fully engaged to meet explosion-proof requirements.

## RETROFITTING OVERVIEW

The procedure for retrofitting a transmitter is divided into three parts:

1. Removing the analog electronics assembly.
2. Installing the smart electronics kit.
3. Characterizing the retrofitted transmitter.

Two tools are required to remove the analog electronics and to install the smart electronics:

- Flat-bladed screwdriver
- ¼-in. nut driver or wrench

The following equipment is needed to characterize the retrofitted transmitter:

- A Rosemount Model 275 or Model 268 HART Communicator with SMART FAMILY® Interface
- An accurate pressure source, preferably 0.025% accuracy or better
- A 250 ohm resistor

The Smart Retrofit Kit, P/N 01151-0935-0001, contains the following items:

| Quantity | Description               |
|----------|---------------------------|
| 1        | Smart electronic assembly |
| 1        | Electronics cover         |
| 1        | Cover O-ring              |
| 2        | Terminal eyelets          |
| 2        | Board spacers             |
| 2        | Standoffs                 |

## REMOVING THE ANALOG ELECTRONICS ASSEMBLY

### ⚠ CAUTION

Use proper earth grounding techniques when handling the smart electronics assembly. The smart electronics assembly is potentially sensitive to electric static discharge.

The vast majority of installed Model 1151 Transmitters have either “E” (4–20 mA linear) or “J” (4–20 mA square root) output codes. The transmitter output code is part of the model number on the transmitter nameplate. It is the eighth character from the left for AP, DP, GP, and HP, and LT transmitters.

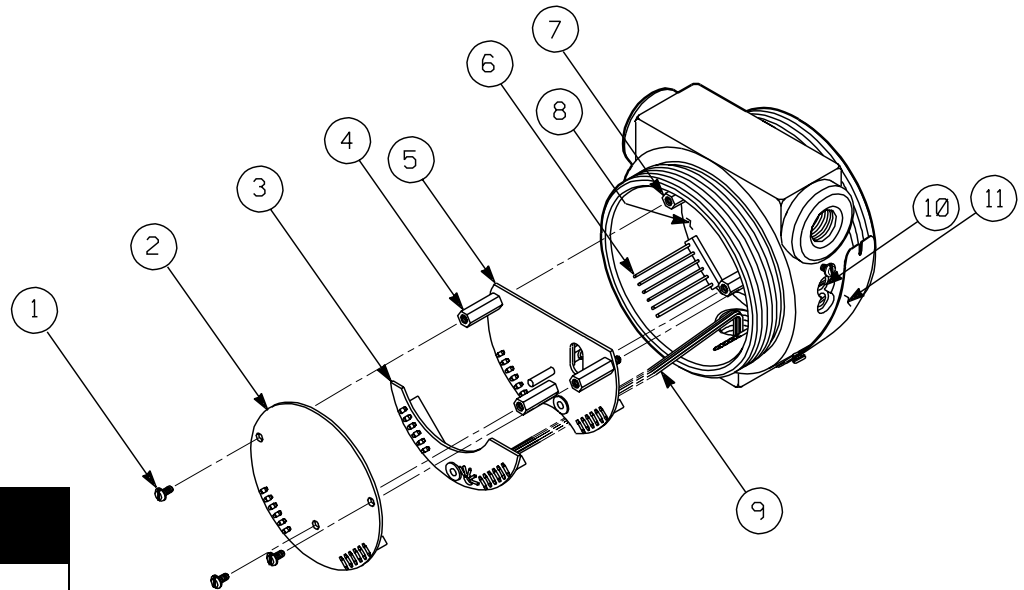
**Example:** (1151DP4 **E** 12M1)

The following steps describe how to remove the analog electronics assembly from transmitters with “E” or “J” output codes for smart retrofitting. However, they can also be used as guidelines for retrofitting transmitters with “A” or “C” output codes. This process requires opening the electronics compartment on the circuit side of the transmitter and removing the amplifier or amplifier/squaring assembly, standoffs, and the calibration board.

### NOTE

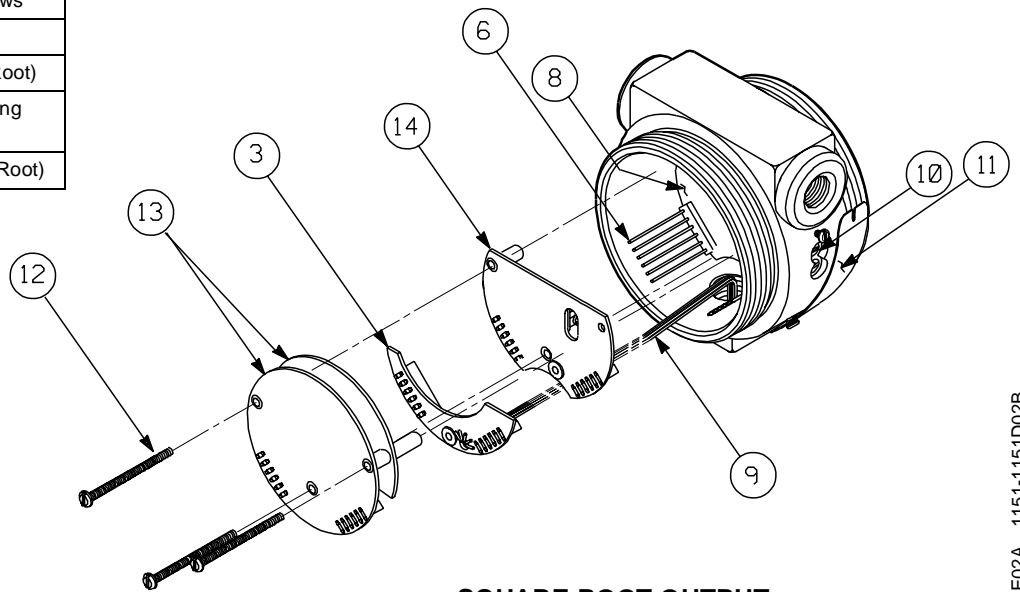
Numbers in parentheses indicate parts shown in Figure C-1.

FIGURE C-1. Model 1151 Analog Electronics.



**LINEAR OUTPUT**

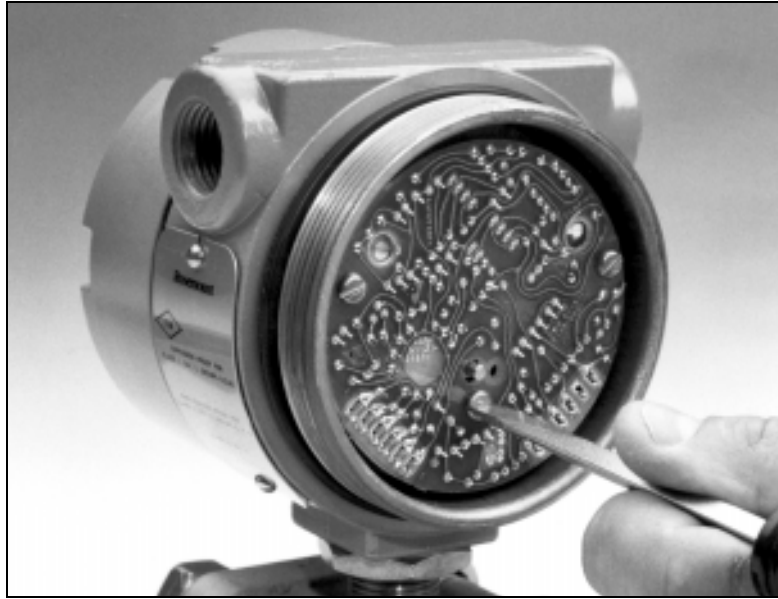
| Ref. No. | Part Description                                    |
|----------|---|
| 1        | Retainer Screws (Linear)                            |
| 2        | Amplifier Board (Linear)                            |
| 3        | Header Board Assembly                               |
| 4        | Standoff Screws (Linear)                            |
| 5        | Calibration Board (Linear)                          |
| 6        | Bayonet Connector Pins                              |
| 7        | Standoff Screws (Linear)                            |
| 8        | Sensor Module Electronics                           |
| 9        | Wiring  |
| 10       | Zero and Span Adjust Screws                         |
| 11       | Housing Cover                                       |
| 12       | Retainer Screws (Square Root)                       |
| 13       | Two-board Amplifier/Squaring Assembly (Square Root) |
| 14       | Calibration Board (Square Root)                     |



**SQUARE ROOT OUTPUT**

1151-1151E02A 1151-1151D02B

1. Ensure that power is removed from the transmitter before beginning the retrofit procedure.
2. Remove the cover from the circuit side of the transmitter.
3. Remove the three retainer screws (1 or 12).



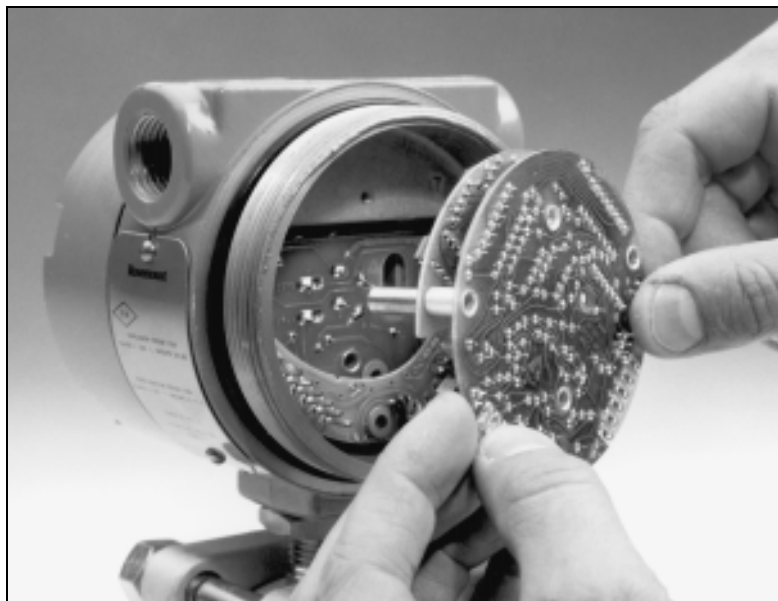
1151-006AB



4. Pull the amplifier board (2) or amplifier/squaring assembly (13) directly off the bayonet connectors (6).



1151-006AB



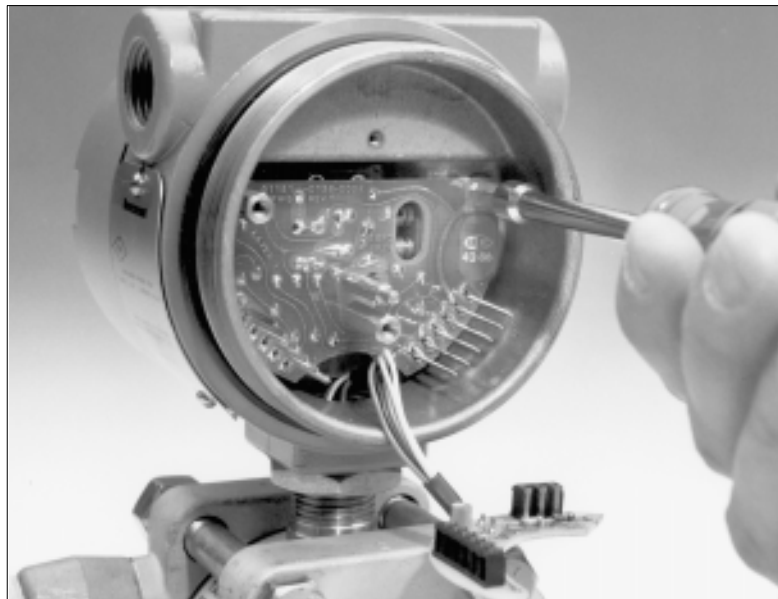
1151-007AB

5. Pull the header board assembly (3) off the bayonet connectors. The header board must be reinserted. Do not cut the wires (9) or remove the header board.



1151-008AB

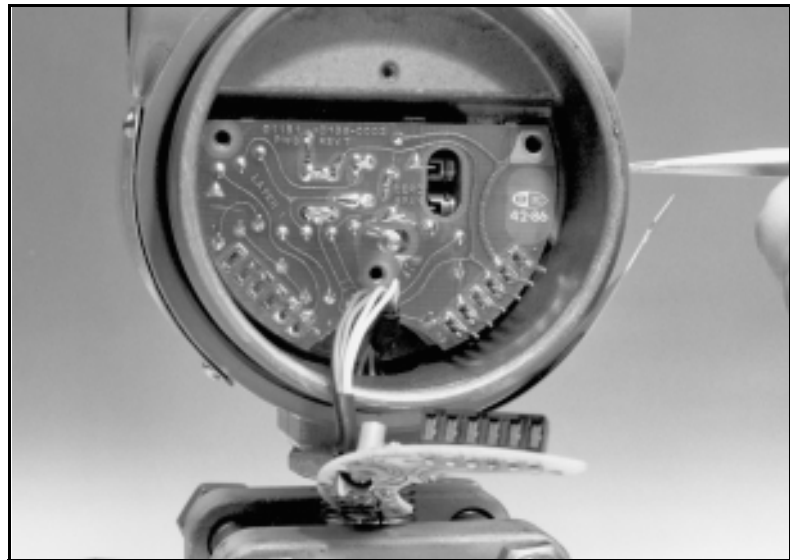
6. If the transmitter has linear output electronics, remove the three standoffs (4). Use a 1/4-in. nut driver or wrench.



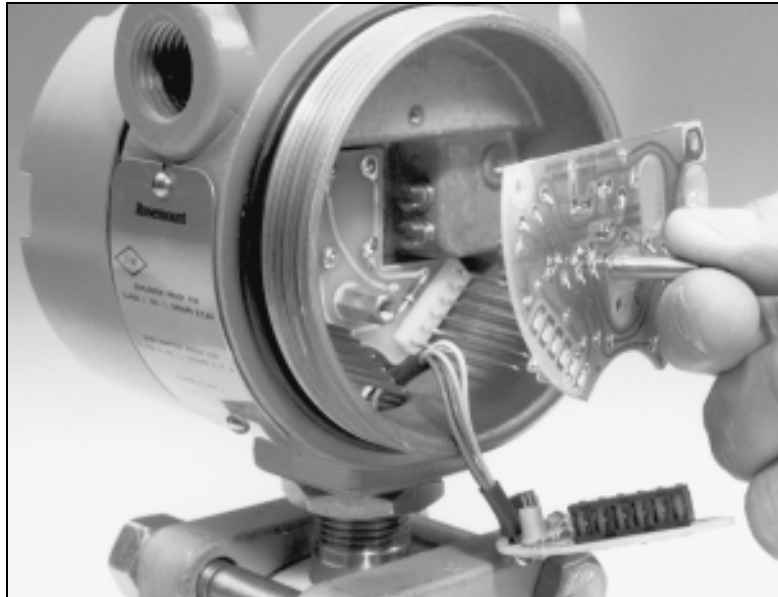
1151-009AB



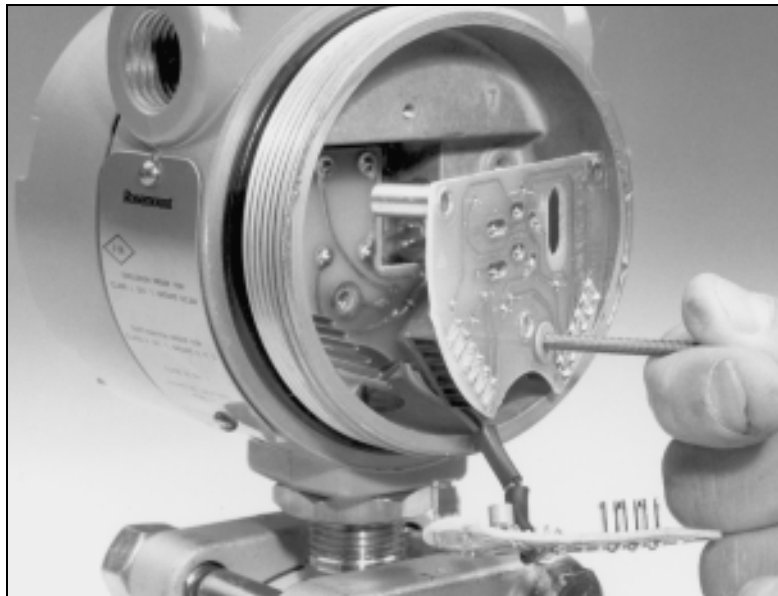
7. Align the zero and span adjust screws (10) so that the potentiometer blades are perpendicular to the board.



8. For linear output models, grip the calibration board (5) by the interface pin. For square root output modes insert a retainer screw into the threaded rivet for use as a handle. Pull out the calibration board. (Removing the calibration board disables the conventional zero and span screws.)

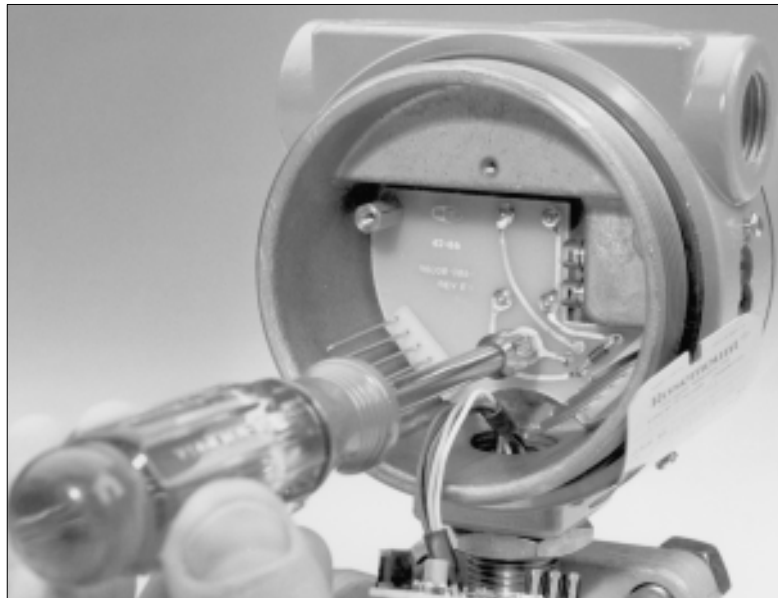


1151-011AB



1151-012AB

Insert the standoffs (7), if necessary. The transmitter is now ready to receive the plug-in smart electronics assembly.



1151-013AB

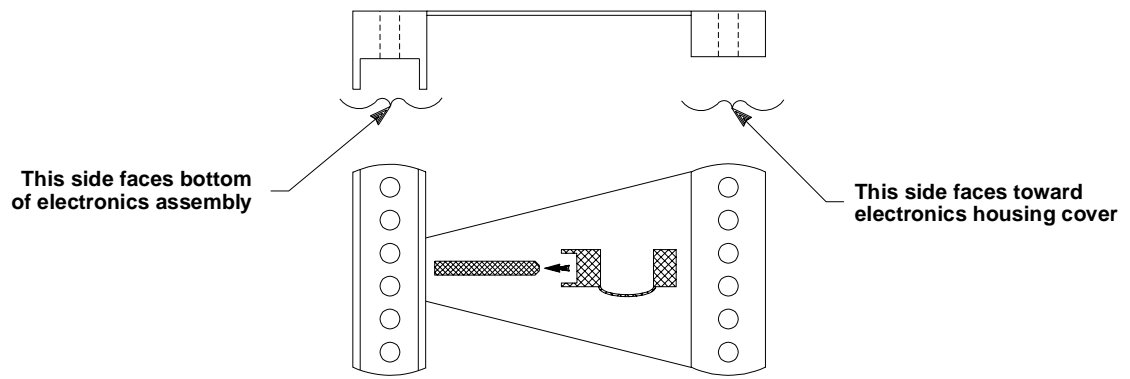
## INSTALLING THE SMART RETROFIT KIT

Installing the smart retrofit electronics kit in the transmitter requires installing plastic spacers to accommodate the retrofit kit and securing the retrofit electronics. After the retrofit kit has been installed, it is necessary to attach eyelets to the terminal side of the transmitter. The eyelets enable hook-up with a HART-based communicator (see Figure C-2).

**⚠ CAUTION**

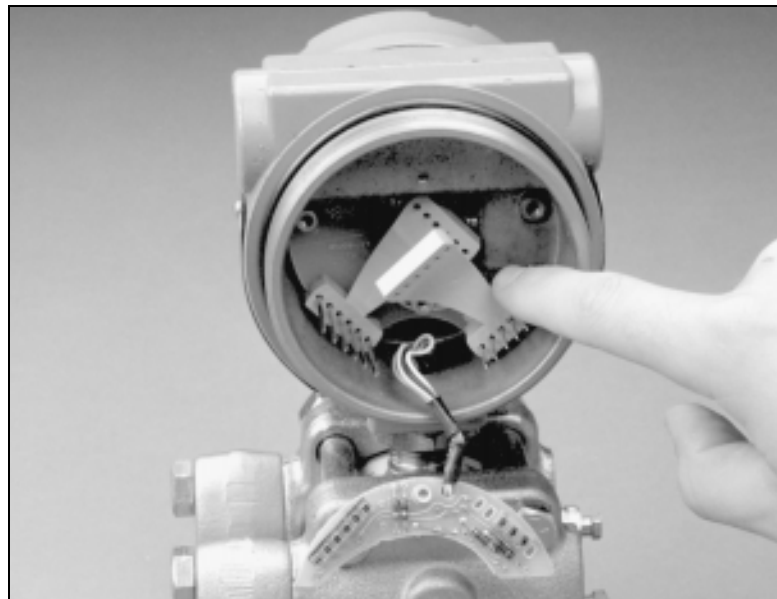
Use proper earth grounding techniques when handling the smart electronics assembly. The smart electronics assembly is potentially sensitive to electric static discharge.

FIGURE C-2. Spacer Assembly.



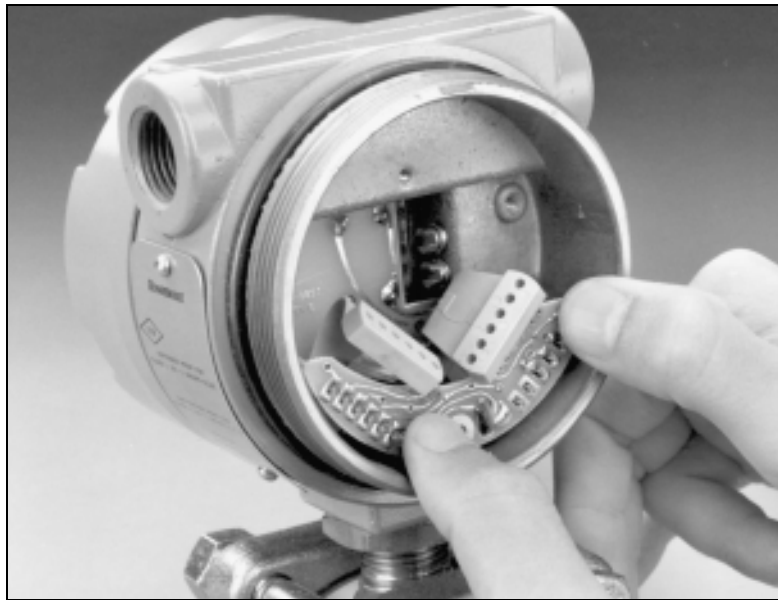
1151-0763A01B

1. Slide the bottom half of one spacer over one of the rows of bayonet connectors. Then repeat the procedure for the other row.



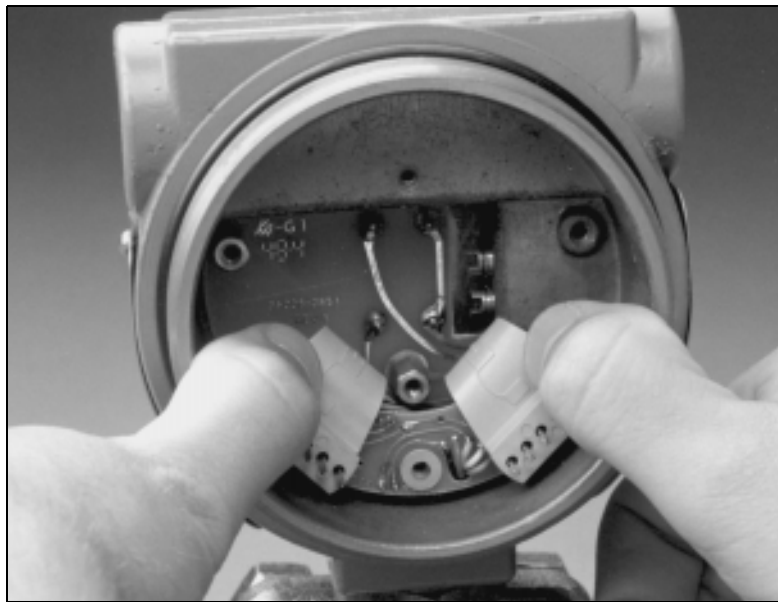
1151-014AB

2. Align the header board with the bayonet connector pins, and slide the header board halfway down the pins.



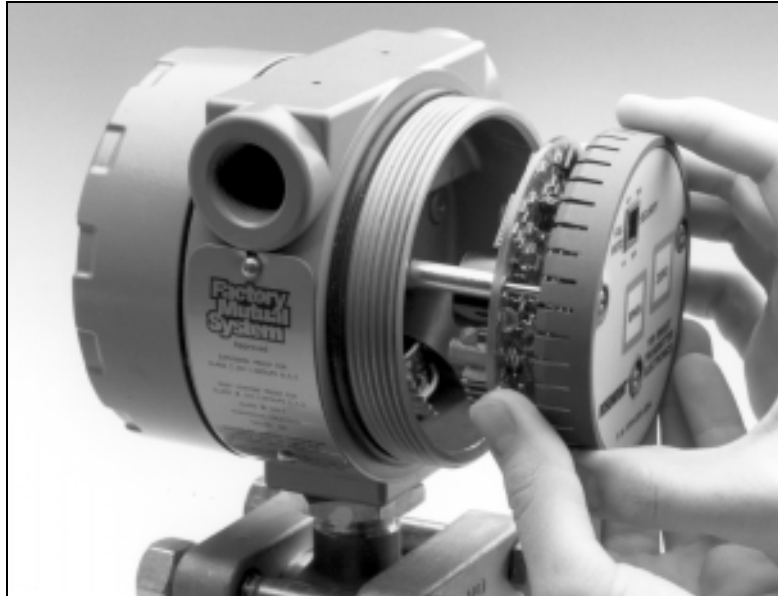
1151-015AB

3. Align the tops of both spacers with the bayonet connector pins, and slide them down the pins, pushing firmly on both the spacers and the header board to seat the board.



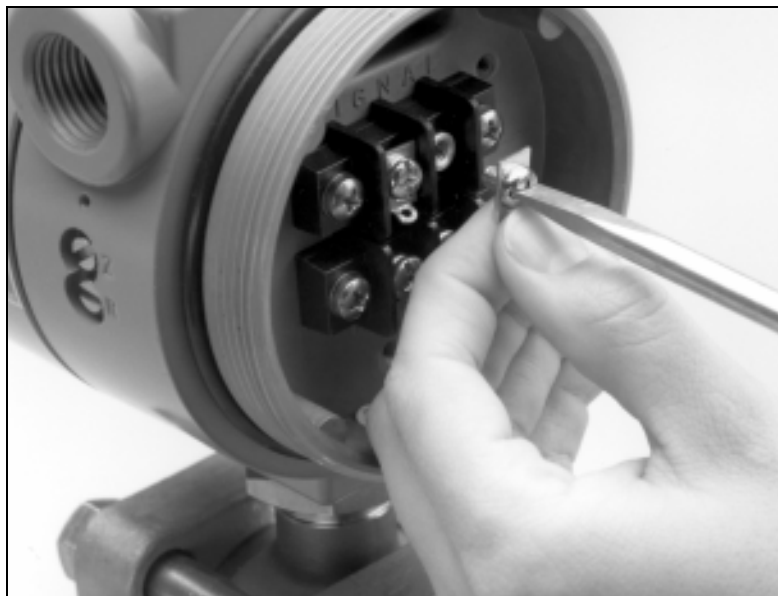
1151-016AB

4. Align the smart electronics assembly with the bayonet connector pins, making sure all pins line up with the proper receptacles. Next, push the assembly slowly inward until it is fully seated.



1151-017AB

5. Tighten the three captive screws on the smart electronics assembly to secure it in place.
6. Attach the electronics cover provided in the smart retrofit kit, and tighten securely.
7. Remove the cover from the terminal side of the transmitter. Two eyelets that fit under the + and – signal terminal screws are provided to facilitate connections to HART-based communicator. The signal terminal is the upper block as indicated on the transmitter housing.
8. Remove the signal terminal + and – screws. Attach an eyelet to each screw, and reinsert the screws.



1151-020BB

9. Reattach the cover on the terminal side, and tighten securely.



## CHARACTERIZATION

The transmitter is now ready to be characterized. Characterization is a one-time calibration of the sensor in the Model 1151 Transmitter. During characterization, known pressures are applied to the sensor, and corresponding digital values are stored in the EEPROM located in the smart transmitter electronics. The microprocessor uses these values to make linearization corrections. The digital-to-analog converter then converts the corrected digital signal into a 4–20 mA dc output. The Model 1151 Transmitter will stay in high alarm (approximately 22 mA output) until the characterization sequence is completed.




---

### NOTE

The transmitter must be re-characterized if either the sensor module or the smart transmitter electronics are repaired or replaced.

---

### Before Characterizing the Transmitter

1. Be prepared to answer the following questions:
  - Module type (AD, DP, HP, LT) on the transmitter S/N tag?
  - Module range on the transmitter module tag?
  - Pressure units on your pressure source?
  - Serial number on the transmitter S/N tag?
-  2. Connect the pressure source.
-  3. Remove the terminal side cover of the Model 1151 Smart Pressure Transmitter.
-  4. Connect power supply leads to the terminal block. Apply power to the transmitter.


---

### NOTE

Failure to use accurate equipment may result in a transmitter that cannot meet its accuracy specification.

---

### Characterizing with a Model 275 Communicator

-  1. Connect the Rosemount Model 275 HART communicator electrical connections to the SIGNAL terminal block. The Model 275 connections are not polarity sensitive.
2. Turn the Model 275 on by pushing the I/O button.
3. Follow the Model 275 menus to characterize:
  - Device setup
  - Detailed setup
  - Sensor
  - Pressure sensor
  - Sensor service
  - Characterize
4. Follow the instructions on the screen.
5. Verify the new transmitter configuration:
  - Tag
  - Range points
  - Linear/square root
  - Damping
6. Verify that the Fail Safe Mode Switch and the Transmitter Security Switch on the smart electronics circuit board are correct.
7. Attach the electronics cover and tighten.
8. Put the transmitter back in service.



## Characterization with a Model 268 Communicator



1. Connect the Rosemount Model 268 HART Communicator electrical connections to the SIGNAL terminal block. The Model 268 connections are not polarity sensitive.
2. Turn the Model 268 on by pushing the I/O button.
3. Follow the Model 268 menus to characterize:
  - Proceed
  - Format
  - Proceed
  - Charize
4. Follow the instructions on the screen.
5. Verify the new transmitter configuration:
  - Tag
  - Range points
  - Linear/square root
  - Damping
6. Verify that the Fail Safe Mode Switch and the Transmitter Security Switch on the smart electronics circuit board are correct.
7. Attach the electronics cover and tighten.
8. Put the transmitter back in service.





---

## **Approval Drawings**

Index of intrinsically safe barrier systems and entity parameters for Models 444, 1135, 1144, 1151, and 2051 transmitters and Model 751 Field Indicators (Drawing Number 01151-0214, Rev. U), pages D-2 through D-7.

Index of intrinsically safe C.S.A. barrier systems for Model 1151 transmitters (Drawing Number 01151-2575, Rev. C), pages D-8 through D-10.

Index of intrinsically safe barrier systems and entity parameters for the Model 268 SMART FAMILY Interface (Drawing Number 00268-0031, Rev M), pages D-11 through D-17.

Index of intrinsically safe barrier systems and entity parameters for the Model 275 HART Communicator (Drawing Number 00275-0081, Rev B), pages D-18 through D-23.

Index of intrinsically safe C.S.A. barrier systems for the Model 275 HART Communicator (Drawing Number 00275-0082, Rev A), page D-24.

| REVISIONS |   |        |        |      |          |
|-----------|---|--------|--------|------|----------|
| LTR       | DESCRIPTION   | ECO NO | REV BY | APPR | DATE     |
| P         | Change entity parameters (Fm on re-exam) correct 444 CI | 637376 | WKR    | WKR  | 9/24/90  |
| R         | Add 1151 Low Power Barrier System, Model 751 LI to 0    | 638105 |        | WKR  | 4/27/90  |
| T         | 1135, 1144, 1151 LI TO $\emptyset$                      | 639039 | SVC    | WKR  | 1/23/91  |
| U         | 1151 LI TO 20; CI .01 AND .034                          | 651426 | SVC    | ADT  | 12/11/92 |
| V         | 751 LI TO $\emptyset$                                   | 662242 |        | QSE  | 11/17/94 |

| CONTENTS            |                 |
|---------------------|-----------------|
| ENTITY APPROVALS    | SHEETS 2 THRU 4 |
| APPROVED PARAMETERS | SHEETS 2 THRU 3 |
| CONNECTION DIAGRAMS | SHEET 4         |

# MASTER

| APPROVED SOURCES OF SUPPLY |             |
|----------------------------|-------------|
| MFG                        | MFG PART NO |
|                            |             |
|                            |             |
|                            |             |

Material purchased to this Rosemount Specification Control Drawing shall be required to meet all the specifications of this drawing. Any mention of manufacturer's part number within this drawing is for reference only. This is necessary to ensure design control of Rosemount's end product. It is Rosemount's intent to purchase your standard material whenever possible.

## SPECIFICATION CONTROL DRAWING

|   |                                       |                         |   |
|---|---------------------------------------|-------------------------|---|
| UNLESS OTHERWISE SPECIFIED, DIMENSIONS ARE IN INCHES.<br><br>TOLERANCES:<br><br>DECIMALS    FRACTIONS<br>X ± .1        ± 1/32<br>XX ± .02     ANGLES<br>XXX ± .010   ± 2° | PREPARED BY:<br><i>Nancy Nix</i>      | DATE:<br><i>9/24/90</i> | <b>ROSEMOUNT</b> ®<br>Measurement<br>Control<br>Analytical<br>Valves  |
|   | CHECKED BY:<br><i>WKR</i>             |                         |   |
|   | APPROVED BY Q.C.<br>_____             |                         | TITLE:<br>INDEX OF INTRINSICALLY SAFE BARRIER SYSTEMS & ENTITY PARAMETERS FOR 444, 1135, 1144, 1151, & 2051 TRANSMITTERS AND 751 FIELD INDICATORS |
|   | APPROVED BY ENG.<br><i>N. C. Baum</i> | DATE:<br><i>4/26/91</i> | SIZE    CODE    IDENT NO    DRAWING NO<br>A        04274        01151-0214  |
|   | APPROVED BY PURCH.<br>_____           |                         | SCALE None    U/M: Each    SHEET 1 OF 1   |
| FINAL APPROVAL ES<br>_____  |                                       |                         |   |

## ENTITY CONCEPT APPROVALS

The entity concept allows interconnection of intrinsically safe apparatus to associated apparatus not specifically examined in combination as a system. The approved values of maximum open circuit voltage ( $V_{OC}$  or  $V_T$ ) and maximum short circuit current ( $I_{SC}$  or  $I_T$ ) for the associated apparatus must be less than or equal to the maximum safe input voltage ( $V_{MAX}$ ) and input current ( $I_{MAX}$ ) of the intrinsically safe apparatus. In addition, the approved maximum allowable connected capacitance ( $C_A$ ) and inductance ( $L_A$ ) of the associated apparatus must be greater than the maximum unprotected internal capacitance ( $C_I$ ) and inductance ( $L_I$ ) of the intrinsically safe apparatus. The approved entity concept parameters are as follows:

**Model 444**

Class I, Div. 1, Groups A and B

$V_{MAX} = 40V$

$I_{MAX} = 165 \text{ mA}$

$C_I = 0.044\mu F$

$L_I = 0$

$V_{OC}$  or  $V_T$  is less than or equal to 40V

$I_{SC}$  or  $I_T$  is less than or equal to 165 mA

$C_A$  is greater than 0.0441F

$L_A$  is greater than 0

Class I, Div. 1, Groups C and D

$V_{MAX} = 40V$

$I_{MAX} = 225 \text{ mA}$

$C_I = 0.044\mu F$

$L_I = 0$

$V_{OC}$  or  $V_T$  is less than or equal to 40V

$I_{SC}$  or  $I_T$  is less than or equal to 225 mA

$C_A$  is greater than 0.0441F

$L_A$  is greater than 0

**Model 751**

Class I, Div. 1, Groups A and B

$V_{MAX} = 40V$

$I_{MAX} = 165 \text{ mA}$

$C_I = 0$

$L_I = 0$

$V_{OC}$  or  $V_T$  is less than or equal to 40V

$I_{SC}$  or  $I_T$  is less than or equal to 165 mA

$C_A$  is greater than 0

$L_A$  is greater than 0

Class I, Div. 1, Groups C and D

$V_{MAX} = 40V$

$I_{MAX} = 225 \text{ mA}$

$C_I = 0$

$L_I = 0$

$V_{OC}$  or  $V_T$  is less than or equal to 40V

$I_{SC}$  or  $I_T$  is less than or equal to 225 mA

$C_A$  is greater than 0

$L_A$  is greater than 0

|   |  |                  |           |                                  |
|---|--|------------------|-----------|----------------------------------|
| <b>Rosemount Inc.</b><br>MINNEAPOLIS, MINNESOTA |  | SIZE<br><b>A</b> | FSCM. NO. | DRAWING NO.<br><b>01151-0214</b> |
| DR.   |  | SCALE: NONE      | WT.       | SHEET <b>2</b> OF <b>6</b>       |
| ISSUE   |  |                  |           |                                  |

# MASTER

## Model and 1151

Class I, Div. 1, Groups A and B

$V_{MAX} = 40V$   
 $I_{MAX} = 165\text{ mA}$   
 $C_I(1151\text{ Std}) = 0$   
 $C_I(\text{Smart } 1151) = 0.024\mu F$   
 $C_I(1151\text{ Std w/R Option}) = 0.010\mu F$   
 $C_I(1151\text{ Smart w/R\_Option}) = 0.034\mu F$   
 $L_I(1151\text{ Std}) = 0$   
 $L_I(1151\text{ w/R\_Option}) = 20\mu H$

$V_{OC}$  or  $V_T$  is less than or equal to 40V  
 $I_{SC}$  or  $I_T$  is less than or equal to 165 mA  
 $C_A$  is greater than 0  
 $C_A$  is greater than  $0.024\mu F$   
 $C_A$  is greater than  $0.010\mu F$   
 $C_A$  is greater than  $0.034\mu F$   
 $L_A$  is greater than 0  
 $L_A$  is greater than  $20\mu H$

Class I, Div. 1, Groups C and D

$V_{MAX} = 40V$   
 $I_{MAX} = 225\text{ mA}$   
 $C_I(1151\text{ Std}) = 0$   
 $C_I(\text{Smart } 1151) = 0.024\mu F$   
 $C_I(1151\text{ Std w/R Option}) = 0.010\mu F$   
 $C_I(1151\text{ Smart w/R\_Option}) = 0.034\mu F$   
 $L_I(1151\text{ Std}) = 0$   
 $L_I(1151\text{ w/R\_Option}) = 20\mu H$

$V_{OC}$  or  $V_T$  is less than or equal to 40V  
 $I_{SC}$  or  $I_T$  is less than or equal to 225 mA  
 $C_A$  is greater than 0  
 $C_A$  is greater than  $0.024\mu F$   
 $C_A$  is greater than  $0.010\mu F$   
 $C_A$  is greater than  $0.034\mu F$   
 $L_A$  is greater than 0  
 $L_A$  is greater than  $20\mu H$

## Model 2051

Class I, Div. 1, Groups A and B

$V_{MAX} = 40V$   
 $I_{MAX} = 165\text{ mA}$   
 $C_I = 0.012\mu F$   
 $L_I = 480\mu H$

$V_{OC}$  or  $V_T$  is less than or equal to 40V  
 $I_{SC}$  or  $I_T$  is less than or equal to 165 mA  
 $C_A$  is greater than  $0.012\mu F$   
 $L_A$  is greater than  $480\mu H$

Class I, Div. 1, Groups C and D

$V_{MAX} = 40V$   
 $I_{MAX} = 225\text{ mA}$   
 $C_I = 0.012\mu F$   
 $L_I = 480\mu H$

$V_{OC}$  or  $V_T$  is less than or equal to 40V  
 $I_{SC}$  or  $I_T$  is less than or equal to 225 mA  
 $C_A$  is greater than  $0.012\mu F$   
 $L_A$  is greater than  $480\mu H$

|   |  |                         |           |                                  |
|---|--|-------------------------|-----------|----------------------------------|
| <b>Rosemount Inc.</b><br>MINNEAPOLIS, MINNESOTA |  | <b>SIZE</b><br><b>A</b> | FSCM. NO. | DRAWING NO.<br><b>01151-0214</b> |
| DR.   |  |                         |           |                                  |
| ISSUE   |  | SCALE: NONE             | WT.       | SHEET 3 OF 6                     |

**Model 1135**

Class I, Div. 1, Groups A and B

$V_{MAX} = 40V$

$I_{MAX} = 165 \text{ mA}$

$C_I = 0.008\mu F$

$L_I = 0$

 $V_{OC}$  or  $V_T$  is less than or equal to 40V $I_{SC}$  or  $I_T$  is less than or equal to 165 mA $C_A$  is greater than 0.008IF $L_A$  is greater than 0

Class I, Div. 1, Groups C and D

$V_{MAX} = 40V$

$I_{MAX} = 225 \text{ mA}$

$C_I = 0.008\mu F$

$L_I = 0$

 $V_{OC}$  or  $V_T$  is less than or equal to 40V $I_{SC}$  or  $I_T$  is less than or equal to 225 mA $C_A$  is greater than 0.008IF $L_A$  is greater than 0**Model 1144**

Class I, Div. 1, Groups A and B

$V_{MAX} = 40V$

$I_{MAX} = 165 \text{ mA}$

$C_I = 0$

$L_I = 0$

 $V_{OC}$  or  $V_T$  is less than or equal to 40V $I_{SC}$  or  $I_T$  is less than or equal to 165 mA $C_A$  is greater than 0 $L_A$  is greater than 0

Class I, Div. 1, Groups C and D

$V_{MAX} = 40V$

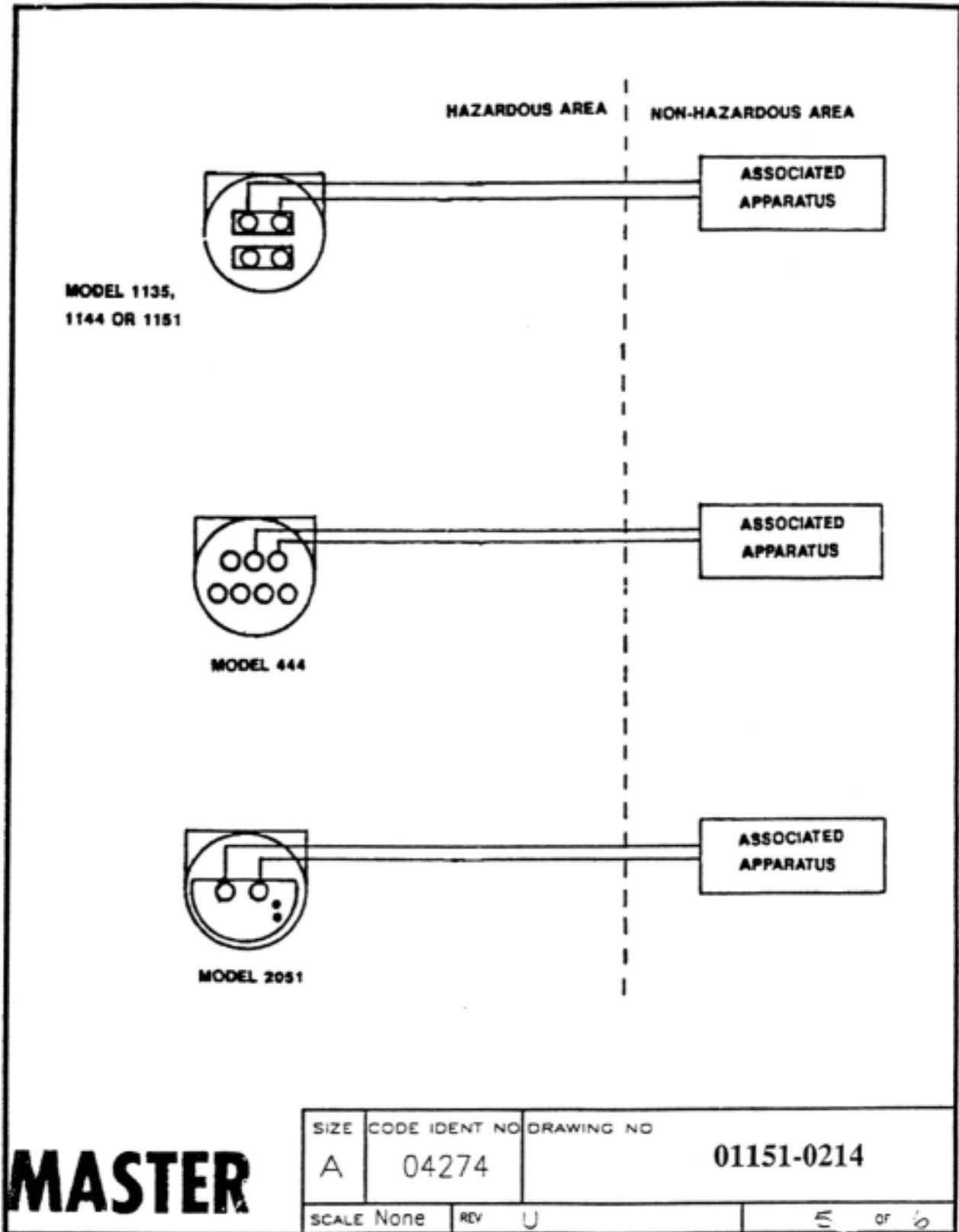
$I_{MAX} = 225 \text{ mA}$

$C_I = 0$

$L_I = 0$

 $V_{OC}$  or  $V_T$  is less than or equal to 40V $I_{SC}$  or  $I_T$  is less than or equal to 225 mA $C_A$  is greater than 0 $L_A$  is greater than 0**MASTER**

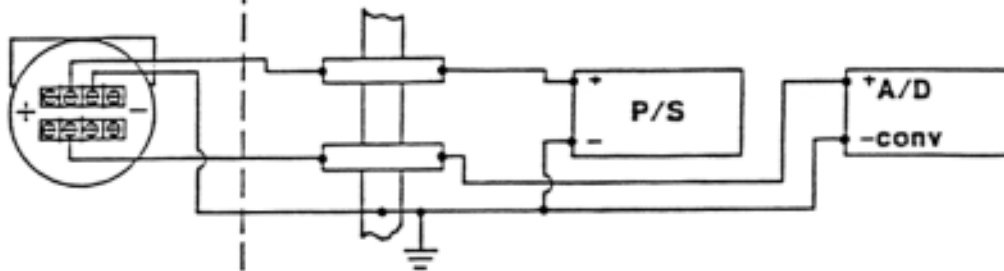
|   |  |                  |           |                                  |
|---|--|------------------|-----------|----------------------------------|
| <b>Rosemount Inc.</b><br>MINNEAPOLIS, MINNESOTA |  | SIZE<br><b>A</b> | FSCM. NO. | DRAWING NO.<br><b>01151-0214</b> |
| DR.   |  | SCALE: NONE      | WT.       | SHEET <b>4</b> OF <b>6</b>       |
| ISSUE   |  |                  |           |                                  |



1151 --- L & M CIRCUIT CONNECTION WITH INTRINSIC SAFETY BARRIERS

HAZARDOUS AREA

NON-HAZARDOUS AREA

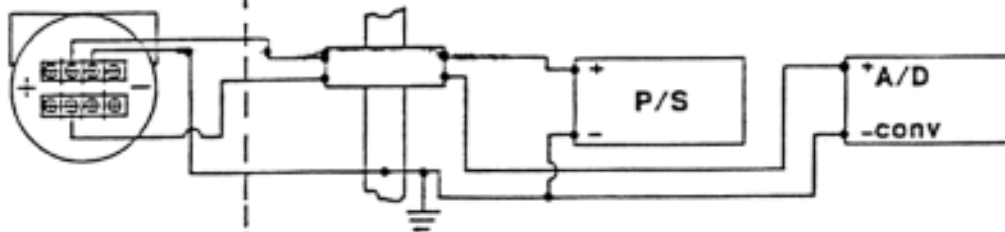


Two Single Channel Barriers

CIRCUIT DIAGRAM 1  
 (ONLY FOR USE WITH BARRIERS APPROVED IN THIS CONFIGURATION)

HAZARDOUS AREA

NON-HAZARDOUS AREA



One Dual Channel Barrier

CIRCUIT DIAGRAM 2

MASTER

|            |               |            |
|------------|---------------|------------|
| SIZE       | CODE IDENT NO | DRAWING NO |
| A          | 04274         | 01151-0214 |
| SCALE NONE | REV U         | c OF 6     |

| PROPRIETARY INFORMATION IS CONTAINED HEREIN AND MUST BE HANDLED ACCORDINGLY<br>BY _____ DATE _____ | REVISIONS                     |                       |               |               |          |
|--|-------------------------------|-----------------------|---------------|---------------|----------|
|  | REV                           | DESCRIPTION           | CHG. NO.      | APP'D         | DATE     |
|  | A                             | NEW RELEASE           | 646666        | <b>W.C.R.</b> | 04/01/92 |
|  | B                             | 150 ohms was 120 ohms | 650816        | <b>J.J.B.</b> | 11/13/92 |
| C  | 150 ohms was 120 ohms (SHT 3) | 652195                | <b>J.J.B.</b> | 1/29/93       |          |

## CSA INTRINSICALLY SAFE APPROVAL

Exia

Intrinsically Safe /Securite Intrinsic

THE ROSEMOUNT MODEL 1151 PRESSURE TRANSMITTER IS APPROVED BY CSA AS INTRINSICALLY SAFE FOR THE CLASS I, DIVISION 1 GROUPS AS INDICATED WHEN USED WITH THE BARRIERS AND CONVERTERS LISTED BELOW AND CONNECTED AS SHOWN IN THE ACCOMPANYING DIAGRAMS.

| DEVICE  | PARAMETERS  | APPROVED FOR CLASS I, DIV. 1 |
|---|---|------------------------------|
| CSA Approved Safety Barrier   | $\left. \begin{array}{l} 30 \text{ V or less} \\ 330 \text{ ohms or more} \\ \\ 28 \text{ V or less} \\ 300 \text{ ohms or more} \\ \\ 22 \text{ V or less} \\ 180 \text{ ohms or more} \end{array} \right\}$ | Groups A, B, C, D            |
| Foxboro Converter<br>2AS-131-CGB, 3AD-131A CS-E / CGB-A,<br>2AI-13V-CGB, 3A2-13D CS-E / CGB-A,<br>2AI-12V-CGB, 3A2-12D CS-E / CGB-A,<br>2AS-121-CGB, 3A4-12DA CS-E / CGB-A,<br>3F4-12DA1 CS-E / CGB-A |   | Groups B, C, D               |
| CSA Approved Safety Barrier   | $\left. \begin{array}{l} 30 \text{ V or less} \\ 150 \text{ ohms or more} \end{array} \right\}$   | Groups C, D                  |

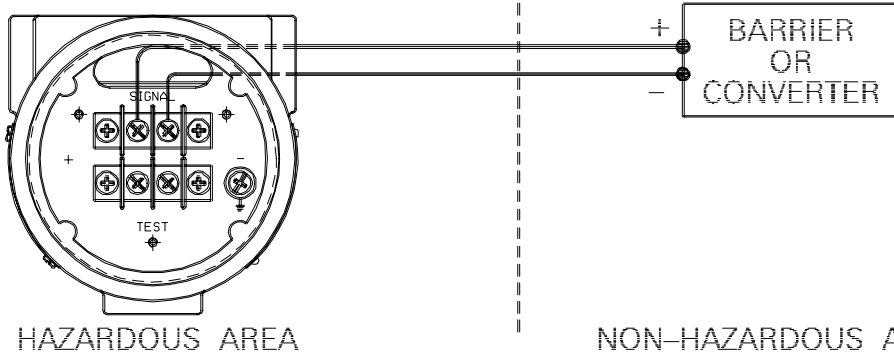
THIS DRAWING WAS CREATED ON CAD. DRAWING IS ARCHIVED ON MAGNETIC TAPE FOR ECO CHANGES.

|   |                                  |   |   |  |  |                  |           |                            |                   |
|---|----------------------------------|---|---|--|--|------------------|-----------|----------------------------|-------------------|
| UNLESS OTHERWISE SPECIFIED DIMENSIONS IN INCHES. REMOVE ALL BURRS AND SHARP EDGES. MACHINE SURFACE FINISH 125<br>- TOLERANCES -<br><br>DECIMALS    FRACTIONS<br>.X±.1        ±1/32<br>.XX±.02     ANGLES<br>.XXX±.010   ±2° | CONTRACT NO.                     | <b>ROSEMOUNT</b> <sup>®</sup> Measurement Control Analytical Valves<br>Rosemount Inc.<br>12001 Technology Drive<br>Eden Prairie, MN 55344 USA | TITLE INDEX OF CSA INTRINSICALLY SAFE BARRIER SYSTEMS FOR MODEL 1151 TRANSMITTERS |  |  |                  |           |                            |                   |
|   | DR. <b>S.CAPPAUL</b> 03/18/92    |   |   |  |  | SIZE <b>A</b>    | FSCM NO   | DWG NO.                    | <b>01151-2575</b> |
|   | CHK'D <b>W.C.RAUTH</b> 04/01/92  |   |   |  |  | SCALE <b>N/A</b> | WT. _____ | SHEET <b>1</b> OF <b>3</b> |                   |
|   | APP'D. <b>W.C.RAUTH</b> 04/01/92 |   |   |  |  | APP'D. GOVT.     |           |                            |                   |
| DO NOT SCALE PRINT  |                                  |   |   |  |  |                  |           |                            |                   |

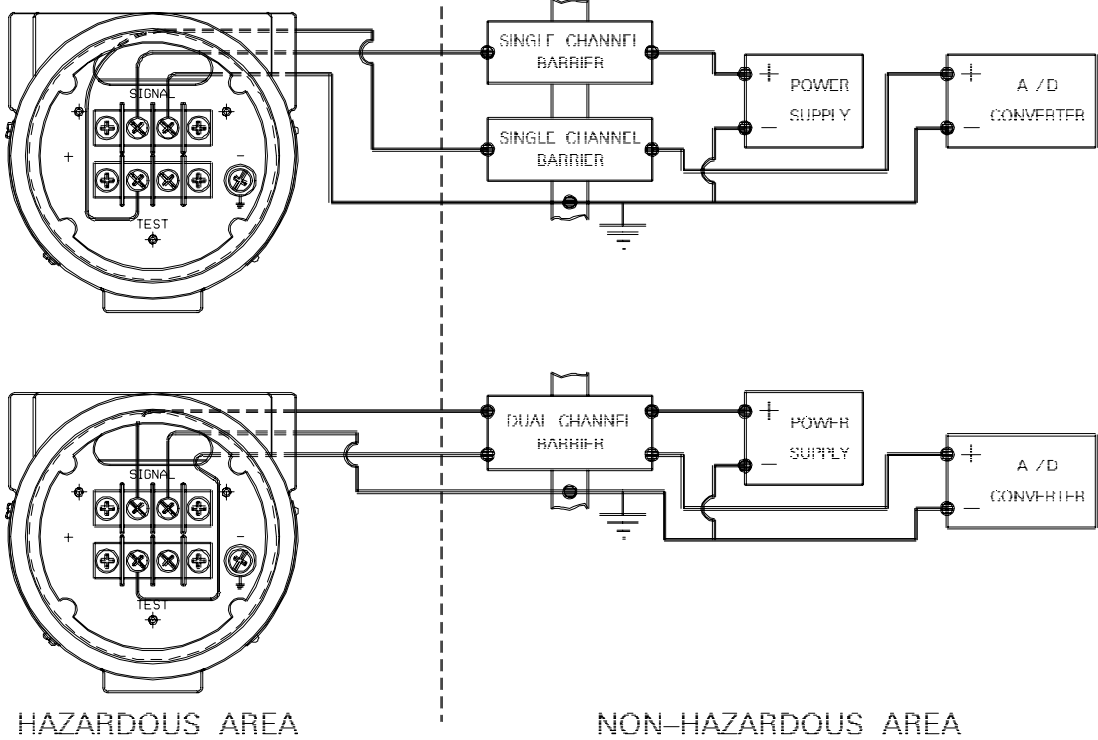


| REVISIONS |             |          |       |      |
|-----------|-------------|----------|-------|------|
| REV       | DESCRIPTION | CHG. NO. | APP'D | DATE |
| C         |             | 652195   |       |      |

MODEL 1151 CIRCUIT CONNECTION WITH BARRIER OR CONVERTER



MODEL 1151\_\_L, M CIRCUIT CONNECTION WITH BARRIER(S)



Rosemount Inc.  
12001 Technology Drive  
Eden Prairie, MN 55344 USA

DR. **S. CAPAUL** 03/18/92

ISSUED

THIS DRAWING WAS CREATED ON CAD. DRAWING IS ARCHIVED ON MAGNETIC TAPE FOR ECO CHANGES.

|          |         |         |                   |        |
|----------|---------|---------|-------------------|--------|
| SIZE     | FSCM NO | DWG NO. | <b>01151-2575</b> |        |
| <b>A</b> |         |         | SCALE             | NONE   |
| WT.      |         | SHEET   |                   | 2 OF 3 |

| REVISIONS |             |          |       |      |
|-----------|-------------|----------|-------|------|
| REV       | DESCRIPTION | CHG. NO. | APP'D | DATE |
| C         |             | 652195   |       |      |

MODEL 1151\_\_\_L, M CIRCUIT CONNECTION WITH BARRIER(S)  
(CONTINUED)

APPROVED FOR CLASS I, DIVISION 1, GROUPS A, B, C, D WHEN USED IN CIRCUIT WITH TWO CSA APPROVED SINGLE CHANNEL SAFETY BARRIERS; ONE WITH APPROVED SAFETY PARAMETERS OF 28 VOLTS OR LESS AND 300 OHMS OR MORE IN +POWER LINE, AND THE OTHER WITH APPROVED SAFETY PARAMETERS OF 10 VOLTS OR LESS AND 47 OHMS OR MORE IN +OUTPUT LINE.

-OR-

ONE CSA APPROVED DUAL CHANNEL SAFETY BARRIER WITH IDENTICAL APPROVED SAFETY PARAMETERS CONNECTED IN LIKE MANNER.

APPROVED FOR CLASS I, DIVISION 1, GROUPS C, D WHEN USED IN CIRCUIT WITH TWO CSA APPROVED SINGLE CHANNEL SAFETY BARRIERS; ONE WITH APPROVED SAFETY PARAMETERS OF 30 VOLTS OR LESS AND 150 OHMS OR MORE IN +POWER LINE AND THE OTHER WITH APPROVED SAFETY PARAMETERS OF 10 VOLTS OR LESS AND 47 OHMS OR MORE IN +OUTPUT LINE.

|  |                           |
|--|---------------------------|
| Rosemount Inc.<br>12001 Technology Drive<br>Eden Prairie, MN 55344 USA |                           |
| DR.  | <b>S. CAPAUL</b> 03/30/92 |
| ISSUED   |                           |

THIS DRAWING WAS CREATED ON CAD. DRAWING IS ARCHIVED ON MAGNETIC TAPE FOR ECO CHANGES.

|          |         |         |                   |
|----------|---------|---------|-------------------|
| SIZE     | FSCM NO | DWG NO. | <b>01151-2575</b> |
| <b>A</b> |         |         |                   |
| SCALE    | N/A     | WT.     | _____             |
|          |         | SHEET   | 3 OF 3            |

| BY _____ DATE _____ | REVISIONS |                                     |          |               |          |
|---------------------|-----------|-------------------------------------|----------|---------------|----------|
|                     | REV       | DESCRIPTION                         | CHG. NO. | APP'D         | DATE     |
|                     | G         | ADD SHT 4&5, DELETE CLASS II & III. | 636328   | <b>B.S.J.</b> | 08/01/90 |
|                     | H         | ADD 3051 P/L/H, 3001C CL /CH        | 636904   | <b>K.D.V.</b> | 09/06/90 |
|                     | J         | ADD SHT. 6, FIX TBL. 1.             | 638723   | <b>B.S.J.</b> | 01/02/91 |
|                     | K         | ADD 3044C                           | 641710   | <b>W.R.K.</b> | 06/13/91 |
|                     | L         | ADD 3001S & SHT 7 FOR 3051C-LP      | 642380   | <b>G.E.M.</b> | 8/13/91  |
|                     | M         | ADD 3095                            | 653145   | <b>K.D.V.</b> | 4/8/93   |

THE ROSEMOUNT MODEL 268 SMART FAMILY INTERFACE IS APPROVED BY FACTORY MUTUAL AS INTRINSICALLY SAFE FOR THE CLASS I, DIVISION 1 GROUPS INDICATED WHEN USED IN CIRCUIT WITH THE BARRIERS AND CONVERTERS LISTED BELOW AND THE ROSEMOUNT SMART FAMILY TRANSMITTERS DEPICTED IN THE ACCOMPANYING CIRCUIT DIAGRAMS.

| BARRIER MANUFACTURER | MODEL  | APPROVED FOR CLASS I DIVISION 1, GROUPS  |
|----------------------|--|--|
| FOXBORO              | 2AI-I2V-FGB<br>2AI-I3V-FGB<br>2AS-I3I-FGB<br>3A2-I2D-CS-E/FGB-A<br>3A2-I3D-CS-E/FGB-A  | A,B,C,D<br>↓   |
| HONEYWELL            | 38545-000-0110-113-F5B5<br>38545-000-0110-111/112-F5B5   | C,D  |
| MTL                  | 115<br>122<br>322<br>715<br>722  | A,B,C,D<br>↓   |
| R. STAHL             | 8901/31-199/100/7<br>8901/30-199/100/7<br>8901/31-280/165/7<br>8901/30-280/165/7<br>[ 8903/51-200/050/7<br>8901/31-086/150/7<br>[ 8901/31-280/165/7<br>8901/31-086/150/7<br>9005/01-245/060<br>9005/01-252/100 | C,D<br>C,D<br>↓<br>A,B,C,D<br>A,B,C,D<br>C,D<br>C,D<br>↓<br>A,B,C,D<br>A,B,C,D |
| TAYLOR               | 5850FL81200<br>5851FL81200<br>1130FF21000<br>1130FF22000<br>1135FF21000<br>1135FF22000   | C,D<br>↓   |

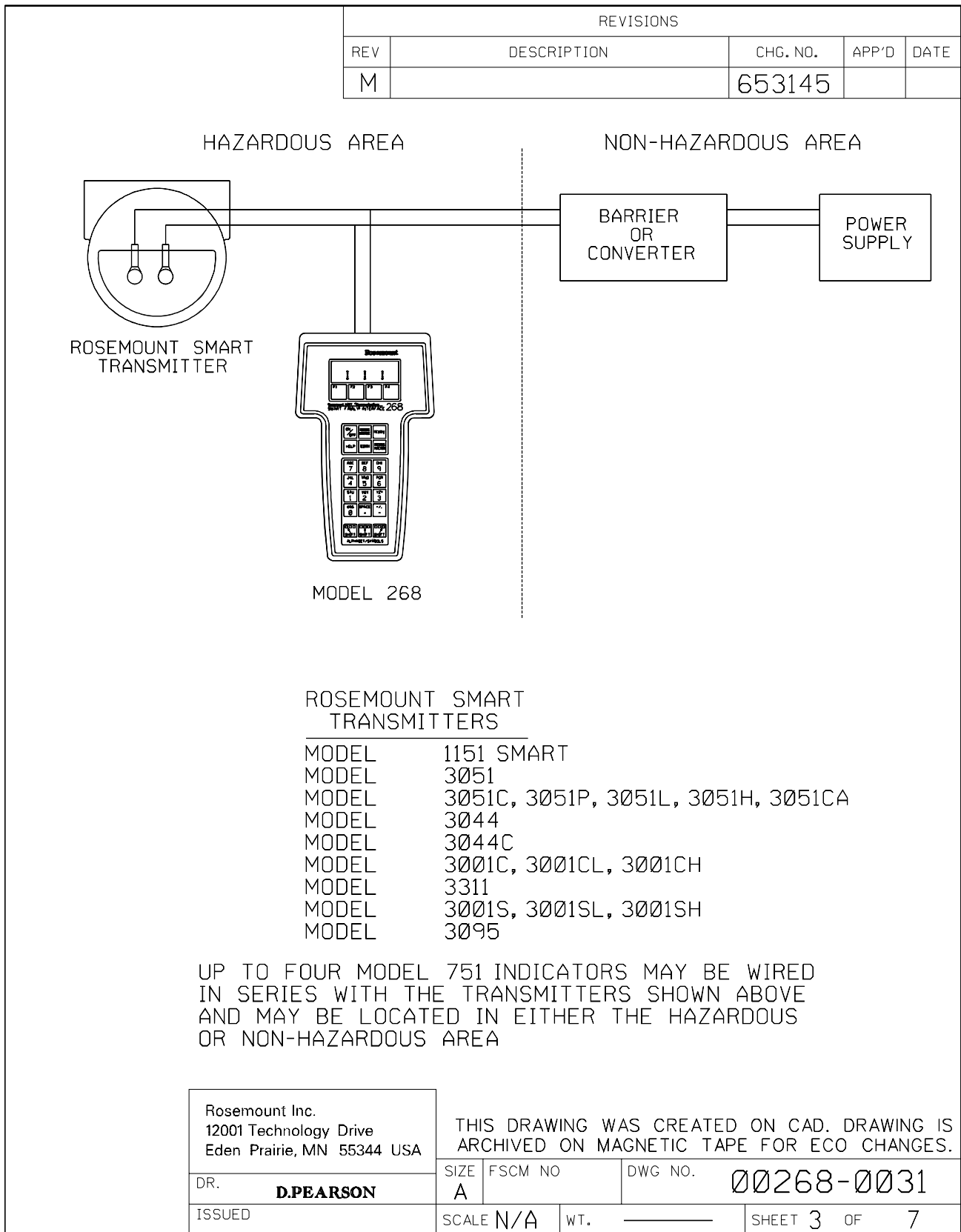
THIS DRAWING WAS CREATED ON CAD. DRAWING IS ARCHIVED ON MAGNETIC TAPE FOR ECO CHANGES.

|   |                                   |  |   |       |         |              |
|---|-----------------------------------|--|---|-------|---------|--------------|
| UNLESS OTHERWISE SPECIFIED DIMENSIONS IN INCHES. REMOVE ALL BURRS AND SHARP EDGES. MACHINE SURFACE FINISH 125<br>- TOLERANCES -<br><br>DECIMALS    FRACTIONS<br>.X±.1        ±1/32<br>.XX±.02     ANGLES<br>.XXX±.010   ±2°<br><br>DO NOT SCALE PRINT | CONTRACT NO.                      | <b>ROSEMOUNT</b> ® Measurement Control Analytical Valves<br>Rosemount Inc.<br>12001 Technology Drive<br>Eden Prairie, MN 55344 USA | TITLE   | SIZE  | FSCM NO | DWG NO.      |
|   | DR. <b>MIKE DOBE</b> 2/7/90       |  | INDEX OF I.S. BARRIER SYSTEMS FOR MOD. 268 SMART FAMILY INTERFACE | A     |         | 00268-0031   |
|   | CHK'D                             |  |   | SCALE | WT.     | SHEET 1 OF 7 |
|   | APP'D. <b>K. CARLSON</b> 03/13/90 |  | APP'D. GOVT.  |       |         |              |
|   |                                   |  |   |       |         |              |

FORM NO. 60651A-1 REV. C

| REVISIONS  |             |   |           |   |
|--|-------------|---|-----------|---|
| REV  | DESCRIPTION | CHG. NO.  | APP'D     | DATE  |
| M  |             | 653145  |           |   |
| <p><b>ENTITY CONCEPT APPROVALS</b></p> <p>THE ENTITY CONCEPT ALLOWS INTERCONNECTION OF INTRINSICALLY SAFE APPARATUS TO ASSOCIATED APPARATUS NOT SPECIFICALLY EXAMINED IN COMBINATION AS A SYSTEM. THE APPROVED VALUES OF MAXIMUM OPEN CIRCUIT VOLTAGE (<math>V_T</math> OR <math>V_{OC}</math>) AND MAXIMUM SHORT CIRCUIT CURRENT (<math>I_T</math> OR <math>I_{SC}</math>) AND MAXIMUM OUTPUT POWER (<math>\frac{V_{OC} \times I_{SC}}{4}</math> OR <math>\frac{V_T \times I_T}{4}</math>), FOR THE ASSOCIATED APPARATUS MUST BE LESS THAN OR EQUAL TO THE MAXIMUM SAFE INPUT VOLTAGE (<math>V_{MAX}</math>), MAXIMUM SAFE INPUT CURRENT (<math>I_{MAX}</math>) AND MAXIMUM SAFE INPUT POWER (<math>P_{MAX}</math>) OF THE INTRINSICALLY SAFE APPARATUS. IN ADDITION, THE APPROVED MAXIMUM ALLOWABLE CONNECTED CAPACITANCE (<math>C_A</math>) AND INDUCTANCE (<math>L_A</math>) OF THE ASSOCIATED APPARATUS MUST BE GREATER THAN THE MAXIMUM UNPROTECTED INTERNAL CAPACITANCE (<math>C_I</math>) AND INDUCTANCE (<math>L_I</math>) OF THE INTRINSICALLY SAFE APPARATUS. THE APPROVED ENTITY CONCEPT PARAMETERS ARE AS FOLLOWS:<br/>ARE AS FOLLOWS:</p> <p style="text-align: center;">NOTE: ENTITY PARAMETERS LISTED APPLY ONLY TO ASSOCIATED APPARATUS WITH LINEAR OUTPUT.</p> |             |   |           |   |
| INPUT PARAMETERS (CLASS I, DIV. 1, GROUPS A, B, C, D)  |             |   |           |   |
| Vmax = 32 Vdc  |             | VT or Voc of barrier must be $\leq$ 32 Vdc  |           |   |
| Imax = 186 mA  |             | IT or Isc of barrier must be $\leq$ 186 mA  |           |   |
| CI = 0.01 $\mu$ F  |             | CA of barrier must be $\geq$ 0.01 $\mu$ F   |           |   |
| LI = 1.1 mH  |             | LA of barrier must be $\geq$ 1.1 mH   |           |   |
| Pmax:  | 1.1W        | 0.8W  | 0.6W      | $\frac{V_{OC} \times I_{SC}}{4}$ of barrier must be $\leq$ specified value. |
| Temp code  | T4A         | T5  | T6        |   |
| OUTPUT PARAMETERS  |             |   |           |   |
| Voc = 1.5 Vd.c.  |             |   |           |   |
| Isc = 27 mA  |             |   |           |   |
| CA = 10,000 $\mu$ F  |             |   |           |   |
| LA = 46 mH   |             |   |           |   |
| Rosemount Inc.<br>12001 Technology Drive<br>Eden Prairie, MN 55344 USA   |             | THIS DRAWING WAS CREATED ON CAD. DRAWING IS<br>ARCHIVED ON MAGNETIC TAPE FOR ECO CHANGES. |           |   |
| DR. <b>D.PEARSON</b>   |             | SIZE<br><b>A</b>  | FSCM NO   | DWG NO. <b>00268-0031</b>   |
| ISSUED   |             | SCALE <b>N/A</b>  | WT. _____ | SHEET <b>2</b> OF <b>7</b>  |

FORM NO. 60651A-1 REV. C



| REVISIONS |             |          |       |      |
|-----------|-------------|----------|-------|------|
| REV       | DESCRIPTION | CHG. NO. | APP'D | DATE |
| M         |             | 653145   |       |      |

THE MAXIMUM ALLOWABLE CONNECTED INDUCTANCE ( $L_a$ ) OF THE ASSOCIATED APPARATUS IS DETERMINED BY ADDING 27 mA TO THE  $I_{sc}$  OF THE BARRIER ( $I_m = I_{sc} + 27\text{mA}$ ) AND ENTERING TABLE 1 (SHT 5) AT THE RESULTING VALUE,  $I_m$ , OR THE NEXT HIGHER VALUE OF  $I_m$ , TO DETERMINE THE  $L_a$ , (THE  $L_a$  MUST INCLUDE THE  $L_1$  OF THE MODEL 268, WHICH IS 1.1mH).

EXAMPLE #1:  $I_{sc}$  OF BARRIER = 100mA.

$$I_m = 100\text{mA} + 27\text{mA} = 127\text{mA}$$

ENTER TABLE AT  $I_m = 130\text{mA}$ ;  $L_a = 2.0\text{mH}$

--WARNING-- BEFORE CONNECTING THE MODEL 268 INTO THE LOOP, DETERMINE THE CONNECTED INDUCTANCE OF THE SYSTEM BY ADDING THE  $L_1$  OF THE TRANSMITTER, CABLE, AND MODEL 268. THE SUM MUST BE LESS THAN THE  $L_a$  DETERMINED FROM THE TABLE IN ORDER FOR THE MODEL 268 TO BE CONNECTED INTO THE LOOP. IF THE CONNECTED INDUCTANCE IS GREATER THAN THE VALUE DETERMINED FROM THE TABLE, A BARRIER WITH A LOWER  $I_{sc}$  MUST BE CHOSEN.

EXAMPLE #2: BARRIER  $I_{sc}$  = 41.8mA; BARRIER  $L_a$  = 20.0mH

$$I_m = 41.8\text{mA} + 27\text{mA} = 68.8\text{mA}$$

ENTER TABLE AT 70mA AND READ  $L_a = 7.5\text{mH}$

ADD CONNECTED INDUCTANCE OF SYSTEM:

|                            |                       |
|----------------------------|-----------------------|
| MODEL 268                  | $L_1 = 1.1\text{mH}$  |
| MODEL 3051 TRANSMITTER     | $L_1 = 0.48\text{mH}$ |
| INDUCTANCE OF LOOP WIRING  | 1.0mH                 |
| -----                      |                       |
| TOTAL CONNECTED INDUCTANCE | = 2.58mH              |

TOTAL CONNECTED INDUCTANCE IS LESS THAN  $L_a = 7.5$  mH AS DETERMINED ABOVE AND IS ALSO LESS THAN THE BARRIER  $L_a$ . THE MODEL 268 MAY SAFELY BE CONNECTED INTO THE LOOP. IF THE MODEL 751 INDICATORS ARE USED, THEIR TOTAL INDUCTANCE (LABEL VALUE \* NUMBER OF INDICATORS) MUST ALSO BE INCLUDED.

S.BARDUSON

30 JUL 90

|       |         |         |              |
|-------|---------|---------|--------------|
| SIZE  | FSCM NO | DWG NO. | 00268-0031   |
| A     |         |         |              |
| SCALE | N/A     | WT.     | SHEET 4 OF 7 |

| REVISIONS |             |          |       |      |
|-----------|-------------|----------|-------|------|
| REV       | DESCRIPTION | CHG. NO. | APP'D | DATE |
| M         |             | 653145   |       |      |

| Im (mA) | La (mH) |
|---------|---------|
| 150     | 1.3     |
| 145     | 1.5     |
| 140     | 1.6     |
| 130     | 2.0     |
| 120     | 2.5     |
| 110     | 3.0     |
|         |         |
| 100     | 4.0     |
| 90      | 5.0     |
| 85      | 5.5     |
| 80      | 6.0     |
| 75      | 6.7     |
|         |         |
| 70      | 7.5     |
| 65      | 8.8     |
| 62      | 9.5     |
| 60      | 10.0    |
| 57      | 11.0    |
|         |         |
| 55      | 12.0    |
| 50      | 15.0    |
| 45      | 19.0    |
| 40      | 23.0    |
| 35      | 31.0    |

TABLE 1

Rosemount Inc.  
 12001 Technology Drive  
 Eden Prairie, MN 55344 USA

DR. **S.BARDUSON** 30JUL90

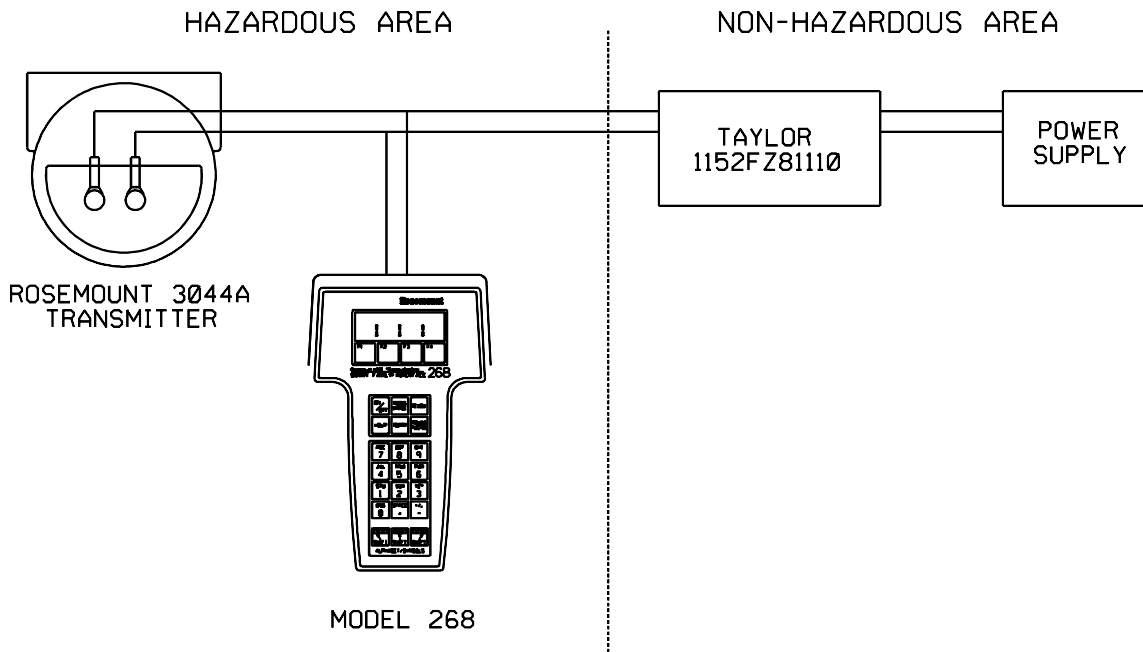
ISSUED

THIS DRAWING WAS CREATED ON CAD. DRAWING IS ARCHIVED ON MAGNETIC TAPE FOR ECO CHANGES.

|       |         |              |
|-------|---------|--------------|
| SIZE  | FSCM NO | DWG NO.      |
| A     |         | 00268-0031   |
| SCALE | N/A     | WT. _____    |
|       |         | SHEET 5 OF 7 |

| REVISIONS |             |          |       |      |
|-----------|-------------|----------|-------|------|
| REV       | DESCRIPTION | CHG. NO. | APP'D | DATE |
|           |             |          |       |      |

TAYLOR 1152FZ81110 SYSTEM



ROSEMOUNT 3044A SMART TRANSMITTERS MAY BE PLACED IN A CLASS I, DIVISION I, GROUP A, B, C, D HAZARDOUS LOCATION AS SHOWN ABOVE. THE LOOP POWER IS LIMITED BY A TAYLOR 1152FZ81110 INTRINSIC SAFETY BARRIER. THE ROSEMOUNT 268 MAY ALSO BE CONNECTED IN THE LOOP AS SHOWN. FOR CABLE WITH CAPACITANCE OF 60 pF/ft OR LESS AND INDUCTANCE OF .2 uH/ft OR LESS; CABLE LENGTHS OF UP TO 1600 FEET ARE ALLOWED.

TRANSMITTER: ROSEMOUNT 3044A  
 BARRIER: TAYLOR 1152FZ81110  
 COMMUNICATOR: ROSEMOUNT 268  
 CABLE: C<sub>max</sub> = 60 pF/ft  
 L<sub>max</sub> = .2 uH/ft  
 MAX. LENGTH = 1600 ft

|  |                             |
|--|-----------------------------|
| Rosemount Inc.<br>12001 Technology Drive<br>Eden Prairie, MN 55344 USA |                             |
| DR.  | <b>C. SCRIBNER</b> 12/21/90 |
| ISSUED   |                             |

|  |         |         |            |
|--|---------|---------|------------|
| THIS DRAWING WAS CREATED ON CAD. DRAWING IS ARCHIVED ON MAGNETIC TAPE FOR ECO CHANGES. |         |         |            |
| SIZE   | FSCM NO | DWG NO. | 00268-0031 |
| A  |         |         |            |
| SCALE  | N/A     | WT.     |            |
|  |         | SHEET   | 6 OF 7     |

FORM NO. 60651A-1 REV. C







| REVISIONS |             |          |       |      |
|-----------|-------------|----------|-------|------|
| REV       | DESCRIPTION | CHG. NO. | APP'D | DATE |
| B         |             | 657178   |       |      |

FM ENTITY CONCEPT APPROVALS

THE ENTITY CONCEPT ALLOWS INTERCONNECTION OF INTRINSICALLY SAFE APPARATUS TO ASSOCIATED APPRATUS NOT SPECIFICALLY EXAMINED IN COMBINATION AS A SYSTEM. THE APPROVED VALUES OF MAXIMUM OPEN CIRCUIT VOLTAGE ( $V_T$  OR  $V_{OC}$ ) AND MAXIMUM SHORT CIRCUIT CURRENT ( $I_T$  OR  $I_{SC}$ ) FOR THE ASSOCIATED APPARATUS MUST BE LESS THAN OR EQUAL TO THE MAXIMUM SAFE INPUT VOLTAGE ( $V_{MAX}$ ) AND MAXIMUM SAFE INPUT CURRENT ( $I_{MAX}$ ) OF THE INTRINSICALLY SAFE APPARATUS, IN ADDITION, THE APPROVED MAXIMUM ALLOWABLE CONNECTED CAPACITANCE ( $C_A$ ) AND INDUCTANCE ( $L_A$ ) OF THE ASSOCIATED APPARATUS MUST BE GREATER THAN THE MAXIMUM UNPROTECTED INTERNAL CAPACITANCE ( $C_I$ ) AND INDUCTANCE ( $L_I$ ) OF THE INTRINSICALLY SAFE APPARATUS. THE APPROVED ENTITY CONCEPT PARAMETERS ARE AS FOLLOWS:

NOTE: ENTITY PARAMETERS LISTED APPLY ONLY TO ASSOCIATED APPARATUS WITH LINEAR OUTPUT.

INPUT PARAMETERS (CLASS I, DIV. 1, GROUPS A, B, C, D)

|                            |  |
|----------------------------|--|
| $V_{max} = 30 \text{ Vdc}$ | $V_T$ or $V_{oc}$ of barrier must be $\leq 30 \text{ Vdc}$ |
| $I_{max} = 300 \text{ mA}$ | $I_T$ or $I_{sc}$ of barrier must be $\leq 300 \text{ mA}$ |
| $C_1 = 0.07 \mu\text{F}$   | $C_A$ of barrier must be $\geq 0.07 \mu\text{F}$           |
| $L_1 = 0 \text{ mH}$       | $L_A$ of barrier must be $\geq 0 \text{ mH}$               |

OUTPUT PARAMETERS

|                              |
|------------------------------|
| $V_{oc} = 1.7 \text{ Vd.c.}$ |
| $I_{sc} = 32 \text{ mA}$     |

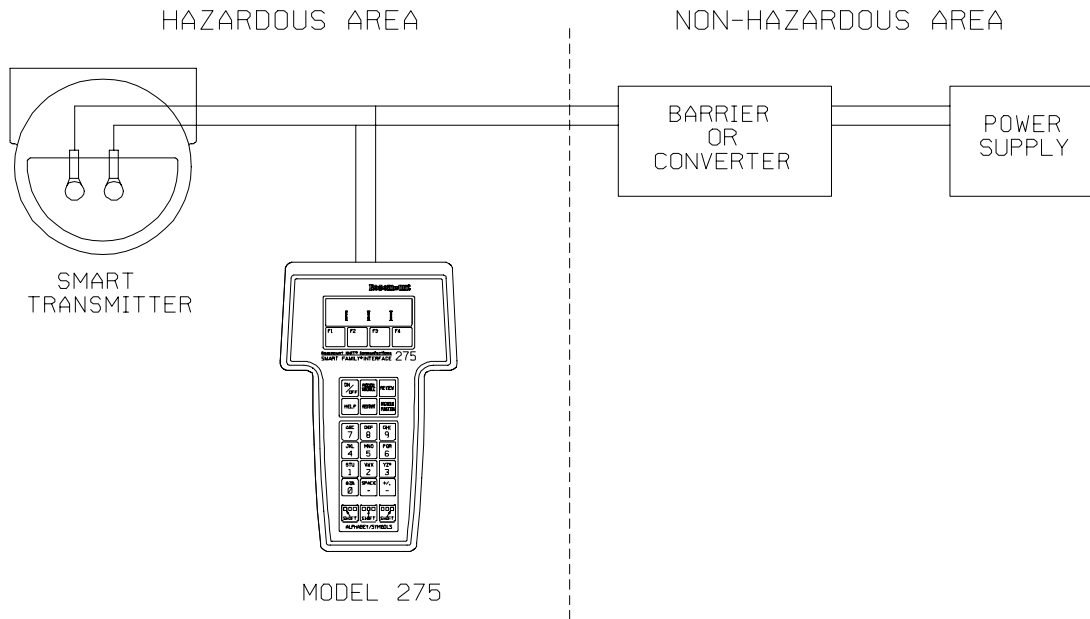
|  |
|--|
| Rosemount inc.<br>12001 Technology Drive<br>Eden Prairie, MN 55344 USA |
| DR. <b>C. SCRIBNER</b>   |
| ISSUED   |

THIS DRAWING WAS CREATED ON CAD. DRAWING IS ARCHIVED ON MAGNETIC TAPE FOR ECO CHANGES.

|                  |           |                              |
|------------------|-----------|------------------------------|
| SIZE<br><b>A</b> | FSCM NO   | DWG NO.<br><b>00275-0081</b> |
| SCALE <b>N/A</b> | WT. _____ | SHEET <b>2</b> OF <b>6</b>   |

**Rosemount Model 1151 Smart Pressure Transmitters**

| REVISIONS |             |          |       |      |
|-----------|-------------|----------|-------|------|
| REV       | DESCRIPTION | CHG. NO. | APP'D | DATE |
| B         |             | 657178   |       |      |



Rosemount Inc.  
 12001 Technology Drive  
 Eden Prairie, MN 55344 USA

DR. **C. SCRIBNER**

ISSUED

THIS DRAWING WAS CREATED ON CAD. DRAWING IS ARCHIVED ON MAGNETIC TAPE FOR ECO CHANGES.

|          |         |         |                   |
|----------|---------|---------|-------------------|
| SIZE     | FSCM NO | DWG NO. | <b>00275-0081</b> |
| <b>A</b> |         |         |                   |
| SCALE    | N/A     | WT.     | —                 |
|          |         | SHEET   | 3 OF 6            |

| REVISIONS |             |          |       |      |
|-----------|-------------|----------|-------|------|
| REV       | DESCRIPTION | CHG. NO. | APP'D | DATE |
| B         |             | 657178   |       |      |

THE MAXIMUM ALLOWABLE CONNECTED INDUCTANCE ( $L_a$ ) OF THE ASSOCIATED APPARATUS IS DETERMINED BY ADDING 32 mA TO THE  $I_{sc}$  OF THE BARRIER ( $I_m = I_{sc} + 32mA$ ) AND ENTERING TABLE 1 (SHT 5) AT THE RESULTING VALUE,  $I_m$ , OR THE NEXT HIGHER VALUE OF  $I_m$ , TO DETERMINE THE  $L_a$ .

EXAMPLE #1:  $I_{sc}$  OF BARRIER = 100mA. (GROUP A)

$$I_m = 100mA + 32mA = 132mA$$

ENTER TABLE AT  $I_m = 140mA$ ;  $L_a = 1.60mH$

--WARNING-- BEFORE CONNECTING THE MODEL 275 INTO THE LOOP, DETERMINE THE CONNECTED INDUCTANCE OF THE SYSTEM BY ADDING THE  $L_1$  OF THE TRANSMITTER AND CABLE. THE SUM MUST BE LESS THAN THE  $L_a$  DETERMINED FROM THE TABLE IN ORDER FOR THE MODEL 275 TO BE CONNECTED INTO THE LOOP. IF THE CONNECTED INDUCTANCE IS GREATER THAN THE VALUE DETERMINED FROM THE TABLE, A BARRIER WITH A LOWER  $I_{sc}$  MUST BE CHOSEN.

EXAMPLE #2: BARRIER  $I_{sc}$  = 41.8mA; BARRIER  $L_a$  = 20.0mH

$$I_m = 41.8mA + 32mA = 73.8mA;$$

ENTER TABLE AT 80mA AND READ  $L_a = 6.0mH$

ADD CONNECTED INDUCTANCE OF SYSTEM:

|                            |                |
|----------------------------|----------------|
| MODEL 3051 TRANSMITTER     | $L_1 = 0.48mH$ |
| INDUCTANCE OF LOOP WIRING  | 1.0mH          |
| -----                      |                |
| TOTAL CONNECTED INDUCTANCE | = 1.48mH       |

TOTAL CONNECTED INDUCTANCE IS LESS THAN  $L_a = 6.0$  mH AS DETERMINED ABOVE AND IS ALSO LESS THAN THE BARRIER  $L_a$ . THE MODEL 275 MAY SAFELY BE CONNECTED INTO THE LOOP. IF THE MODEL 751 INDICATORS ARE USED, THEIR TOTAL INDUCTANCE (LABEL VALUE \* NUMBER OF INDICATORS) MUST ALSO BE INCLUDED.

|   |        |   |         |
|---|--------|---|---------|
| <b>Rosemount Inc.</b><br>12001 Technology Drive<br>Eden Prairie, MN 55344 USA |        | THIS DRAWING WAS CREATED ON CAD. DRAWING IS<br>ARCHIVED ON MAGNETIC TAPE FOR ECO CHANGES. |         |
| DR. <b>C. SCRIBNER</b>  | 6/2/93 | SIZE <b>A</b>   | FSCM NO |
| ISSUED  |        | DWG NO. <b>00275-0081</b>   | WT.     |
| SCALE <b>N/A</b>  |        | SHEET <b>4</b> OF <b>6</b>  |         |

| REVISIONS |             |          |       |      |
|-----------|-------------|----------|-------|------|
| REV       | DESCRIPTION | CHG. NO. | APP'D | DATE |
| B         |             | 657178   |       |      |

| I <sub>m</sub><br>(mA) | L <sub>a</sub> (mH) |         |         |
|------------------------|---------------------|---------|---------|
|                        | GROUPS A & B        | GROUP C | GROUP D |
| 300                    | 0.20                | 1.80    | 3.20    |
| 280                    | 0.21                | 2.00    | 3.70    |
| 270                    | 0.23                | 2.20    | 3.90    |
| 260                    | 0.25                | 2.50    | 4.30    |
| 250                    | 0.27                | 2.70    | 4.60    |
| 240                    | 0.30                | 3.00    | 5.00    |
| 220                    | 0.40                | 3.20    | 5.90    |
| 200                    | 0.50                | 4.00    | 7.20    |
| 180                    | 0.60                | 5.00    | 8.80    |
| 170                    | 0.80                | 5.50    | 9.90    |
| 160                    | 1.00                | 6.20    | 11.20   |
| 150                    | 1.30                | 7.00    | 12.70   |
| 140                    | 1.60                | 8.00    | 14.60   |
| 130                    | 2.00                | 9.00    | 16.90   |
| 120                    | 2.50                | 10.00   | 19.80   |
| 110                    | 3.00                | 12.00   | 23.60   |
| 100                    | 4.00                | 15.00   | 28.50   |
| 90                     | 5.00                | 18.00   | 35.10   |
| 85                     | 5.50                | 20.00   | 39.30   |
| 80                     | 6.00                | 22.00   | 44.40   |
| 75                     | 6.70                | 25.00   | 50.50   |
| 70                     | 7.50                | 28.00   | 57.90   |
| 65                     | 8.80                | 34.00   | 67.10   |
| 62                     | 9.50                | 37.00   | 73.70   |
| 60                     | 10.00               | 40.00   | 78.70   |
| 57                     | 11.00               | 43.00   | 87.10   |
| 55                     | 12.00               | 48.00   | 93.50   |
| 50                     | 15.00               | 56.00   | 113.10  |
| 45                     | 19.00               | 70.00   | 139.40  |
| 40                     | 23.00               | 87.00   | 176.30  |
| 35                     | 31.00               | 110.00  | 229.90  |
| 32                     | 36.00               | 135.00  | 274.80  |
| 30                     | 40.00               | 150.00  | 312.40  |
| 28                     | 46.00               | 170.00  | 358.40  |
| 25                     | 58.00               | 210.00  | 449.00  |
| 23                     | 68.00               | 250.00  | 530.10  |
| 21                     | 82.00               | 300.00  | 635.30  |
| 20                     | 90.00               | 330.00  | 700.00  |

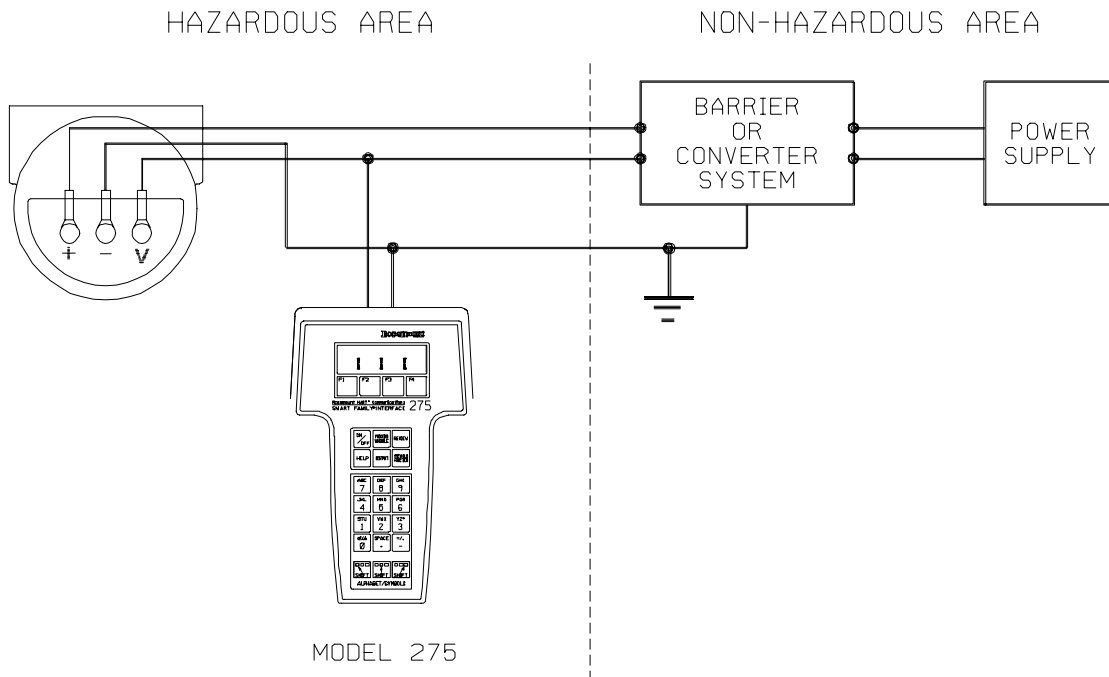
TABLE 1

Rosemount Inc.  
12001 Technology Drive  
Eden Prairie, MN 55344 USA

THIS DRAWING WAS CREATED ON CAD. DRAWING IS  
ARCHIVED ON MAGNETIC TAPE FOR ECO CHANGES.

|                        |        |                  |           |                              |
|------------------------|--------|------------------|-----------|------------------------------|
| DR. <b>C. SCRIBNER</b> | 6/2/93 | SIZE<br><b>A</b> | FSCM NO.  | DWG NO.<br><b>00275-0081</b> |
| ISSUED                 |        | SCALE <b>N/A</b> | WT. _____ | SHEET <b>5</b> OF <b>6</b>   |

| REV | DESCRIPTION | CHG. NO. | APP'D | DATE |
|-----|-------------|----------|-------|------|
| B   |             | 657178   |       |      |



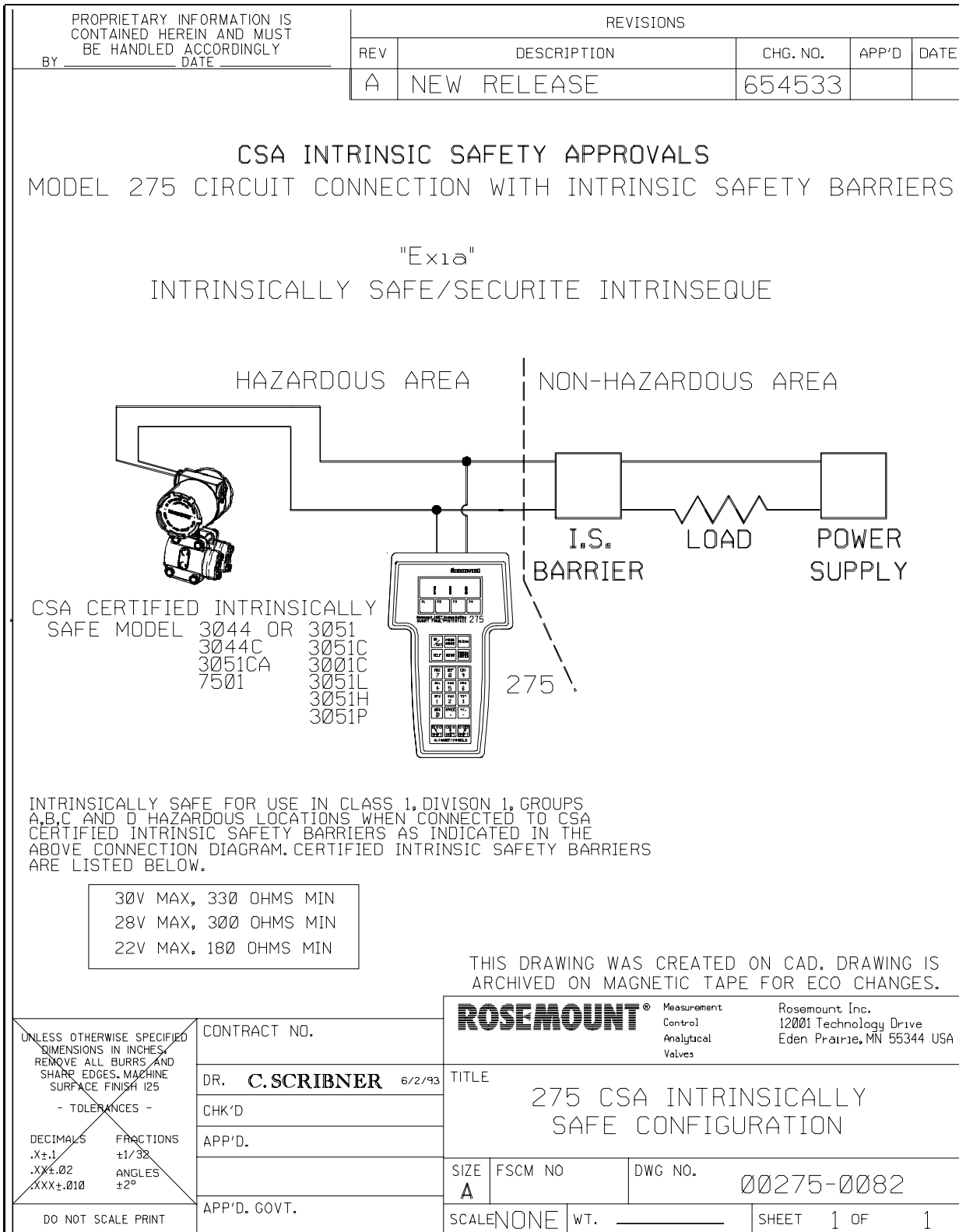
Rosemount Inc.  
 12001 Technology Drive  
 Eden Prairie, MN 55344 USA

DR. **C. SCRIBNER** 6/2/93

ISSUED

THIS DRAWING WAS CREATED ON CAD. DRAWING IS ARCHIVED ON MAGNETIC TAPE FOR ECO CHANGES.

|                  |           |                              |
|------------------|-----------|------------------------------|
| SIZE<br><b>A</b> | FSCM NO   | DWG NO.<br><b>00275-0081</b> |
| SCALE <b>N/A</b> | WT. _____ | SHEET <b>6 OF 6</b>          |





Some of the terms used in this manual relate specifically to the operation of Rosemount transmitters, hand-held communicators, and other Rosemount products. The following list provides brief definitions. See the sections listed for additional information.

|  |   |
|--|---|
| <b>Analog Output Trim</b>                                    | Digital trim operation that allows adjustment of the output electronics to conform to the plant standard of current. Three types of analog output trim are available: 4–20 mA output trim, 4–20 mA other scale, and low power.  |
| <b>Cloning</b>   | Off-line operation that uses a HART-based communicator to copy configuration data from one transmitter to one or more other transmitters that require the same data.  |
| <b>Commissioning</b>   | Functions performed with the HART-based communicator and the transmitter that test the transmitter and test the loop, and verify transmitter configuration data.  |
| <b>Configuration</b>   | Process of setting parameters that determine how the transmitter operates.  |
| <b>Damping</b>   | Output function that increases the response time of the transmitter to smooth the output when there are rapid input variations.   |
| <b>Descriptor</b>  | Sixteen-character field for additional identification of the transmitter, its use, or location. The descriptor is stored in the transmitter and can be changed using the HART-based communicator.   |
| <b>Digital Trim</b>  | Format function that allows you to adjust the transmitter characterization for purposes of digital calibration to plant standards. Digital trim includes two separate operations: sensor trim and analog output trim.   |
| <b>Failure Mode Alarm</b>                                    | Transmitter function that drives the analog output to a jumper-selectable high or low value in the event of an electronics failure.   |
| <b>Factory Characterization</b>                              | Factory process during which each sensor module is subjected to pressures and temperatures covering the full operating range. The sensor module memory stores data generated from this process for use by the microprocessor in correcting the transmitter output during operation. |
| <b>Full Trim</b>   | Sensor trim function in which two accurate, end-point pressures are applied and all output is linearized between them. The selected end points should always be equal to or outside the LRV and URV.  |
| <b>HART (Highway Addressable Remote Transducer) Protocol</b> | Communications standard that provides simultaneous analog and digital signal transmission between control rooms and field devices such as transmitters. All Rosemount SMART FAMILY products communicate using the HART protocol.  |
| <b>Lower Range Limit (LRL)</b>                               | Lowest value of the measured variable that the transmitter can be configured to measure.  |

|                                |  |
|--------------------------------|--|
| <b>Lower Range Value (LRV)</b> | Lowest value of the measured variable that the analog output of the transmitter is currently configured to measure.  |
| <b>Multidropping</b>           | The connection of several transmitters to a single communications transmission line. Communication between the host and the transmitters takes place digitally with the analog output of the transmitters deactivated. |
| <b>Reranging</b>               | Configuration function that changes the transmitter 4 and 20 mA settings.  |
| <b>Send Data</b>               | HART-based communicator command that transfers configuration data from the hand-held communicator's memory to the transmitter memory.  |
| <b>Sensor Trim</b>             | Digital trim function that allows you to adjust the digital process variable reading to a precise pressure input. Zero trim and full trim are the two sensor trim functions.   |
| <b>Smart</b>                   | Term used to describe instruments that are microprocessor-based and feature advanced communications capabilities.  |
| <b>SMART FAMILY</b>            | Rosemount pressure, temperature, level, and flow instruments with microprocessor-based digital electronics.  |
| <b>Span</b>                    | Algebraic difference between the upper and lower range values.   |
| <b>Tag</b>                     | Eight-character field for identifying the transmitter. The tag is stored in the transmitter and can be changed using the Model 268 Communicator and the transmitter information function.                              |
| <b>Transmitter Address</b>     | Unique number (1-15) used to identify a multidropped transmitter. Transmitters that are not multidropped have 0 as an address.   |
| <b>Transmitter Security</b>    | Jumper-selectable feature that prevents accidental or deliberate changes to configuration data.  |
| <b>Upper Range Limit (URL)</b> | Highest value of the measured variable that the transmitter can be configured to measure.  |
| <b>Upper Range Value (URV)</b> | Highest value of the measured variable that the analog output of the transmitter is currently configured to measure.   |
| <b>Zero Trim</b>               | A zero-based, one-point adjustment used in differential pressure applications to compensate for mounting position effects or zero shifts caused by static pressure.  |

## A

Access Requirements  
  Circuit Side of Electronics  
  Housing 3-4  
  Exterior of Electronics  
  Housing 3-4  
  Process Flange Orientation 3-3  
  Terminal Side of Electronics  
  Housing 3-4

### Action Keys

  Hot Key A-6  
  ON/OFF Key A-6  
  Up Arrow Key A-6

Alphanumeric and Shift Keys B-6

Amplifier Board Standoffs C-5

Analog Electronics (Figure 12-1) C-3

Analog Electronics Assembly C-2

Approvals 5-2, 5-4

## B

Board Spacers C-10

### Brackets

  Mounting Options 3-10

## C

Calibrate the Sensor 2-12

Certifications 5-2, 5-4

### Characterization

  Before Characterizing the  
  Transmitter C-13

  Characterizing with a Model 275  
  Communicator C-13

Checking the Transmitter

  Output 2-4

Circuit Side of Electronics

  Housing 3-4

Commissioning the Model 3051 with  
  a HART-Based Communicator 2-3

Commissioning the Transmitter on  
  the Bench 2-1

### Configuration

  LCD Meter 3-16

  Standard 5-8

### Connections

  Electrical Housing to the  
  Sensor 4-8

  Header Board (Figure 9-4) 4-11

## D

Dedicated Keys B-5

Digital Trim (Analog Output Trim  
  and Sensor Trim) 2-12

Drain/Vent Valves 3-8

## E

Electrical Housing 4-7, 4-8

### Electrical Installation

  Considerations 3-11

  Grounding 3-12

  Power Supply 3-11

  Signal and Test Terminals 3-12

  Wiring 3-12

Entity Approvals 5-2, 5-4

Environmental Considerations 3-15

### Environmental Requirements

  Mounting Requirements 3-7

Exterior of Electronics Housing 3-4

## F

### Filter Terminal Blocks

  Installation 3-19

Full Trim 2-12

### Function Keys

  Help Key A-7

  Home Key A-7

Functional Specifications 5-1

## G

### Gas

  Mounting Requirements 3-7

Grounding 3-12

  Effects on Accuracy for Fast  
  Sample Computers 3-14

  Transmitter Case 3-13

## H

### HART Communicator

  Data Entry A-7, B-6

Hazardous Locations 3-15

Header Board Connections  
  (Figure 9-4) 4-11

### Housing

  Electrical 4-7, 4-8

    Connecting Sensor 4-8

    Sensor Removal 4-7

  Electronic

    Circuit Side 3-4

    Exterior 3-4

    Terminal Side 3-4

  Rotation 3-4

## I

Impulse Piping 3-8

  Installation Diagrams 3-7

Installation 3-19

Board Spacers C-10

Electrical Considerations 3-11

### Environmental

  Considerations 3-15

General Considerations 3-3

Hazardous Locations 3-15

Mechanical Considerations 3-3

Mounting Bracket Options 3-10

Mounting Considerations 3-10

Power Supply Load

  Limitations 3-11

Process Considerations 3-9

Signal Wiring Grounding 3-13

Smart Retrofit Kit C-10

### Installation Diagrams

  Impulse Piping 3-7

Integral Span and Zero Buttons 2-10

## K

### Keypad

  Action Keys A-6

  Hot Key A-6

## L

LCD Meter 3-16

  Assembly 3-17

  Configuration 3-16

  Specifications 5-30

### Liquid

  Mounting Requirements 3-7

## M

### Maintenance

  Reassembly Procedure 4-8

  Return of Material 4-11

  Sensor Module Checkout 4-10

  Troubleshooting Symptoms and  
  Corrective Action (Table  
  9-2) 4-3

### Mechanical Installation

  Considerations 3-3

Model 1151 Analog Electronics  
  (Figure 12-1) C-3

Mounting Bracket Options  
  (Figure 4-2) 3-10

Mounting Considerations 3-10

Mounting Requirements 3-7

  Drain/Vent Valves 3-8

  Impulse Piping 3-8

  Taps 3-7

### O

- ON/OFF Key A-6
- On-line Configuration
  - Transmitter Security 2-2
- Optional Plug-in Meter 4-10
- Options
  - LCD Meter 3-16

### P

- Performance Specifications 5-7
- Physical Specifications Standard Configuration 5-8
- Piping
  - Impulse Piping 3-8
- Power Supply 3-11
  - Load Limitations 3-11
- Process Considerations 3-9
- Process Flange Orientation 3-3
- Process Sensor Body 4-6, 4-8
- Process Variable 2-4

### R

- Rangeability 5-1
- Reassembly Procedure 4-8
  - Connecting the Electrical Housing to the Sensor 4-8
  - Electrical Housing 4-8
  - Optional Plug-in Meter 4-10
  - Process Sensor Body 4-8
- Removing Power C-3
  - Removing the Amplifier Board Standoffs C-5
- Removing the Analog Electronics Assembly C-2
- Removing the Sensor from the Electrical Housing 4-7
- Reranging the Transmitter
  - Using the Integral Span and Zero Buttons 2-10
- Retrofit Kit C-10
- Retrofitting the Model 1151 Transmitter
  - Installing the Board Spacers C-10
  - Installing the Smart Retrofit Kit C-10
  - Model 1151 Analog Electronics (Figure 12-1) C-3
  - Removing Power C-3
  - Removing the Analog Electronics Assembly C-2
- Return of Material 4-11
- Reviewing Transmitter Configuration Data 2-4
- Rotating Housing 3-4

### S

- Sending Data to the Transmitter 2-7
  - Sensor
    - Connecting to the Electrical Housing 4-8
    - Removal from Electrical Housing 4-7
  - Sensor Module Checkout 4-10
    - Header Board Connections (Figure 9-4) 4-11
  - Sensor Trim 2-12
  - Setting Output Units 2-5
  - Setting the Loop to Manual 2-7
  - Signal Terminals 3-12
  - Signal Wiring Grounding 3-13
  - Smart Retrofit Kit C-10
  - Software Defined Function Keys B-6
  - Specifications and Reference Data 5-1
    - Functional Specifications 5-1
    - Model 1151 Transmitter Range Availability 5-1
    - Performance Specifications 5-7
    - Physical Specifications Standard Configuration 5-8
    - Rangeability (Table 10-1) 5-1
  - Startup
    - Testing Equipment and Loop 2-4
  - Steam
    - Mounting Requirements 3-7
- ### T
- Taps 3-7
  - Terminal Block
    - Specifications 5-31
  - Terminal Side of Electronics Housing 3-4
  - Terminals 3-12
    - Signal 3-12
  - Test 3-12
  - Test Terminals 3-12
  - Transient Protection
    - Installation 3-19
  - Transmitter
    - Disassembly
      - Electrical Housing 4-7
      - Process Sensor Body 4-6
      - Removing the Sensor from the Electrical Housing 4-7
      - Transmitter Exploded View 4-6
    - Range Availability (1151) 5-1
    - Security 2-2
  - Transmitter Case 3-13
  - Troubleshooting Symptoms and Corrective Action (Table 9-2) 4-3

### V

- Vent/Drain Valves 3-8

### W

- Wiring 3-12
  - Signal Terminals 3-12
  - Test Terminals 3-12

### Z

- Zero and Integral Span Buttons 2-10
- Zero Trim 2-13



**Rosemount Inc.**

8200 Market Boulevard  
Chanhassen, MN 55317 USA  
Tel 1-800-999-9307  
Telex 4310012  
Fax (612) 949-7001  
© 1999 Rosemount Inc.



<http://www.rosemount.com>



00809-0100-4593 Rev. BA 3/99

**Fisher-Rosemount Limited**

Heath Place  
Bognor Regis  
West Sussex PO22 9SH  
England  
Tel 44 (1243) 863 121  
Fax 44 (1243) 867 5541

**Fisher-Rosemount  
Singapore Pte Ltd.**

1 Pandan Crescent  
Singapore 128461  
Tel (65) 777-8211  
Fax (65) 777-0947  
Tlx RS 61117 FRSPL

**ROSEMOUNT®**

**FISHER-ROSEMOUNT™ Managing The Process Better.™**