

Rosemount 644 Head and Rail Mount Temperature Transmitters



ROSEMOUNT[®]

www.rosemount.com

The Emerson logo, consisting of a stylized diamond shape made of horizontal lines, positioned above the text 'EMERSON' and 'Process Management'.

EMERSON[™]
Process Management

Rosemount 644 Temperature Transmitters

Rosemount 644 Hardware Revision	26
HART® Device Revision	5.6
HART Communicator Field Device Revision	Dev v6, DD v1
FOUNDATION fieldbus Hardware Revision	5
FOUNDATION fieldbus Device Revision	1

NOTICE

Read this manual before working with the product. For personal and system safety, and for optimum product performance, make sure to thoroughly understand the contents before installing, using, or maintaining this product.

The United States has two toll-free assistance numbers and one international number.

Customer Central

1-800-999-9307 (7:00 a.m. to 7:00 P.M. CST)

National Response Center

1-800-654-7768 (24 hours a day)

Equipment service needs

International

1-(952) 906-8888

⚠ CAUTION

The products described in this document are NOT designed for nuclear-qualified applications.

Using non-nuclear qualified products in applications that require nuclear-qualified hardware or products may cause inaccurate readings.

For information on Rosemount nuclear-qualified products, contact a Emerson Process Management Sales Representative.

Rosemount 644 Smart Temperature Transmitters may be protected by one or more U.S. Patents pending. Other foreign patents pending.

Table of Contents

SECTION 1 Introduction	Safety Messages	1-1	
	Warnings	1-1	
	Overview	1-2	
	Manual	1-2	
	Transmitter	1-2	
	Considerations	1-3	
	General	1-3	
	Commissioning	1-3	
	Mechanical	1-3	
	Electrical	1-3	
	Environmental	1-3	
	Return of Materials	1-4	
	SECTION 2 Installation	Safety Messages	2-1
		Warnings	2-1
Mounting		2-3	
Installation		2-4	
Typical European Installation		2-4	
Typical North American Installation		2-5	
LCD Display Installation		2-8	
Multichannel Installations (HART)		2-9	
Wiring		2-9	
Sensor Connections		2-11	
Power Supply		2-13	
Ground the Transmitter		2-14	
SECTION 3 HART Configuration		Overview	3-1
		Safety Messages	3-1
	Warnings	3-1	
	Surges/Transients	3-2	
	Commissioning	3-2	
	Setting the Loop to Manual	3-2	
	Failure Mode	3-2	
	Changing Switch Positions	3-3	
	HART Communicator	3-3	
	Configuration	3-3	
	HART Menu Tree	3-4	
	Fast Key Sequence	3-5	
	AMS	3-6	
	Apply AMS Changes	3-6	
	Review Configuration Data	3-7	
	Check Output	3-7	
Configuration	3-7		

	Information Variables	3-12
	Diagnostics and Service	3-13
	Multidrop Communication	3-18
	Operation and Maintenance	3-19
	Calibration	3-19
	Hardware	3-24
	Diagnostic Messages	3-24
SECTION 4	Overview	4-1
Foundation Fieldbus	Safety Messages	4-1
Configuration	Warnings	4-1
	General Block Information	4-2
	Device Description	4-2
	Node Address	4-2
	Modes	4-2
	Link Active Scheduler	4-3
	Block Installation	4-3
	Capabilities	4-4
	Foundation fieldbus function blocks	4-4
	Resource Block	4-5
	Sensor Transducer Block	4-9
	Analog Input (AI) Function Block	4-9
	LCD Transducer Block	4-13
	Operation and Maintenance	4-14
	Overview	4-14
	Troubleshooting Guides	4-15
	Sensor Transducer Block	4-17
	Analog Input (AI) Function Block	4-20
	Resource Block	4-22
	LCD Transducer block	4-23
APPENDIX A	HART and Foundation Fieldbus Specifications	A-1
Specifications and	Functional	A-1
Reference Data	Physical	A-2
	Performance	A-3
	Foundation Fieldbus Specifications	A-4
	4–20 mA / HART Specifications	A-6
	Dimensional Drawings	A-10
	Ordering Information	A-12
	Additional Information	A-14
	Tagging	A-14
	Considerations	A-14
	Configuration	A-15
	Stainless Steel Housing	A-16
	Dimensional Drawings	A-17
APPENDIX B	Approved Manufacturing Locations	B-1
Product Certifications	European Union Directive Information	B-1
	Hazardous Locations Certificates	B-2
	Rosemount 644 with Foundation Fieldbus	B-2
	Rosemount 644 with HART	B-5
	Installation Drawings	B-8

APPENDIX C
Foundation Fieldbus
Block Information

Basic Setup	C-1
Resource Block	C-1
Parameters and Descriptions	C-2
Sensor Transducer Block	C-5
Parameters and Descriptions	C-5
Analog Input (AI) Function Block	C-8
AI Parameter Table	C-9
LCD Transducer Block	C-12
PID Block	C-13

Section 1 Introduction

Safety Messages	page 1-1
Overview	page 1-2
Considerations	page 1-3
Return of Materials	page 1-4

SAFETY MESSAGES

Instructions and procedures in this section may require special precautions to ensure the safety of the personnel performing the operations. Information that potentially raises safety issues is indicated by a warning symbol (⚠). Please refer to the following safety messages before performing an operation preceded by this symbol.

Warnings

⚠ WARNING

Failure to follow these installation guidelines could result in death or serious injury.

- Make sure only qualified personnel perform the installation.

Explosions could result in death or serious injury.

- Do not remove the connection head cover in explosive atmospheres when the circuit is live.
- Before connecting HART or FOUNDATION fieldbus in an explosive atmosphere, make sure the instruments in the loop are installed in accordance with intrinsically safe or non-intrinsic field wiring practices.
- Verify that the operating atmosphere of the transmitter is consistent with the appropriate hazardous locations certifications.
- All connection head covers must be fully engaged to meet explosion-proof requirements.

Process leaks could result in death or serious injury.

- Do not remove the thermowell while in operation.
- Install and tighten thermowells and sensors before applying pressure

Electrical shock could cause death or serious injury.

- Use extreme caution when making contact with the leads and terminals.

OVERVIEW

Manual

This manual is designed to assist in the installation, operation, and maintenance of Rosemount 644 head mount and 644 rail mount.

Section 1: Introduction

- Transmitter and Manual Overview
- Considerations
- Return of Material

Section 2: Installation

- Mounting
- Installation
- Wiring
- Power Supply
- Commissioning

Section 3: HART Configuration

- Rosemount HART Communicator
- Configuration
- Multidrop Communication

Section 4: FOUNDATION Fieldbus Configuration

- Calibration
- Hardware Maintenance
- Diagnostic Messaging

Appendix A: Specifications and Reference Data

- Specifications
- Dimensional drawings
- Ordering Information
- Biotechnology, Pharmaceutical Industries, and Sanitary Applications

Appendix B: Approvals

- Product Certifications
- Installation Drawings

Appendix C: Foundation Fieldbus Block Information

- Information regarding the Function Blocks

Transmitter

Features of the Rosemount 644 include:

- Accepts inputs from a wide variety of sensors
- Configuration using HART protocol or FOUNDATION fieldbus
- Electronics that are completely encapsulated in epoxy and enclosed in a metal housing, making the transmitter extremely durable and ensuring long-term reliability
- A compact size and two housing options allowing mounting flexibility for the control room or the field

Refer to the following literature for a full range of compatible connection heads, sensors, and thermowells provided by Emerson Process Management.

- Temperature Sensors and Assemblies Product Data Sheet, Volume 1 (document number 00813-0100-2654)
- Temperature Sensors and Assemblies Product Data Sheet, Volume 2 (document number 00813-0200-2654)

CONSIDERATIONS

General

Electrical temperature sensors such as RTDs and thermocouples produce low-level signals proportional to their sensed temperature. The 644 converts the low-level sensor signal to a standard 4–20 mA dc, digital HART, or digital Foundation fieldbus signal that is relatively insensitive to lead length and electrical noise. This signal is then transmitted to the control room via two wires.

Commissioning

The transmitter can be commissioned before or after installation. It may be useful to commission it on the bench, before installation, to ensure proper operation and to become familiar with its functionality. Make sure the instruments in the loop are installed in accordance with intrinsically safe, FISCO, or non-incendive field wiring practices.

Mechanical

Location

When choosing an installation location and position, take into account the need for access to the transmitter.

Special Mounting

Special mounting hardware is available for mounting a 644 head mount transmitter to a DIN rail, or assembling a new 644 head mount to an existing threaded sensor connection head (former option code L1).

Electrical

Proper electrical installation is necessary to prevent errors due to sensor lead resistance and electrical noise. For best results, shielded cable should be used in electrically noisy environments.

Make wiring connections through the cable entry in the side of the connection head. Be sure to provide adequate clearance for cover removal.

Environmental

The transmitter electronics module is permanently sealed within the housing, resisting moisture and corrosive damage. Verify that the operating atmosphere of the transmitter is consistent with the appropriate hazardous locations certifications.

Temperature Effects

The transmitter will operate within specifications for ambient temperatures between –40 and 185 °F (–40 and 85 °C). Heat from the process is transferred from the thermowell to the transmitter housing. If the expected process temperature is near or beyond specification limits, consider the use of additional thermowell lagging, and extension nipple, or a remote mounting configuration to isolate the transmitter from the process.

Figure 1-1 provides an example of the relationship between transmitter housing temperature rise and extension length.

Figure 1-1. 644 head mount Transmitter Connection Head Temperature Rise vs. Extension Length

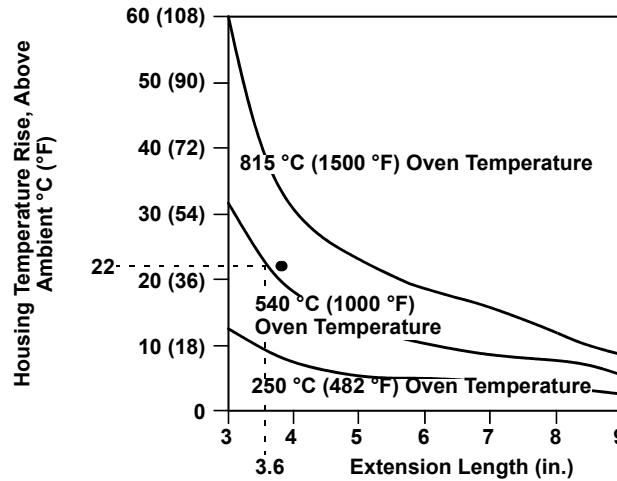

3044-0123A

Example

The transmitter specification limit is 85 °C. If the ambient temperature is 55 °C and the process temperature to be measured is 800 °C, the maximum permissible connection head temperature rise is the transmitter specification limit minus the ambient temperature (moves 85 to 55 °C), or 30 °C.

In this case, an extension of 100 mm meets this requirement, but 125 mm provides a margin of 8 °C, thereby reducing any temperature effects in the transmitter.

RETURN OF MATERIALS

To expedite the return process in North America, call the Emerson Process Management National Response Center toll-free at 800-654-7768. This center, available 24 hours a day, will assist you with any needed information or materials.

⚠ The center will ask for the following information:

- Product model
- Serial numbers
- The last process material to which the product was exposed

The center will provide

- A Return Material Authorization (RMA) number
- Instructions and procedures that are necessary to return goods that were exposed to hazardous substances

For other locations, please contact a Emerson Process Management sales representative.

NOTE

If a hazardous substance is identified, a Material Safety Data Sheet (MSDS), required by law to be available to people exposed to specific hazardous substances, must be included with the returned materials.

Section 2 Installation

Safety Messages	page 2-1
Mounting	page 2-3
Installation	page 2-4
Wiring	page 2-9
Power Supply	page 2-13

SAFETY MESSAGES

Instructions and procedures in this section may require special precautions to ensure the safety of the personnel performing the operations. Information that potentially raises safety issues is indicated by a warning symbol (⚠). Please refer to the following safety messages before performing an operation preceded by this symbol.

Warnings

⚠ WARNING

Failure to follow these installation guidelines could result in death or serious injury.

- Make sure only qualified personnel perform the installation.

Explosions could result in death or serious injury.

- Do not remove the connection head cover in explosive atmospheres when the circuit is live.
- Before connecting a HART Communicator in an explosive atmosphere, make sure the instruments in the loop are installed in accordance with intrinsically safe or non-incendive field wiring practices.
- Verify that the operating atmosphere of the transmitter is consistent with the appropriate hazardous locations certifications.
- All connection head covers must be fully engaged to meet explosion-proof requirements.

Process leaks could result in death or serious injury.

- Do not remove the thermowell while in operation.
- Install and tighten thermowells and sensors before applying pressure

Electrical shock could cause death or serious injury.

- Use extreme caution when making contact with the leads and terminals.

Figure 2-1. Installation Flowchart

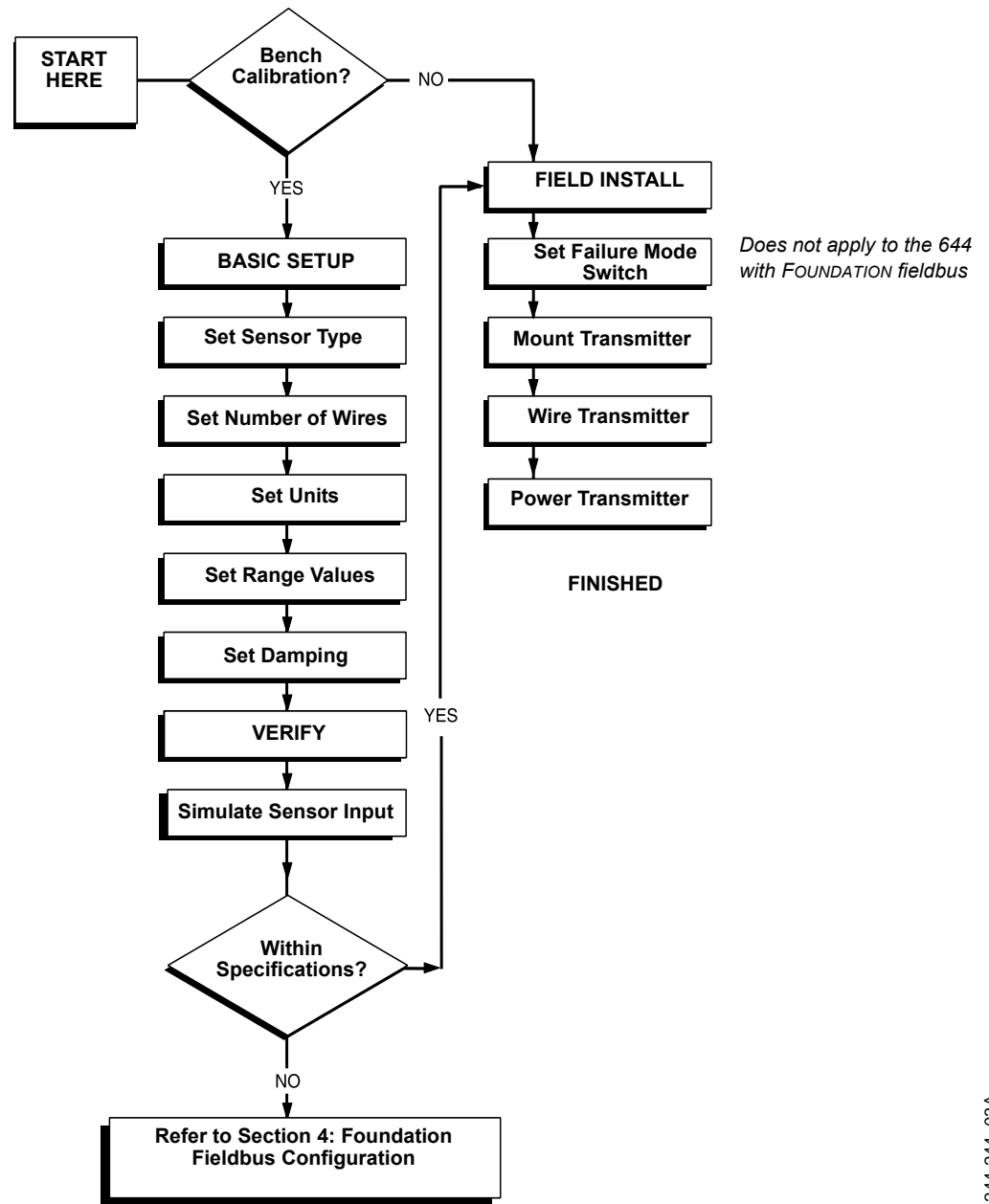

244-244_03A

MOUNTING

Mount the transmitter at a high point in the conduit run to prevent moisture from draining into the transmitter housing.

The 644 head mount installs

- In a connection head or universal head mounted directly on a sensor assembly
- Apart from a sensor assembly using a universal head
- To a DIN rail using an optional mounting clip.

The 644 rail mount attaches directly to a wall or to a DIN rail.

Mounting a 644H to a DIN Rail

To attach a head mount transmitter to a DIN rail, assemble the appropriate rail mounting kit (part number 00644-5301-0010) to the transmitter as shown in Figure 2-2. Follow the procedure under “Rail Mount Transmitter and Sensor (HART only)”.

Figure 2-2. Assembling Rail Clip Hardware to a 644H

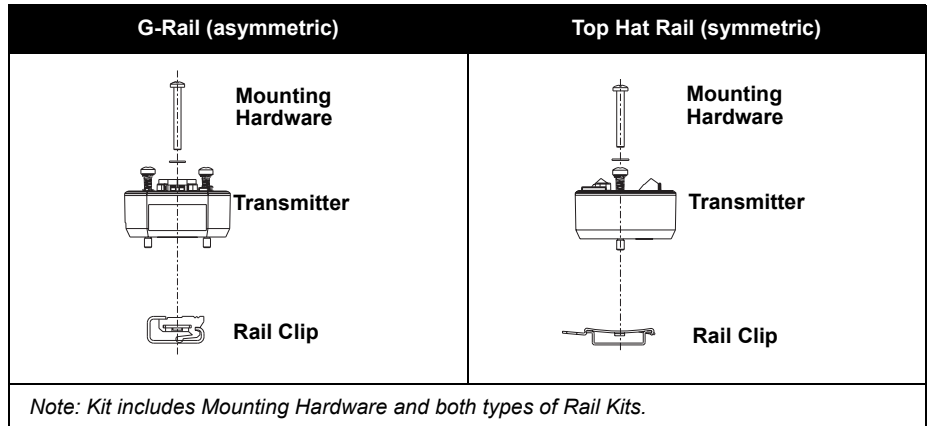

644-5302B01A, D02A

Retrofitting a 644H for Use in an Existing Threaded Sensor Connection Head

To mount a 644H in an existing threaded sensor connection head (former option code L1), order the 644H retrofit kit (part number 00644-5321-0010). The retrofit kit includes a new mounting bracket and all associated hardware necessary to facilitate the installation of the 644H in the existing head. See Figure 2-3.

Figure 2-3. Assembling 644H for Use in an Existing L1 Connection Head

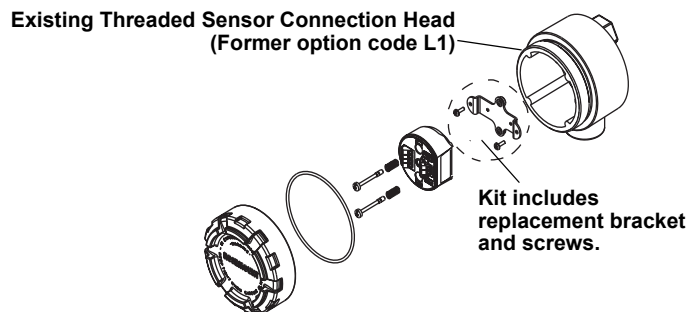

644-5321A01A

INSTALLATION

Typical European Installation

Head Mount Transmitter with DIN Plate Style Sensor (HART and FOUNDATION fieldbus)

- ⚠ 1. Attach the thermowell to the pipe or process container wall. Install and tighten the thermowell before applying process pressure.
2. Verify the transmitter failure mode switch (HART only).
3. Assemble the transmitter to the sensor. Push the transmitter mounting screws through the sensor mounting plate and insert the snap rings (optional) into the transmitter mounting screw groove.
4. Wire the sensor to the transmitter (see Figure 2-9 on page 2-11).
5. Insert the transmitter-sensor assembly into the connection head. Thread the transmitter mounting screw into the connection head mounting holes. Assemble the extension to the connection head. Insert the assembly into the thermowell.
6. Attach a cable gland into the shielded cable.
7. Insert the shielded cable leads into the connection head through the cable entry. Connect and tighten the cable gland.
- ⚠ 8. Connect the shielded power cable leads to the transmitter power terminals. Avoid contact with sensor leads and sensor connections.
- ⚠ 9. Install and tighten the connection head cover. Enclosure covers must be fully engaged to meet explosion-proof requirements.

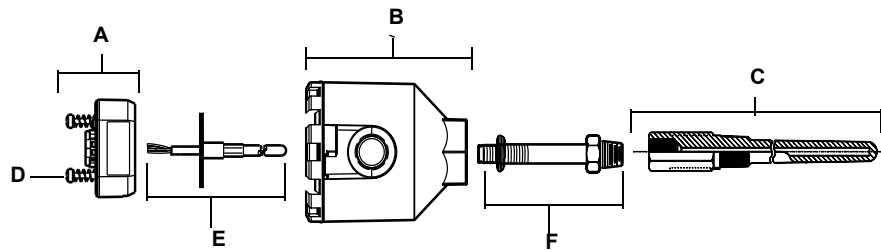

A = 644H Transmitter

B = Connection Head

C = Thermowell

D = Transmitter Mounting Screws

E = Integral Mount Sensor with Flying Leads

F = Extension

3144-0433QIG

Typical North American Installation

**Head Mount Transmitter with Threaded Sensor
(HART and FOUNDATION fieldbus)**

- ⚠ 1. Attach the thermowell to the pipe or process container wall. Install and tighten thermowells before applying process pressure.
- 2. Attach necessary extension nipples and adapters to the thermowell. Seal the nipple and adapter threads with silicone tape.
- 3. Screw the sensor into the thermowell. Install drain seals if required for severe environments or to satisfy code requirements.
- 4. Verify the transmitter failure mode switch (HART only).
- 5. Pull the sensor wiring leads through the universal head and transmitter. Mount the transmitter in the universal head by threading the transmitter mounting screws into the universal head mounting holes.
- 6. Mount the transmitter-sensor assembly into the thermowell. Seal adapter threads with silicone tape.
- 7. Install conduit for field wiring to the conduit entry of the universal head. Seal conduit threads with silicone tape.
- ⚠ 8. Pull the field wiring leads through the conduit into the universal head. Attach the sensor and power leads to the transmitter. Avoid contact with other terminals.
- ⚠ 9. Install and tighten the universal head cover. Enclosure covers must be fully engaged to meet explosion-proof requirements.

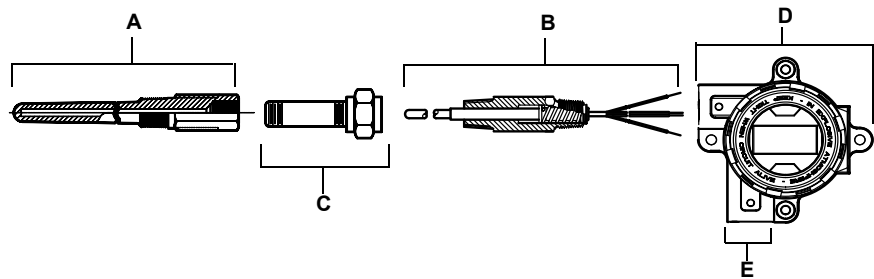

A = Threaded Thermowell
B = Threaded Style Sensor
C = Standard Extension
D = Universal Head
E = Conduit Entry

Rail Mount Transmitter and Sensor (HART only)

- ⚠ 1. Attach the transmitter to a suitable rail or panel.
- 2. Attach the thermowell to the pipe or process container wall. Install and tighten the thermowell, according to plant standards, before applying pressure.
- 3. Attach the sensor to the connection head and mount the entire assembly to the thermowell.
- 4. Attach and connect sufficient lengths of sensor lead wire from the connection head to the sensor terminal block.
- ⚠ 5. Tighten the connection head cover. Enclosure covers must be fully engaged to meet explosion-proof requirements.
- 6. Run sensor lead wires from the sensor assembly to the transmitter.
- 7. Verify the transmitter failure mode switch.
- ⚠ 8. Attach the sensor wires to the transmitter (see Figure 2-9 on page 2-11).

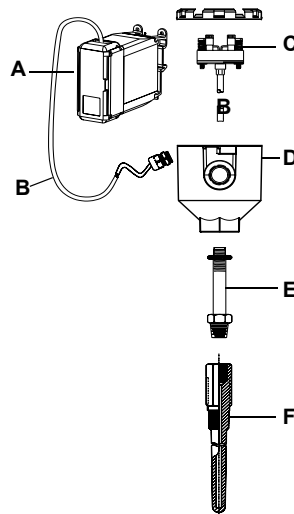

- A = Rail Mount Transmitter
- B = Sensor Leads with Cable Glands
- C = Integral Mount Sensor with Terminal Block
- D = Connection Head
- E = Standard Extension
- F = Threaded Thermowell

**Rail Mount Transmitter with Threaded Sensor
(HART only)**

- ⚠ 1. Attach the transmitter to a suitable rail or panel.
- 2. Attach the thermowell to the pipe or process container wall. Install and tighten the thermowell before applying pressure.
- 3. Attach necessary extension nipples and adapters. Seal the nipple and adapter threads with silicone tape.
- 4. Screw the sensor into the thermowell. Install drain seals if required for severe environments or to satisfy code requirements.
- 5. Screw the connection head to the sensor.
- 6. Attach the sensor lead wires to the connection head terminals.
- 7. Attach additional sensor lead wires from the connection head to the transmitter.
- ⚠ 8. Attach and tighten the connection head cover. Enclosure covers must be fully engaged to meet explosion-proof requirements.
- 9. Set the transmitter failure mode switch
- ⚠ 10. Attach the sensor wires to the transmitter (see Figure 2-9 on page 2-11).

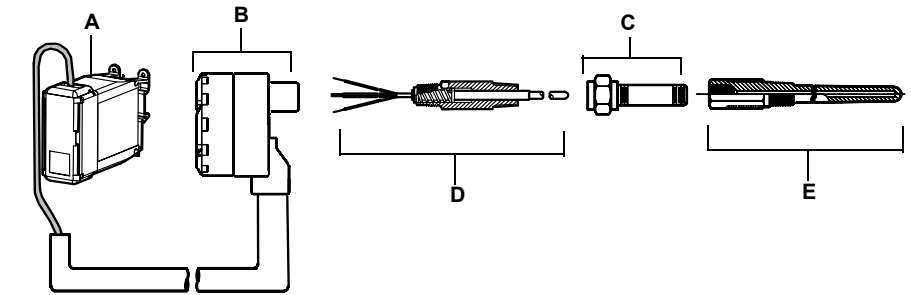

A = Rail Mount Transmitter
B = Threaded Sensor Connection Head
C = Standard Extension
D = Threaded Style Sensor
E = Threaded Thermowell

LCD Display Installation

The LCD display provides local indication of the transmitter output and abbreviated diagnostic messages governing transmitter operation. Transmitters ordered with the LCD display are shipped with the meter installed. After-market installation of the meter can be performed the transmitter has a meter connector (transmitter revision 5.5.2 or later). After-market installation requires the meter kit (part number 00644-4430-0001), which includes:

- LCD display assembly (includes LCD display, meter spacer, and 2 screws)
- Meter cover with O-ring in place

Figure 2-4. Installing the LCD Display

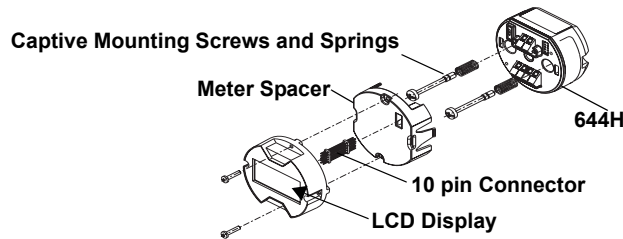

Use the following procedure to install the meter.

1. If the transmitter is installed in a loop, secure the loop and disconnect the power. If the transmitter is installed in an enclosure, remove the cover from the enclosure.
2. Decide meter orientation (the meter can be rotated in 90° increments). To change meter orientation, remove the screws located above and below the display screen. Lift the meter off the meter spacer. Remove the 8-pin plug and re-insert it in the location that will result in the desired viewing orientation.
3. Reattach the meter to the meter spacer using the screws. If the meter was rotated 90° from its original position it will be necessary to remove the screws from their original holes and re-insert them in the adjacent screws holes.
4. Line up the 10-pin connector with the 10-pin socket and push the meter into the transmitter until it snaps into place.
5. Attach the meter cover; tighten at least one-third turn after the O-ring contacts the transmitter housing. The cover must be fully engaged to meet explosion-proof requirements.
6. Use a HART Communicator, AMS software, or a FOUNDATION fieldbus Communication tool to configure the meter to the desired display. Refer to "LCD Meter Options (644H Only)" for information on configuring the LCD display.

NOTE

Observe the following LCD display temperature limits:
 Operating: -4 to 185 °F (-20 to 85 °C)
 Storage: -50 to 185 °F (-45 to 85 °C)

Multichannel Installations (HART)

In a HART installation, several transmitters can be connected to a single master power supply, as shown in Figure 2-5. In this case, the system may be grounded only at the negative power supply terminal. In multichannel installations where several transmitters depend on one power supply and the loss of all transmitters would cause operational problems, consider an uninterrupted power supply or a back-up battery. The diodes shown in Figure 2-5 prevent unwanted charging or discharging of the back-up battery.

Figure 2-5. Multichannel Installations

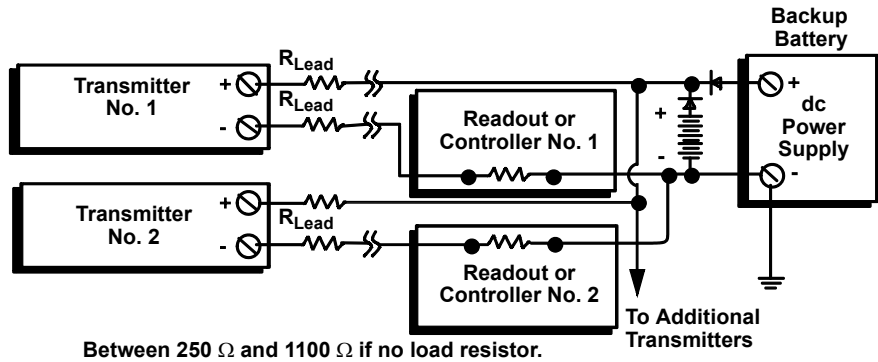

3044-0131A

WIRING

- ⚠ All power to the transmitter is supplied over the signal wiring. Use ordinary copper wire of sufficient size to ensure that the voltage across the transmitter power terminals does not drop below 12.0 V dc for HART or 9 V dc for Foundation fieldbus.
- ⚠ If the sensor is installed in a high-voltage environment and a fault condition or installation error occurs, the sensor leads and transmitter terminals could carry lethal voltages. Use extreme caution when making contact with the leads and terminals.

NOTE

Do not apply high voltage (e.g., ac line voltage) to the transmitter terminals. Abnormally high voltage can damage the unit. (Sensor and transmitter power terminals are rated to 42.4 V dc. A constant 42.4 volts across the sensor terminals may damage the unit.)

For multichannel HART installations, see above. The transmitters will accept inputs from a variety of RTD and thermocouple types. Refer to Figure 2-6 on page 2-10 when making sensor connections. Refer to Figure 2-8 on page 2-10 for FOUNDATION fieldbus installations.

Use the following steps to wire the power and sensor to the transmitter:

1. Remove the terminal block cover (if applicable).
2. Connect the positive power lead to the "+" terminal. Connect the negative power lead to the "-" terminal (see Figure 2-7).
3. Tighten the terminal screws. When tightening the sensor and power wires, the max torque is 6-in.-lbs (0.7 N-m).
4. Reattach and tighten the cover (if applicable).
5. Apply power (see "Power Supply").

Figure 2-6. Transmitter Power, Communication, and Sensor Terminals

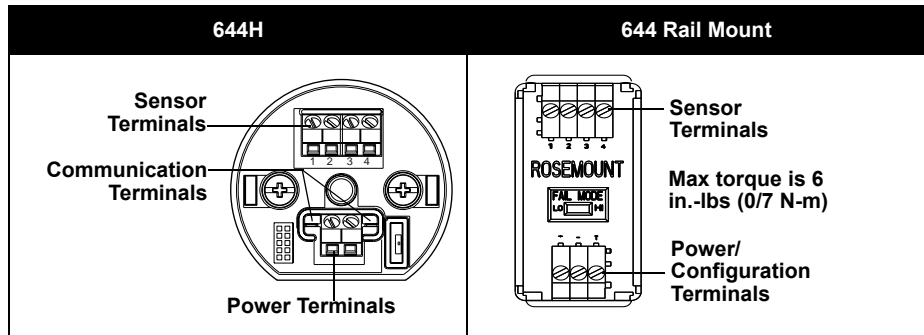

Figure 2-7. Connecting a HART Communication Tool to a Transmitter Loop

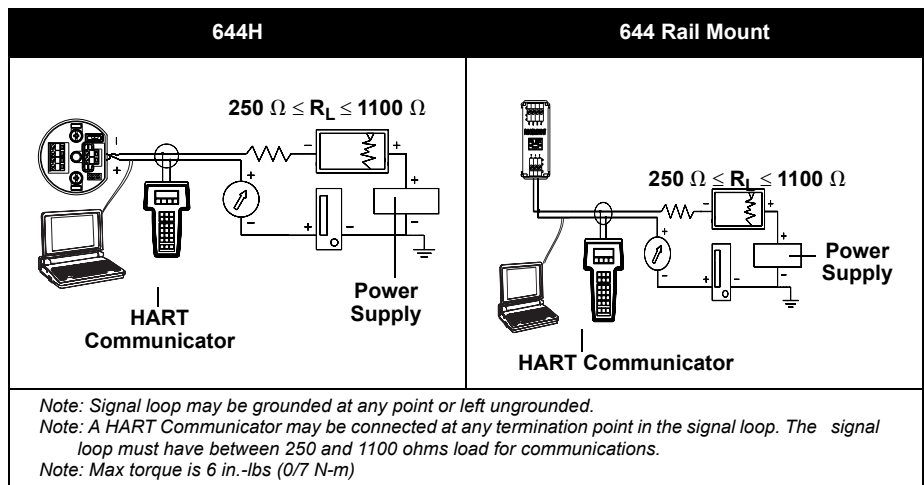
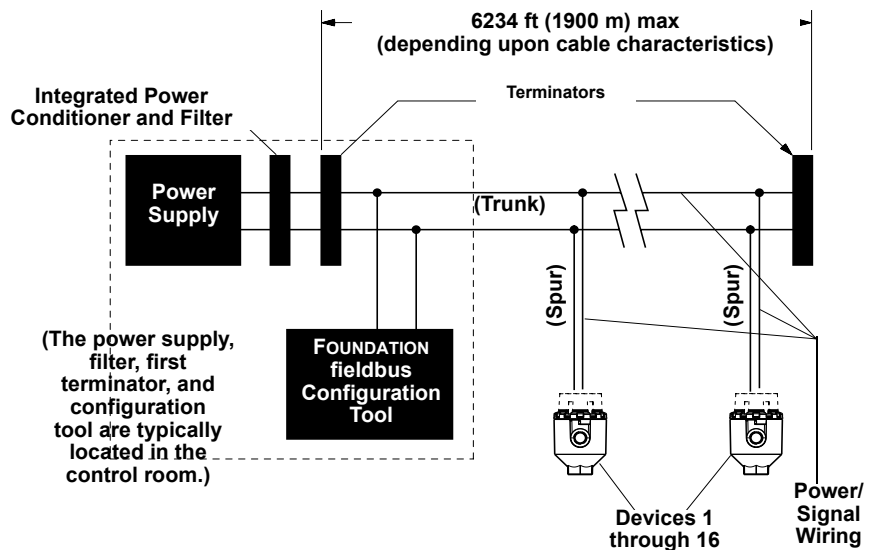

Figure 2-8. Connecting a FOUNDATION fieldbus Host System to a Transmitter Loop



Sensor Connections

 The 644 is compatible with a number of RTD and thermocouple sensor types. Figure 2-9 shows the correct input connections to the sensor terminals on the transmitter. To ensure a proper sensor connection, anchor the sensor lead wires into the appropriate compression terminals and tighten the screws.

Figure 2-9. Sensor Wiring Diagrams



* Emerson Process Management provides 4-wire sensors for all single element RTDs. Use these RTDs in 3-wire configurations by leaving the unneeded leads disconnected and insulated with electrical tape.

Thermocouple or Millivolt Inputs

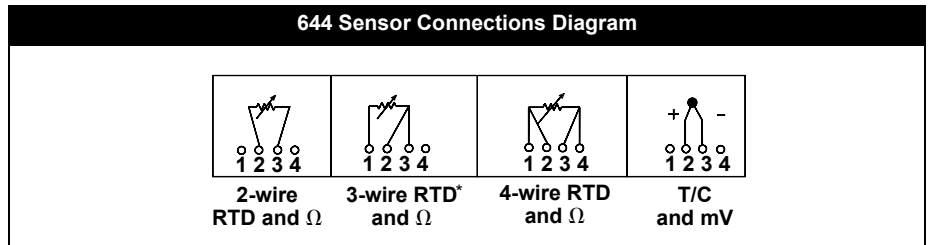
The thermocouple can be connected directly to the transmitter. Use appropriate thermocouple extension wire if mounting the transmitter remotely from the sensor. Make millivolt inputs connections with copper wire. Use shielding for long runs of wire.

RTD or Ohm Inputs

The transmitters will accept a variety of RTD configurations, including 2-wire, 3-wire, 4-wire. If the transmitter is mounted remotely from a 3-wire or 4-wire RTD, it will operate within specifications, without recalibration, for lead wire resistances of up to 60 ohms per lead (equivalent to 6,000 feet of 20 AWG wire). In this case, the leads between the RTD and transmitter should be shielded. If using only two leads, both RTD leads are in series with the sensor element, so significant errors can occur if the lead lengths exceed three feet of 20 AWG wire (approximately 0.05 °C/ft). For longer runs, attach a third or fourth lead as described above.

Sensor Lead Wire Resistance Effect– RTD Input

When using a 4-wire RTD, the effect of lead resistance is eliminated and has no impact on accuracy. However, a 3-wire sensor will not fully cancel lead resistance error because it cannot compensate for imbalances in resistance between the lead wires. Using the same type of wire on all three lead wires will make a 3-wire RTD installation as accurate as possible. A 2-wire sensor will produce the largest error because it directly adds the lead wire resistance to the sensor resistance. For 2- and 3-wire RTDs, an additional lead wire resistance error is induced with ambient temperature variations. The table and the examples shown below help quantify these errors.

Table 2-1. Examples of Approximate Basic Error

Sensor Input	Approximate Basic Error
4-wire RTD	None (independent of lead wire resistance)
3-wire RTD	± 1.0 Ω in reading per ohm of unbalanced lead wire resistance (Unbalanced lead wire resistance = maximum imbalance between any two leads.)
2-wire RTD	1.0 Ω in reading per ohm of lead wire resistance

Examples of Approximate Lead Wire Resistance Effect Calculations

Given:

Total cable length:	150 m
Imbalance of the lead wires at 20 °C:	1.5 Ω
Resistance/length (18 AWG Cu):	0.025 Ω/m °C
Temperature coefficient of Cu (α_{Cu}):	0.039 Ω/Ω °C
Temperature coefficient of Pt(α_{Pt}):	0.00385 Ω/Ω °C
Change in Ambient Temperature (ΔT_{amb}):	25 °C
RTD Resistance at 0 °C (R_0):	100 Ω (for Pt 100 RTD)

- Pt100 4-wire RTD: No lead wire resistance effect.
- Pt100 3-wire RTD:

$$\text{Basic Error} = \frac{\text{Imbalance of Lead Wires}}{(\alpha_{Pt} \times R_0)}$$

$$\text{Error due to amb. temp. variation} = \frac{(\alpha_{Cu}) \times (\Delta T_{amb}) \times (\text{Imbalance of Lead Wires})}{(\alpha_{Pt}) \times (R_0)}$$

Lead wire imbalance seen by the transmitter = 0.5 Ω

$$\text{Basic error} = \frac{0.5 \Omega}{(0.00385 \Omega / \Omega \text{ } ^\circ\text{C}) \times (100 \Omega)} = 1.3 \text{ } ^\circ\text{C}$$

Error due to amb. temp. var. of ± 25 °C

$$= \frac{(0.0039 \Omega / \Omega \text{ } ^\circ\text{C}) \times (25 \text{ } ^\circ\text{C}) \times (0.5 \Omega)}{(0.00385 \Omega / \Omega \text{ } ^\circ\text{C}) \times (100 \Omega)} = \pm 13 \text{ } ^\circ\text{C}$$

- Pt100 2-wire RTD:

$$\text{Basic Error} = \frac{\text{Lead Wire Resistance}}{(\alpha_{Pt} \times R_0)}$$

$$\text{Error due to amb. temp. variation} = \frac{(\alpha_{Cu}) \times (\Delta T_{amb}) \times (\text{Lead Wire Resistance})}{(\alpha_{Pt}) \times (R_0)}$$

Lead wire resistance seen by the transmitter = 150 m × 2 wires × 0.025 Ω/m = 7.5 Ω

$$\text{Basic error} = \frac{7.5 \Omega}{(0.00385 \Omega / \Omega \text{ } ^\circ\text{C}) \times (100 \Omega)} = 19.5 \text{ } ^\circ\text{C}$$

Error due to amb. temp. var. of ± 25 °C

$$= \frac{(0.0039 \Omega / \Omega \text{ } ^\circ\text{C}) \times (25 \text{ } ^\circ\text{C}) \times (7.5 \Omega)}{(0.00385 \Omega / \Omega \text{ } ^\circ\text{C}) \times (100 \Omega)} = \pm 1.9 \text{ } ^\circ\text{C}$$

POWER SUPPLY

HART Installation

To communicate with a transmitter, a 18.1 V dc minimum power supply is required. The power supplied to the transmitter should not drop below the transmitter lift-off voltage (see Figure 2-10). If the power drops below the lift-off voltage while the transmitter is being configured, the transmitter may interpret the configuration information incorrectly.

The dc power supply should provide power with less than 2 percent ripple. The total resistance load is the sum of the resistance of the signal leads and the load resistance of any controller, indicator, or related pieces of equipment in the loop. Note that the resistance of intrinsic safety barriers, if used, must be included.

Figure 2-10. Load Limits

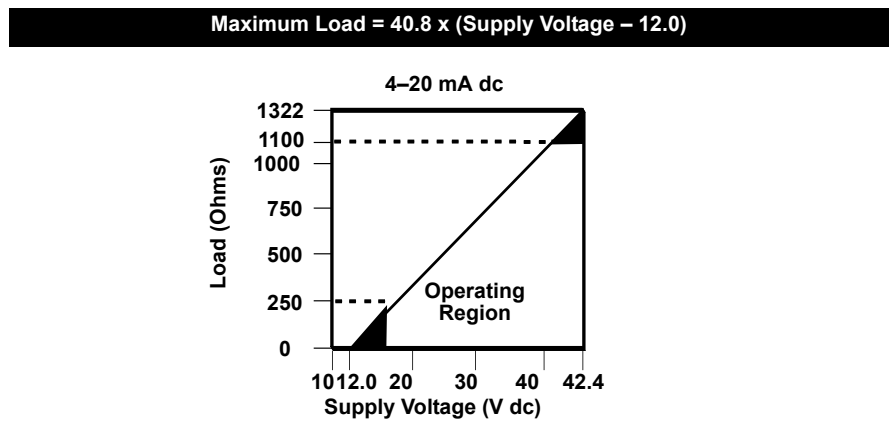

644_08A

FOUNDATION fieldbus Installation

Powered over FOUNDATION fieldbus with standard fieldbus power supplies. The transmitter operates between 9.0 and 32.0 V dc, 11 mA maximum. Transmitter power terminals are rated to 42.4 VDC.

The power terminals on the 644 with FOUNDATION fieldbus are polarity insensitive.

Ground the Transmitter

The transmitter will operate with the current signal loop either floating or grounded. However, the extra noise in floating systems affects many types of readout devices. If the signal appears noisy or erratic, grounding the current signal loop at a single point may solve the problem. The best place to ground the loop is at the negative terminal of the power supply. Do not ground the current signal loop at more than one point.

The transmitter is electrically isolated to 500 V DC/AC rms (707 V dc), so the input circuit may also be grounded at any single point. When using a grounded thermocouple, the grounded junction serves as this point.

Neither side of the loop should be grounded on FOUNDATION fieldbus devices. Only the shield wire should be grounded.

NOTE

Do not ground the signal wire at both ends.

Ungrounded Thermocouple, mV, and RTD/Ohm Inputs

Each process installation has different requirements for grounding. Use the grounding options recommended by the facility for the specific sensor type, or begin with grounding Option 1 (the most common).

Option 1:

1. Connect signal wiring shield to the sensor wiring shield.
2. Ensure the two shields are tied together and electrically isolated from the transmitter housing.
3. Ground shield at the power supply end only.
4. Ensure that the sensor shield is electrically isolated from the surrounding grounded fixtures.

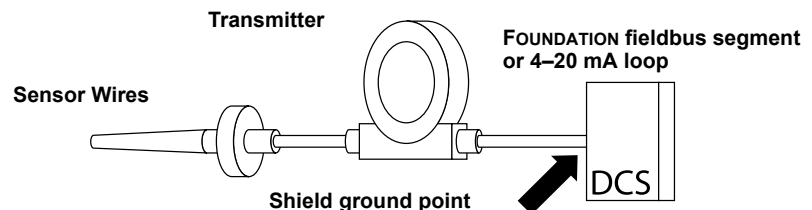

Connect shields together, electrically isolated from the transmitter

Option 2:

1. Connect sensor wiring shield to the transmitter housing (only if the housing is grounded).
2. Ensure the sensor shield is electrically isolated from surrounding fixtures that may be grounded.
3. Ground signal wiring shield at the power supply end.

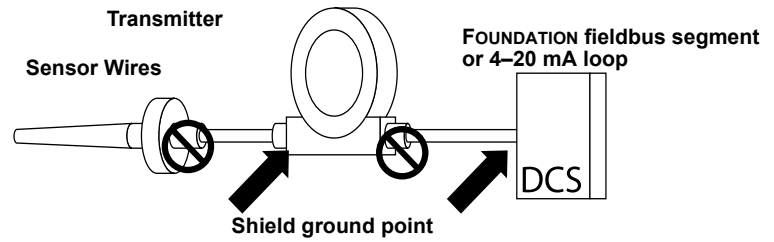

Option 3:

1. Ground sensor wiring shield at the sensor, if possible.
2. Ensure that the sensor wiring and signal wiring shields are electrically isolated from the transmitter housing.
3. Do not connect the signal wiring shield to the sensor wiring shield.
4. Ground signal wiring shield at the power supply end.

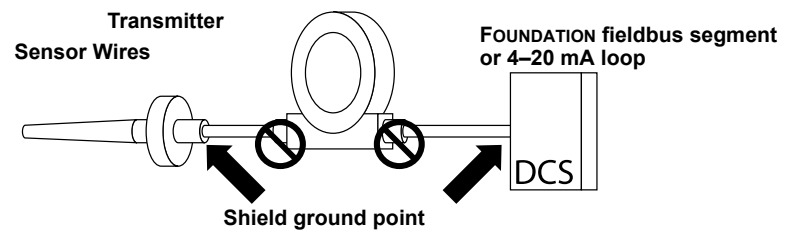

Grounded Thermocouple Inputs

1. Ground sensor wiring shield at the sensor.
2. Ensure that the sensor wiring and signal wiring shields are electrically isolated from the transmitter housing.
3. Do not connect the signal wiring shield to the sensor wiring shield.
4. Ground signal wiring shield at the power supply end.

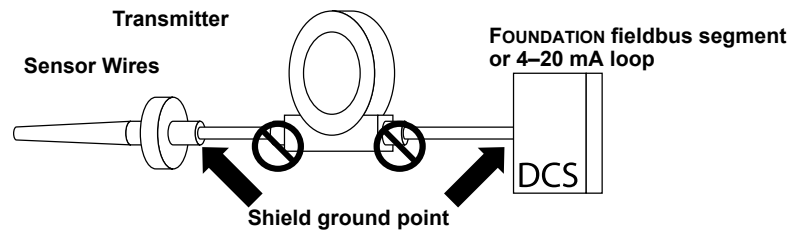

Section 3

HART Configuration

Overview	page 3-1
Safety Messages	page 3-1
HART Communicator	page 3-3
Configuration	page 3-3
Multidrop Communication	page 3-18
Operation and Maintenance	page 3-19

OVERVIEW

This section provides information on configuring, troubleshooting, operating, and maintaining the Rosemount 644 with HART protocol.

SAFETY MESSAGES

Instructions and procedures in this section may require special precautions to ensure the safety of the personnel performing the operations. Information that potentially raises safety issues is indicated by a warning symbol (⚠). Please refer to the following safety messages before performing an operation preceded by this symbol.

Warnings

⚠ WARNING

Failure to follow these installation guidelines could result in death or serious injury.

- Make sure only qualified personnel perform the installation.

Explosions could result in death or serious injury.

- Do not remove the connection head cover in explosive atmospheres when the circuit is live.
- Before connecting a HART Communicator in an explosive atmosphere, make sure the instruments in the loop are installed in accordance with intrinsically safe or non-incendive field wiring practices.
- Verify that the operating atmosphere of the transmitter is consistent with the appropriate hazardous locations certifications.
- All connection head covers must be fully engaged to meet explosion-proof requirements.

Process leaks could result in death or serious injury.

- Do not remove the thermowell while in operation.
- Install and tighten thermowells and sensors before applying pressure

Electrical shock could cause death or serious injury.

- Use extreme caution when making contact with the leads and terminals.

Rosemount 644

HART

Surges/Transients

The transmitter will withstand electrical transients of the energy level encountered in static discharges or induced switching transients. However, high-energy transients, such as those induced in wiring from nearby lightning strikes, welding, heavy electrical equipment, or switching gears, can damage both the transmitter and the sensor. To protect against high-energy transients, install the transmitter into a suitable connection head with the Rosemount 470 Transient Protector. Refer to the 470 Transient Protector Product Data Sheet (document number 00813-0100-4191) for more information.

COMMISSIONING

The 644 must be configured for certain basic variables to operate. In many cases, all of these variables are pre-configured at the factory. Configuration may be required if the transmitter is not configured or if the configuration variables need revision.

Commissioning consists of testing the transmitter and verifying transmitter configuration data. Model 644 transmitters can be commissioned either before or after installation. Commissioning the transmitter on the bench before installation using a HART Communicator or AMS ensures that all transmitter components are in working order.

⚠ To commission on the bench, connect the transmitter and the HART Communicator or AMS as shown in Figure 2-7 on page 2-10. Make sure the instruments in the loop are installed according to intrinsically-safe or non-incendive field wiring practices before connecting a communication in an explosive atmosphere. Connect HART Communication leads at any termination point in the signal loop. For convenience, connect them to the terminals labeled “COMM” on the terminal block. Connecting across the “TEST” terminals will prevent successful communication. Avoid exposing the transmitter electronics to the plant environment after installation by setting all transmitter jumpers during the commissioning stage on the bench.

When using a HART Communicator, any configuration changes made must be sent to the transmitter by using the “Send” key (F2). AMS configuration changes are implemented when the “Apply” button is clicked.

For more information on using the HART Communicator with the 644 transmitter, see Section 3: HART Configuration.

Setting the Loop to Manual

When sending or requesting data that would disrupt the loop or change the output of the transmitter, set the process application loop to manual. The HART Communicator or AMS will prompt you to set the loop to manual when necessary. Acknowledging this prompt does not set the loop to manual. The prompt is only a reminder; set the loop to manual as a separate operation.



Failure Mode

As part of normal operation, each transmitter continuously monitors its own performance. This automatic diagnostics routine is a timed series of checks repeated continuously. If diagnostics detect an input sensor failure or a failure in the transmitter electronics, the transmitter drives its output to low or high depending on the position of the failure mode switch. Saturation levels are 3.90 mA for standard configuration (3.8 mA if configured for NAMUR-compliant operation) on the low end and 20.5 mA for standard or NAMUR-compliant configuration on the high end, if the sensor temperature is outside of range limits. These values are also custom configurable by the factory or using the HART Communicator.

The values to which the transmitter drives its output in failure mode depend on whether it is configured to standard, NAMUR-compliant, or custom operation. See “Hardware and Software Failure Mode” on page A-7 for standard and NAMUR-compliant operation parameters.

Changing Switch Positions

To change the failure mode on the 644 transmitter, follow the steps below.

-  1. If applicable, remove the enclosure cover.
- 2. Locate the orange failure mode switch. On the 644H the switch is located near the power terminals and located in the center of the front panel on the 644 rail mount (see Figure 2-6).
- 3. Move the switch to the desired alarm setting. To set the failure mode to high alarm, position the switch toward the “HI” mark on the terminal block. To set the failure mode to low alarm, position the switch in the opposite direction.
-  4. Replace the enclosure cover (if applicable). Enclosure covers must be fully engaged to meet explosion-proof requirements.

HART COMMUNICATOR

The HART Communicator exchanges information with the transmitter from the control room, the instrument site, or any wiring termination point in the loop. To facilitate communication, connect the HART Communicator in parallel with the transmitter (see Figure 2-11). Use the loop connection ports on the rear panel of the HART Communicator. The connections are non-polarized. Do not make connections to the serial port or the NiCad recharger jack in explosive atmospheres. Before connecting the HART communicator in an explosive atmosphere, make sure the instruments in the loop are installed in accordance with intrinsically safe or non-incendive field wiring practices.

For more information regarding the HART Communicator, please see the HART Communicator Reference Manual (document number 00809-0100-4275)

CONFIGURATION

The 644 transmitter can be configured either on-line or off-line using a HART Communicator or AMS. During on-line configuration, the transmitter is connected to a HART communicator. Data is entered in the working register of the communicator and sent directly to the transmitter. Off-line configuration consists of storing configuration data in a HART Communicator while it is not connected to a transmitter. Data is stored in nonvolatile memory and can be downloaded to the transmitter at a later time.

Rosemount 644

HART Menu Tree

Options listed in bold type indicate that a selection provides other options. For ease of operation, changing calibration and setup, such as sensor type, number of wires, and range values, can be completed in several locations.

Figure 3-1. HART Communicator Menu Tree

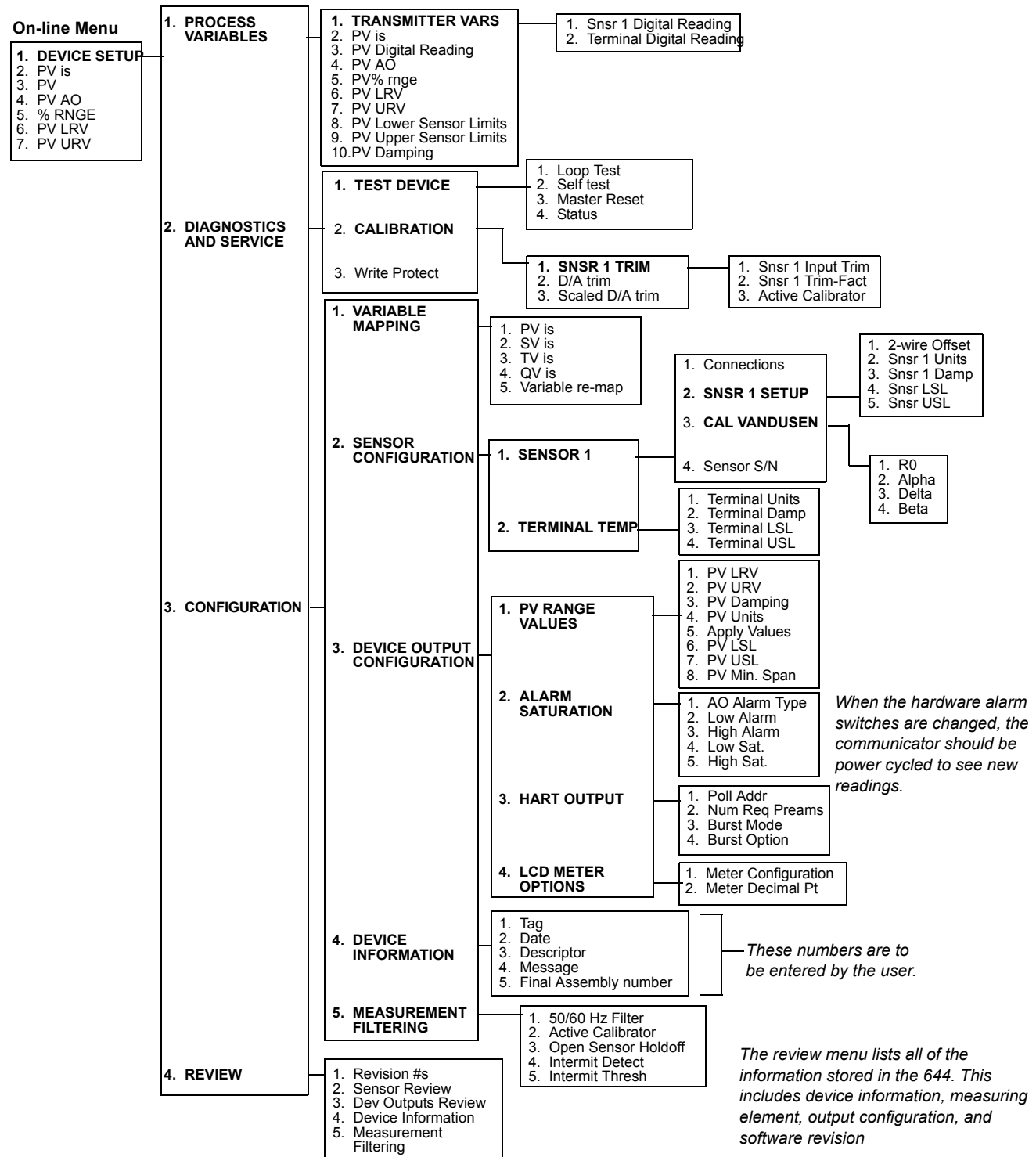

Fast Key Sequence

Table 3-1 lists the fast key sequences for common transmitter functions.

NOTE:

The fast key sequences assume that DD Dev v6, DD v1 is being used. Some features apply only to the 644H, as noted in the following pages. Table 3-1 provides alphabetical function lists for all HART Communicator tasks as well as their corresponding fast key sequences.

Table 3-1. 644 Fast Key Sequence

Function	Fast Keys
Active Calibrator	1, 2, 2, 1, 3
Alarm/Saturation	1, 3, 3, 2
AO Alarm Type	1, 3, 3, 2, 1
Burst Mode	1, 3, 3, 3, 3
Burst Option	1, 3, 3, 3, 4
Calibration	1, 2, 2
Callendar-Van Dusen	1, 3, 2, 1
Configuration	1, 3
D/A Trim	1, 2, 2, 2
Damping Values	1, 1, 10
Date	1, 3, 4, 2
Descriptor	1, 3, 4, 3
Device Info	1, 3, 4
Device Output Configuration	1, 3, 3
Diagnostics and Service	1, 2
Filter 50/60 Hz	1, 3, 5, 1
Hardware Rev	1, 4, 1
Hart Output	1, 3, 3, 3
Intermittent Detect	1, 3, 5, 4
LCD Display Options	1, 3, 3, 4
Loop Test	1, 2, 1, 1
LRV (Lower Range Value)	1, 1, 6
LSL (Lower Sensor Limit)	1, 1, 8
Measurement Filtering	1, 3, 5
Message	1, 3, 4, 4
Meter Configuring	1, 3, 3, 4, 1
Meter Decimal Point	1, 3, 3, 4, 2

Function	Fast Key
Num Req Preams	1, 3, 3, 3, 2
Open Sensor Holdoff	1, 3, 5, 3
Percent Range	1, 1, 5
Poll Address	1, 3, 3, 3, 1
Process Temperature	1, 1
Process Variables	1, 1
PV Damping	1, 3, 3, 1, 3
PV Unit	1, 3, 3, 1, 4
Range Values	1, 3, 3, 1
Review	1, 4
Scaled D/A Trim	1, 2, 2, 3
Sensor Connection	1, 3, 2, 1, 1
Sensor 1 Setup	1, 3, 2, 1, 2
Sensor Serial Number	1, 3, 2, 1, 4
Sensor 1 Trim	1, 2, 2, 1
Sensor 1 Trim-Factory	1, 2, 2, 1, 2
Sensor Type	1, 3, 2, 1, 1
Software Revision	1, 4, 1
Status	1, 2, 1, 4
Tag	1, 3, 4, 1
Terminal Temperature	1, 3, 2, 2,
Test Device	1, 2, 1
URV (Upper Range Value)	1, 1, 7
USL (Upper Sensor Limit)	1, 1, 9
Variable Mapping	1, 3, 1
Variable Re-Map	1, 3, 1, 5
Write Protect	1, 2, 3
2-Wire Offset	1, 3, 2, 1, 2, 1



Rosemount 644

HART

AMS

One of the key benefits of intelligent devices is the ease of device configuration. When used with AMS, the 644 is easy to configure and provides instant and accurate alerts and alarms. The main configuration screen of the 644 is the “Configuration Properties” screen. From this screen, the transmitter set-up can easily be viewed and edited.

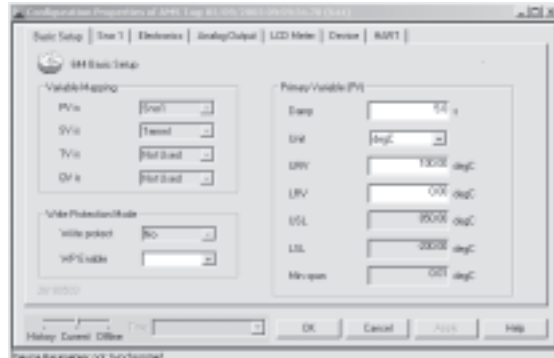

The screens use a color-coding to give visual indication of the transmitter health and to indicate any changes that may need to be made or written to the transmitter.

- Gray screens: indicates that all information has been written to the transmitter
- Yellow on screen: changes have been made in the software but not sent to the transmitter
- Green on screen: all current changes on screen have been written to the transmitter
- Red on screen: indicates an alarm or alert that requires immediate investigation

Apply AMS Changes

Changes made in the software must be *sent* to the transmitter in order for the changes to take effect in the process.

1. From the bottom of the “Configuration Properties” screen, click **Apply**.
2. An “Apply Parameter Modification” screen appears, enter desired information and click **OK**.
3. After carefully reading the warning provided, select **OK**.



Review Configuration Data

Before operating the 644 in an actual installation, review all of the factory-set configuration data to ensure that it reflects the current application.

Review

Fast Key Sequence	1, 4
-------------------	------

When activating the *Review* function, scroll through the configuration data list to check each process variable. If changes to the transmitter configuration data are necessary, refer to “Configuration” below.

AMS

Right click on the device and select “Configuration Properties” from the menu. Select the tabs to review the transmitter configuration data.

Check Output

Before performing other transmitter on-line operations, review the 644 digital output parameters to ensure that the transmitter is operating properly.

Process Variables

Fast Key Sequence	1, 1
-------------------	------

The *Process Variables* menu displays process variables, including sensor temperature, percent of range, analog output, and terminal temperature. These process variables are continuously updated. The primary variable is the 4 –20 mA analog signal. The secondary variable is the transmitter terminal temperature.

AMS

Right click on the device and select “Configuration Properties” from the menu. Select the Analog Output tab to review the transmitter Analog Output Range.

Configuration

The 644 must be configured for certain basic variables in order to be operational. In many cases, all of these variables are pre-configured at the factory. Configuration may be required if the transmitter is not configured or if the configuration variables need revision.

Variable Mapping

Fast Key Sequence	1, 3, 1
-------------------	---------

The *Variable Mapping* menu displays the sequence of the process variables. When using the 644H you can select *5 Variable Re-Map* to change this configuration. When the *Select PV* screen appears *Snsr 1* must be selected. Either *Sensor 1*, *Terminal Temperature*, or *not used* can be selected for the remaining variables. The primary variable is the 4–20 mA analog signal.

AMS

Right click on the device and select “Configuration Properties” from the menu. Select the Analog Output tab to review the Mapped Variable Output.

Apply changes made (see “Apply AMS Changes” on page 3-6).

Select Sensor Type

Fast Key Sequence	1, 3, 2, 1, 1
-------------------	---------------

The *Connections* command allows selection of the sensor type and the number of sensor wires to be connected. Select from the following sensors:

- 2-, 3-, or 4-wire Pt 100, Pt 200, Pt 500, Pt 1000 RTDs: $\alpha = 0.00385 \Omega/\Omega/^\circ\text{C}$
- 2-, 3-, or 4-wire Pt 100: $\alpha = 0.003916 \Omega/\Omega/^\circ\text{C}$
- 2-, 3-, or 4-wire Ni 120 nickel RTDs
- 2-, 3-, or 4-wire Cu 10 RTDs
- IEC/NIST/DIN Type B, E, J, K, R, S, T thermocouples
- DIN type L, U thermocouples
- ASTM Type W5Re/W26Re thermocouple
- -10 to 100 millivolts
- 2-, 3-, or 4-wire 0 to 2000 ohms

Contact a Emerson Process Management representative for information on the temperature sensors, thermowells, and accessory mounting hardware that is available through Emerson Process Management.

AMS

Right click on the device and select “Sensor Connections,” then select “Sensor 1 Config.” Select “Sensor Connections.” The *wizard* will walk through the screens.

Sensor Serial Number

Fast Key Sequence	1, 3, 2, 1, 4
-------------------	---------------

The *Sensor S/N* variable provides a location to list the serial number of the attached sensor. It is useful for identifying sensors and tracking sensor calibration information.

AMS

Right click on the device and select “Configuration Properties” from the menu. Select the Snsr 1 tab to configure the Snsr S/N.

Apply changes made (see “Apply AMS Changes” on page 3-6).

Set Output Units

Fast Key Sequence	1, 3, 2, 1, 2, 2
-------------------	------------------

The *Set Output Unit* command sets the desired primary variable units. Set the transmitter output to one of the following engineering units:

- Degrees Celsius
- Degrees Fahrenheit
- Degrees Rankine
- Kelvin
- Ohms
- Millivolts



AMS

Right click on the device and select “Configuration Properties” from the menu. Select the Snsr 1 tab to configure the Sensor Output Units. Set the units to the desired output.

Apply changes made (see “Apply AMS Changes” on page 3-6).

50/60 Hz Filter

Fast Key Sequence	1, 3, 5, 1
-------------------	------------

The *50/60 Hz Filter* command sets the transmitter electronic filter to reject the frequency of the AC power supply in the plant.

AMS

Right click on the device and select “Configuration Properties” from the menu. Select the Electronics tab to configure the output frequency.

Apply changes made (see “Apply AMS Changes” on page 3-6).

Terminal Temperature

Fast Key Sequence	1, 3, 2, 2
-------------------	------------

The *Terminal Temp* command sets the terminal temperature units to indicate the temperature at the transmitter terminals.

AMS

Right click on the device and select “Configuration Properties” from the menu. Select the Electronics tab to configure the Terminal Temperature. In the Terminal Temperature box, set the Terminal Units to the desired output.

Apply changes made (see “Apply AMS Changes” on page 3-6).

LCD Meter Options (644H Only)

Fast Key Sequence	1, 3, 3, 4
-------------------	------------

The *LCD Meter Option* command sets the meter options, including engineering units and decimal point. Change the meter settings to reflect necessary configuration parameters when adding a meter or reconfiguring the transmitter.

To customize variables that the meter displays, follow the steps below:

1. From the home screen select *1 Device Setup, 3 Configuration, 3 Dev Output Config, 4 LCD Meter Options, and 1 Meter Config.*
2. Use the F2 key to turn each of the following options **OFF** or **ON**: Sensor 1, Terminal Temp, Percent Of Range, Analog Output. As many outputs as desired can be turned **ON** at once.
3. Press F4, **ENTER**, and then F2, **SEND**, to send the information to the transmitter. The LCD display will scroll through the outputs selected in step 2.

To change the decimal point configuration, perform the following steps:

1. From the home screen select *1 Device Setup, 3 Configuration, 3 Dev Output Config, 4 LCD Meter Options, and 1 Meter Decimal Pt.*
2. Choose from *Floating Precision* or *One-, Two-, Three-, or Four-Digit Precision* by pressing F4, **ENTER**. Press F2 to send the information to the transmitter.

AMS

Right click on the device and select “Configuration Properties” from the menu. Select the Device tab to configure the LCD. From the LCD Meter box, define the Meter Config, Meter Decimal Pt.

Apply changes made (see “Apply AMS Changes” on page 3-6).

Process Variable (PV) Damping

Fast Key Sequence	1, 3, 3, 1, 3
-------------------	---------------

The *PV Damp* command changes the response time of the transmitter to smooth variations in output readings caused by rapid changes in input. Determine the appropriate damping setting based on the necessary response time, signal stability, and other requirements of the loop dynamics of the system. The default damping value is 5.0 seconds and can be reset to any value between 0 and 32 seconds.

The value chosen for damping affects the response time of the transmitter. When set to zero (or disabled), the damping function is off and the transmitter output reacts to changes in input as quickly as the intermittent sensor algorithm allows (refer to “Intermittent Threshold” on page 3-16 for a description of the intermittent sensor algorithm). Increasing the damping value increases the transmitter response time.

With damping enabled, if the temperature change is within 0.2% of the sensor limits, the transmitter measures the change in input every 500 milliseconds and outputs values according to the following relationship:

$$\text{Damped Value} = (N - P) \times \left(\frac{2T - U}{2T + U} \right) + P$$

P =previous damped value
N =new sensor value
T = damping time constant

At the value to which the damping time constant is set, the transmitter output is at 63% of the input change and it continues to approach the input according to the damping equation above.

For example, as illustrated in Figure 3-2, if the temperature undergoes a step change—within 0.2% of the sensor limits—from 100 degrees to 110 degrees, and the damping is set to 5.0 seconds, the transmitter calculates and reports a new reading every 500 milliseconds using the damping equation. At 5.0 seconds, the transmitter outputs 106.3 degrees, or 63% of the input change, and the output continues to approach the input curve according to the equation above.

For information regarding the damping function when the input change is greater than 0.2% of the sensor limits, refer to “Intermittent Threshold” on page 3-16.

Figure 3-2. Change in Input vs. Change in Output with Damping Set to Five Seconds

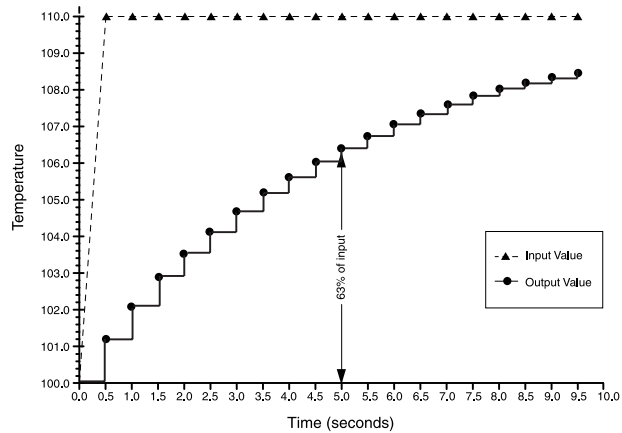

644-644_01A

HART

AMS

Right click on the device and select “Configuration Properties” from the menu. Select the Snsr 1 tab and apply damping requirements.

Apply changes made (see “Apply AMS Changes” on page 3-6).

2-Wire RTD Offset

Fast Key Sequence	1, 3, 2, 1, 2, 1
-------------------	------------------

The *2-Wire RTD Offset* command allows the user to input the measured lead wire resistance, which will result in the transmitter adjusting its temperature measurement to correct the error caused by this resistance. Due to a lack of lead wire compensation within the RTD, temperature measurement made with a 2-wire RTD are often inaccurate. See “Sensor Lead Wire Resistance Effect– RTD Input” on page 2-11 for more information.

To utilize this feature perform the following steps:

1. Measure the lead wire resistance of both RTD leads after installing the 2-wire RTD and the 644H.
2. From the HOME screen, select 1 *Device Setup*, 3 *Configuration*, 2 *Sensor Configuration*, 1 *Sensor 1*, 2 *Snsr 1 Setup*, and 1 *2-Wire Offset*.
3. Enter the total measured resistance of the two RTD leads at the *2-Wire Offset* prompt. Enter this resistance as a negative (–) value to ensure proper adjustment. The transmitter then adjusts its temperature measurement to correct the error caused by lead wire resistance.

AMS

Right click on the device and select “Configuration Properties” from the menu. Select the Snsr 1 tab to configure the 2 Wire Offset.

Apply changes made (see “Apply AMS Changes” on page 3-6).

Information Variables

Access the transmitter information variables on-line using the HART Communicator or other suitable communications device. The following is a list of transmitter information variables. These variables include device identifiers, factory-set configuration variables, and other information. A description of each variable, the corresponding fast key sequence, and a review of its purposes are provided.

Tag

Fast Key Sequence	1, 3, 4, 1
-------------------	------------

The *Tag* variable is the easiest way to identify and distinguish between transmitters in multi-transmitter environments. Use it to label transmitters electronically according to the requirements of the application. The tag defined is automatically displayed when a HART Communicator establishes contact with the transmitter at power-up. The tag may be up to eight characters long and has no impact on the primary variable readings of the transmitter.

Date

Fast Key Sequence	1, 3, 4, 2
-------------------	------------

The *Date* command is a user-defined variable that provides a place to save the date of the last revision of configuration information. It has no impact on the operation of the transmitter or the HART Communicator.

Descriptor

Fast Key Sequence	1, 3, 4, 3
-------------------	------------

The *Descriptor* variable provides a longer user-defined electronic label to assist with more specific transmitter identification than is available with the tag variable. The descriptor may be up to 16 characters long and has no impact on the operation of the transmitter or the HART Communicator.

Message

Fast Key Sequence	1, 3, 4, 4
-------------------	------------

The *Message* variable provides the most specific user-defined means for identifying individual transmitters in multi-transmitter environments. It allows for 32 characters of information and is stored with the other configuration data. The message variable has no impact on the operation of the transmitter or the HART Communicator.

AMS

Right click on the device and select “Configuration Properties” from the menu. Select the Device tab to enter alphanumeric device information.

Apply changes made (see “Apply AMS Changes” on page 3-6).

Diagnostics and Service

Test Device

Fast Key Sequence	1, 2, 1
-------------------	---------

The *Test Device* command initiates a more extensive diagnostics routine than that performed continuously by the transmitter. The *Test Device* menu lists the following options:

- *1 Loop test* verifies the output of the transmitter, the integrity of the loop, and the operations of any recorders or similar devices installed in the loop. See “Loop Test” below for more information.
- *2 Self Test* initiates a transmitter self test. Error codes are displayed if there is a problem.
- *3 Master Reset* sends out a command that restarts and tests the transmitter. A master reset is like briefly powering down the transmitter. Configuration data remains unchanged after a master reset.
- *4 Status* lists error codes. **ON** indicates a problem, and **OFF** means there are no problems.

Loop Test

Fast Key Sequence	1, 2, 1, 1
-------------------	------------

The *Loop Test* command verifies the output of the transmitter, the integrity of the loop, and the operations of any recorders or similar devices installed in the loop. To initiate a loop test, perform the following procedure:

1. Connect a reference meter to the transmitter. To do so, shunt the transmitter power through the meter at some point in the loop.
2. 644H: From the **HOME** screen, select *1 Device Setup, 2 Diag/Serv, 1 Test Device, 1 Loop Test* before performing a loop test.
644 rail mount, select *1 Device Setup, 2 Diagnostics and Service, 2 Loop Test*. Select **OK** after setting the control loop to manual. The communicator displays the loop test menu.
3. Select a discreet milliampere level for the transmitter to output. At the **CHOOSE ANALOG OUTPUT** prompt, select *1 4mA, 2 20mA*, or select *3 other* to manually input a value between 4 and 20 mA.
4. Check the current meter installed in the test loop to verify that it reads the value that was commanded to output. If the readings do not match, either the transmitter requires an output trim or the current meter is malfunctioning.

After completing the test procedure, the display returns to the loop test screen and another output value can be chosen.

AMS

Right click and select “Diagnostics and Test.” Select “Loop Test.” The *loop test wizard* will walk through the process to fix the output for the sensor.

The transmitter must be returned to normal conditions (turn off loop test) before placing back in process

Right click and select “Diagnostics and Test.” Select “Loop Test.” The *loop test wizard* will walk through the process to fix the analog output. From the *loop test wizard* screen choose “END.” A message will appear indicating that it is OK to return to normal.

Master Reset

Fast Key Sequence	1, 2, 1, 3
-------------------	------------

Master Reset resets the electronics without actually powering down the unit. It does not return the transmitter to the original factory configuration.

AMS

Right click on the device and select “Diagnostics and Test” from the menu. Choose “Master Reset.”

The *wizard* will perform the reset.

Active Calibrator

Fast Key Sequence	1, 2, 2, 1, 3
-------------------	---------------

The *Active Calibrator Mode* command enables or disables the pulsating current feature. The transmitter ordinarily operates with pulsating current so that sensor diagnostic functions, such as open sensor detection and EMF compensation, can be performed correctly. Some calibration equipment requires steady current to function properly. By enabling the Active Calibrator Mode the transmitter stops sending pulsating current to the sensor and supplies a steady current. Disabling the Active Calibrator returns the transmitter to its normal operating state of sending a pulsating current to the sensor, thus enabling the sensor diagnostic functions.

The Active Calibrator Mode is volatile and will be automatically disabled when power is cycled or when a Master Reset is performed using the HART Communicator.

NOTE

The Active Calibrator Mode must be disabled before returning the transmitter to the process. This will ensure that the full diagnostic capabilities of the 644 are available.

Disabling or enabling the Active Calibrator Mode will not change any of the sensor trim values stored in the transmitter.

Sensor Review

Fast Key Sequence	1, 4, 2
-------------------	---------

The *Signal Condition* command allows viewing or changing the primary variable lower and upper range values, sensor percent of range, and sensor damping.

AMS

Right click on the device and select “Configuration Properties” from the menu. Select the Snr 1 tab and review sensor configuration.

Apply changes made (see “Apply AMS Changes” on page 3-6).

Write Protect

Fast Key Sequence	1, 2, 3
-------------------	---------

The *Write Protect* command allows you to protect the transmitter configuration data from accidental or unwarranted changes. To enable the write protect feature, perform the following procedure:

1. From the **HOME** screen select *1 Device Setup, 2 Diag/Service, 3 Write Protect*.
2. Select *Enable WP*.

NOTE

To disable write protect on the 644, repeat the procedure, replacing *Enable WP* with *Disable WP*.

AMS

Right click on the device and select “Configuration Properties” from the menu. Select the Basic Setup tab and enable WP.

Apply changes made (see “Apply AMS Changes” on page 3-6).

HART Output

Fast Key Sequence	1, 3, 3, 3
-------------------	------------

The *HART Output* command allows the user to make changes to the multidrop address, specify the number of requested preambles, initiate burst mode, or make changes to the burst options.

AMS

Right click on the device and select “Configuration Properties” from the menu. Select the HART tab to configure HART multidrop addressing.

Apply changes made (see “Apply AMS Changes” on page 3-6).

Alarm and Saturation

Fast Key Sequence	1, 3, 3, 2
-------------------	------------

The *Alarm/Saturation* command allows the alarm settings (Hi or Low) and saturation values to be viewed and changed. To change the alarm values and saturation values, select the value to be changed, either *2 Low Alarm, 3 High Alarm, 4 Low Sat.*, or *5 High Sat*. Enter the desired new value, which must fall within the guidelines given below.

- The low alarm value must be between 3.30 and 3.75 mA
- The high alarm value must be between 21.0 and 23.0 mA
- The low saturation level must be between the low alarm value plus 0.1 mA and 3.9 mA.

Example: The low alarm value has been set to 3.7 mA. Therefore, the low saturation level, S, must be $3.8 \leq S \leq 3.9$ mA.

- The high saturation level must be between 20.5 mA and the high alarm value minus 0.1 mA.

Example: The high alarm value has been set to 20.8 mA. Therefore, the low saturation level, S, must be $20.5 \leq S \leq 20.7$ mA.

AMS

For AMS, configure the sensor as indicated above.

Right click on the device and select “Configuration Properties” from the menu. Select the Analog Output tab to define the alarm and saturation levels. From the Alarm box, enter the low and high alarm and the low and high saturation.

Apply changes made (see “Apply AMS Changes” on page 3-6).

Rerange

Reranging the transmitter sets the measurement range to the limits of expected readings. Setting the measurement range to the limits of expected readings maximizes transmitter performance; the transmitter is most accurate when operated within the expected temperature range for your application.

PV Range Values

Fast Key Sequence	1, 3, 3, 1
-------------------	------------

The *PV URV* and *PV LRV* commands, found in the *PV Range Values* menu screen, allow the user to set the transmitter’s lower and upper range values using limits of expected readings. The range of expected readings is defined by the Lower Range Value (LRV) and Upper Range Value (URV). The transmitter range values can be reset as often as necessary to reflect changing process conditions. From the *PV Range Values* screen select *1 PV LRV* to change the lower range value and *2 PV URV* to change the upper range value.

NOTE:

The rerange functions should not be confused with the trim functions. Although the rerange command matches a sensor input to a 4–20 mA output, as in conventional calibration, it does not affect the transmitter’s interpretation of the input.

AMS

Right click on the device and select “Configuration Properties” from the menu. Select the Basic Setup tab and set the URV and LRV.

Apply changes made (see “Apply AMS Changes” on page 3-6).

Intermittent Threshold

Fast Key Sequence	1, 3, 5, 4
-------------------	------------

The threshold value can be changed from the default value of 2%. Turning the Intermittent Sensor Detect feature **OFF** or leaving it **ON** and increasing the threshold value above the default does not affect the time needed for the transmitter to output the correct alarm signal after detecting a true open sensor condition. However, the transmitter may briefly output a false temperature reading for up to one update in either direction (see Figure 3-4 on page 3-18) up to the threshold value (100% of sensor limits if Intermittent Sensor Detect is **OFF**). Unless rapid response rate is necessary, the suggested setting of the Intermittent Sensor Detect mechanism is **ON** with 2% threshold.

Figure 3-3. Open Sensor Response

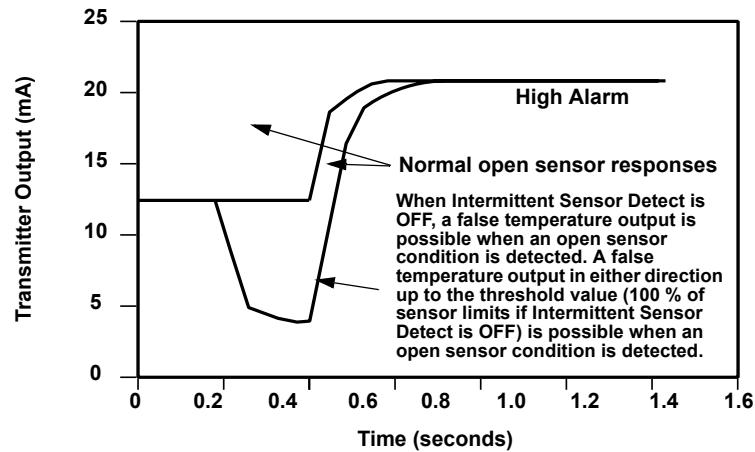

HART

644-644_03

Intermittent Sensor Detect (Advanced Feature)

The Intermittent Sensor Detect feature is designed to guard against process temperature readings caused by intermittent open sensor conditions (an *intermittent* sensor condition is an open sensor condition that lasts less than one update). By default, the transmitter is shipped with the Intermittent Sensor Detect feature switched **ON** and the threshold value set at 2% of sensor limits. The Intermittent Sensor Detect feature can be switched **ON** or **OFF** and the threshold value can be changed to any value between 0 and 100% of the sensor limits with a HART communicator.

Transmitter Behavior with Intermittent Sensor Detect ON

When the Intermittent Sensor Detect feature is switched **ON**, the transmitter can eliminate the output pulse caused by intermittent open sensor conditions. Process temperature changes (ΔT) within the threshold value will be tracked normally by the transmitter's output. A ΔT greater than the threshold value will activate the intermittent sensor algorithm. True open sensor conditions will cause the transmitter to go into alarm.

The threshold value of the 644 should be set at a level that allows the normal range of process temperature fluctuations; too high and the algorithm will not be able to filter out intermittent conditions; too low and the algorithm will be activated unnecessarily. The default threshold value is 2% of the sensor limits.

Transmitter Behavior with Intermittent Sensor Detect OFF

When the Intermittent Sensor Detect feature is switched **OFF**, the transmitter tracks all process temperature changes, even if they are the consequence of an intermittent sensor. (The transmitter in effect behaves as though the threshold value had been set at 100%.) The output delay due to the intermittent sensor algorithm will be eliminated.

AMS

Right click on the device and select "Configuration Properties" from the menu. Select the Electronics tab. From the Measurement Filtering Box, configure the Intermit threshold.

Apply changes made (see "Apply AMS Changes" on page 3-6).

Open Sensor Holdoff

Fast Key Sequence	1, 3, 5, 3
-------------------	------------

The *Open Sensor Holdoff* option, at the normal setting, enables the 644 to be more robust under heavy EMI conditions. This is accomplished through the software by having the transmitter perform additional verification of the open sensor status prior to activating the transmitter alarm. If the additional verification shows that the open sensor condition is not valid, the transmitter will not go into alarm.

For users of the 644 that desire a more vigorous open sensor detection, the Open Sensor Holdoff option can be changed to a fast setting. With this setting, the transmitter will report an open sensor condition without additional verification of the open condition.

AMS

Right click on the device and select “Configuration Properties” from the menu. Select the Electronics tab. From the Measurement Filtering Box box, configure the Open Snsr Holdoff.

Apply changes made (see “Apply AMS Changes” on page 3-6).

MULTIDROP COMMUNICATION

Multidropping refers to the connection of several transmitters to a single communications transmission line. Communication between the host and the transmitters takes place digitally with the analog output of the transmitters deactivated.

Many Rosemount transmitters can be multidropped. With the HART communications protocol, up to 15 transmitters can be connected on a single twisted pair of wires or over leased phone lines.

A HART Communicator can test, configure, and format a multidropped 644 transmitter in the same way as in a standard point-to-point installation.

The application of a multidrop installation requires consideration of the update rate necessary from each transmitter, the combination of transmitter models, and the length of the transmission line. Each transmitter is identified by a unique address (1–15) and responds to the commands defined in the HART protocol.

Figure 3-4. Typical Multidropped Network

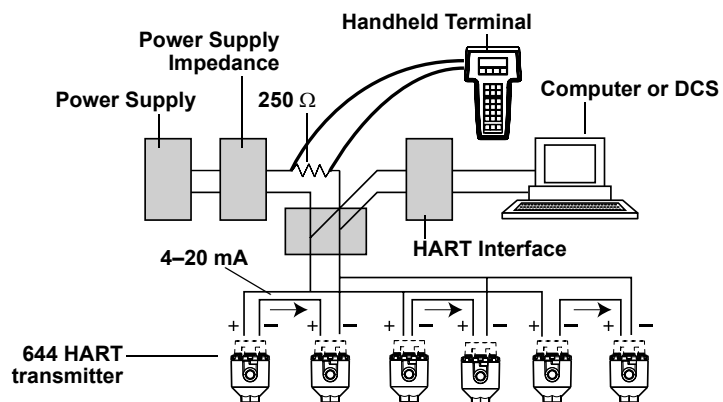

Figure 3-4 shows a typical multidrop network. Do not use this figure as an installation diagram. Contact Emerson Process Management product support with specific requirements for multidrop applications.

NOTE

644 transmitters are set to address 0 at the factory, allowing them to operate in the standard point-to-point manner with a 4–20 mA output signal. To activate multidrop communication, the transmitter address must be changed to a number between 1 and 15. This change deactivates the 4–20 mA analog output, sending it to 4 mA. The failure mode current also is disabled.

AMS

Right click and select “Configuration Properties” from the menu screen. Select the “HART” tab. From here, assign the polling address.

OPERATION AND MAINTENANCE

Calibration

Calibrating the transmitter increases the measurement precision by allowing corrections to be made to the factory-stored characterization curve by digitally altering the transmitter’s interpretation of the sensor input.

To understand calibration, it is necessary to understand that smart transmitters operate differently from analog transmitters. An important difference is that smart transmitters are factory-characterized, meaning that they are shipped with a standard sensor curve stored in the transmitter firmware. In operation, the transmitter uses this information to produce a process variable output, in engineering units, dependent on the sensor input.

Calibration of the 644 may include the following procedures:

- Sensor Input Trim: digitally alter the transmitter’s interpretation of the input signal
- Transmitter Sensor Matching: generates a special custom curve to match that specific sensor curve, as derived from the Callendar-Van Dusen constants
- Output Trim: calibrates the transmitter to a 4–20 mA reference scale
- Scaled Output Trim: calibrates the transmitter to a user-selectable reference scale.

Trim the Transmitter

One or more of the trim functions may be used when calibrating. The trim functions are as follows

- Sensor Input Trim
- Transmitter Sensor Matching
- Output Trim
- Output Scaled Trim

Sensor Input Trim

Fast Key Sequence	1, 2, 2, 1, 1
-------------------	---------------

Perform a sensor trim if the transmitters digital value for the primary variable does not match the plant's standard calibration equipment. The sensor trim function calibrates the sensor to the transmitter in temperature units or raw units. Unless your site-standard input source is NIST-traceable, the trim functions will not maintain the NIST-traceability of the system.

The *Sensor Input Trim* command allows the transmitter's interpretation of the input signal to be digitally altered (see Figure 3-5). The sensor reference command trims, in engineering (F, °C, °R, K) or raw (Ω , mV) units, the combined sensor and transmitter system to a site standard using a known temperature source. Sensor trimming is suitable for validation procedures or for applications that require calibrating the sensor and transmitter together.

Use the following procedure to perform a sensor trim with a 644H.

1. Connect the calibration device or sensor to the transmitter. Refer to Figure 2-9 on page 2-11 or inside of the transmitter terminal side cover for sensor wiring diagrams. (If using an active calibrator, please see "Active Calibrator" on page 3-14)
2. Connect the communicator to the transmitter loop.
3. From the Home screen, select *1 Device Setup, 2 Diag/Service, 2 Calibration, 1 Sensor 1 Trim, 1 Sensor 1 Input Trim* to prepare to trim the sensor.
4. Set the control loop to manual and select **OK**.
5. Select the appropriate sensor trim units at the **ENTER SNSR 1 TRIM UNITS** prompt.
6. Select *1 Lower Only* or *2 Lower and Upper* at the **SELECT SENSOR TRIM POINTS** prompt.
7. Adjust the calibration device to the desired trim value (must be within the selected sensor limits). If a combined sensor and transmitter system are being trimmed, expose the sensor to a known temperature and allow the temperature reading to stabilize. Use a bath, furnace or isothermal block, measured with a site-standard thermometer, as the known temperature source.
8. Select **OK** once the temperature stabilizes. The communicator displays the output value the transmitter associates with the input value provided by the calibration device.
9. Enter the lower or upper trim point, depending on the selection in Step 6.

AMS

For AMS, configure the sensor as indicated above.

Right click on the device and select "Calibrate" from the menu. Select "Sensor 1 Trim," then "Sensor Input Trim."

The *wizard* will continue through the process.

The transmitter may be restored to the factory default by selecting: "Calibration," "Sensor 1 Trim," "Revert to Factory Trim."

The *wizard* will recall the factory trim for a given sensor
 Apply changes made (see “AMS” on page 3-5).

Transmitter-Sensor Matching

Perform the *Transmitter Sensor Matching* procedure to enhance the temperature measurement accuracy of the system (see the comparison below) and if you have a sensor with Callendar-Van Dusen constants. When ordered from Emerson Process Management, sensors with Callendar-Van Dusen constants are NIST-traceable.

The 644 accepts Callendar-Van Dusen constants from a calibrated RTD schedule and generates the actual curve to match that specific sensor curve.

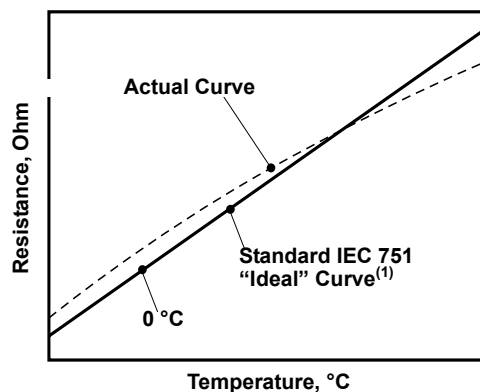

(1) The Actual Curve is identified from the Callendar-Van Dusen equation.

System Accuracy Comparison at 150 °C Using a PT 100 ($\alpha=0.00385$) RTD with a Span of 0 to 200 °C

Standard RTD		Matched RTD	
644H	±0.15 °C	644H	±0.15 °C
Standard RTD	±1.05 °C	Matched RTD	±0.18 °C
Total System ⁽¹⁾	±1.06 °C	Total System ⁽¹⁾	±0.23 °C

(1) Calculated using root-summed-squared (RSS) statistical method

$$\text{TotalSystemAccuracy} = \sqrt{(\text{TransmitterAccuracy})^2 + (\text{SensorAccuracy})^2}$$

Callendar-Van Dusen equation:

$$R_t = R_0 + R_0\alpha [t - \delta(0.01t-1)(0.01t) - \beta(0.01t - 1)(0.01t)^3]$$

The following input variables, included with specially-ordered Rosemount temperature sensors, are required:

- R₀ = Resistance at Ice Point
- Alpha = Sensor Specific Constant
- Beta = Sensor Specific Constant
- Delta = Sensor Specific Constant

To input Callendar-Van Dusen constants, perform the following procedure:

1. From the **HOME** screen, select *1 Device Setup, 3 Configuration, 2 Sensor Config, 1 Chng Type/Conn, 1 Sensor 1* or *2 Sensor 2*. Set the control loop to manual and select **OK**.
 2. Select *Cal VanDusen* at the **ENTER SENSOR TYPE** prompt.
 3. Select the appropriate number of wires at the **ENTER SENSOR CONNECTION** prompt.
 4. Enter the R_o , Alpha, Delta, and Beta values from the stainless steel tag attached to the special-order sensor when prompted.
 5. Return the control loop to automatic control and select **OK**.
- To disable the transmitter-sensor matching feature from the **HOME** screen select *1 Device Setup, 3 Configuration, 2 Sensor Config, 1 Chng Type/Conn, 1 Sensor 1* or *2 Sensor 2*. Choose the appropriate sensor type from the **ENTER SENSOR TYPE** prompt.

NOTE

When the transmitter-sensor matching is disabled, the transmitter reverts to either user or factory trim, whichever was used previously. Make certain the transmitter engineering units default correctly before placing the transmitter into service.

AMS

Right click on the device and select "Sensor Connections" from the menu. Select the "Sensor 1 Config." Select "Sensor Connections."

The *wizard* will go through the required changes.

NOTE

Under "Enter Sensor Type" select "Cal VanDusen."

Output Trim or Scaled Output Trim

Perform an output trim or a scaled output trim if the digital value for the primary variable matches the plant's standards but the transmitter's analog output does not match the reading on the output device. The output trim function calibrates the transmitter to a 4–20 mA reference scale; the scaled output trim function calibrates to a user-selectable reference scale. To determine the need for an output trim or a scaled output trim, perform a loop test (see "Loop Test" on page 3-13).

Figure 3-5. Dynamics of Smart Temperature Measurement

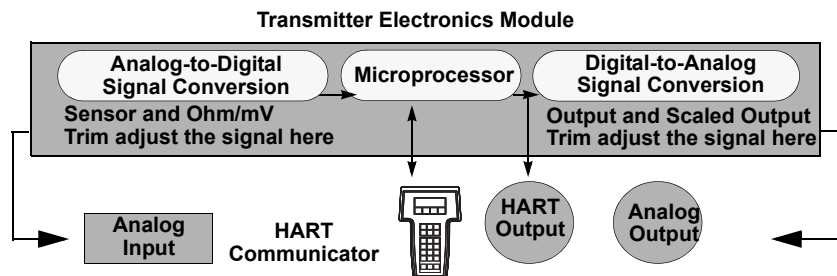

Output Trim

Fast Key Sequence	1, 2, 2, 2
-------------------	------------

The *D/A Trim* command allows the transmitter's conversion of the input signal to a 4–20 mA output to be altered (see Figure 3-5 on page 3-22). Adjust the analog output signal at regular intervals to maintain measurement precision. To perform a digital-to-analog trim, perform the following procedure:

1. From the **HOME** screen, select *1 Device setup, 2 Diag/Service, 2 Calibration, 2 D/A trim*. Set the control loop to manual and select **OK**.
2. Connect an accurate reference meter to the transmitter at the **CONNECT REFERENCE METER** prompt. To do so, shunt the power to the transmitter through the reference meter at some point in the loop. Select **OK** after connecting the reference meter.
3. Select **OK** at the **SETTING FLD DEV OUTPUT TO 4 MA** prompt. The transmitter outputs 4.00 mA.
4. Record the actual value from the reference meter, and enter it at the **ENTER METER VALUE** prompt. The communicator prompts the user to verify whether or not the output value equals the value on the reference meter.
5. If the reference meter value equals the transmitter output value, then select *1 Yes* and go to step 6. If the reference meter value does not equal the transmitter output value, then select *2 No* and go to step 4.
6. Select **OK** at the **SETTING FLD DEV OUTPUT TO 20 MA** prompt and repeat steps 4 and 5 until the reference meter value equals the transmitter output value.
7. Return the control loop to automatic control and select **OK**.

AMS

Right click on the device and select "Calibrate" from the menu. Select "D/A Trim."

This *wizard* will go through the required changes.

Scaled Output Trim

Fast Key Sequence	1, 2, 2, 3
-------------------	------------

The *Scaled D/A Trim* command matches the 4 and 20 mA points to a user-selectable reference scale other than 4 and 20 mA (2–10 volts, for example). To perform a scaled D/A trim, connect an accurate reference meter to the transmitter and trim the output signal to scale as outlined in the "Output Trim" procedure.

AMS

Right click on the device and select "Calibrate" from the menu. Select "Scaled D/A Trim."

This *wizard* will go through the required changes.

Rosemount 644

HART

Hardware

Maintenance

The 644H has no moving parts and requires minimal scheduled maintenance.

Sensor Checkout



To determine whether the sensor is at fault, replace it with another sensor or connect a test sensor locally at the transmitter to test remote sensor wiring. Select any standard, off-the-shelf sensor for use with a 644, or consult the factory for a replacement special sensor and transmitter combination.

Diagnostic Messages

Hardware



If a malfunction is suspected despite the absence of diagnostics messages on the HART Communicator or AMS display, follow the procedures described in Table 3-2 to verify that transmitter hardware and process connections are in good working order. Under each of four major symptoms, specific suggestions are offered for solving the problem.

Table 3-2. 644H Troubleshooting Chart

Symptom	Potential Source	Corrective Action
Transmitter Does Not Communicate with HART Communicator	Loop Wiring	<ul style="list-style-type: none"> Check the revision level of the transmitter device descriptors (DDs) stored in the communicator. The communicator should report Dev v6, DD v1. Check for a minimum of 250 ohms resistance between the power supply and HART Communicator connection. Check for adequate voltage to the transmitter. If a HART Communicator is connected and 250 ohms resistance is in the loop, the transmitter requires a minimum of 12.0 V at the terminals to operate (over entire 3.75 to 23 mA operating range). Check for intermittent shorts, open circuits, and multiple grounds. Specify the transmitter by tag number. For certain non-standard transmitter installations, it may be necessary, because of excessive line length, to specify the transmitter tag number to initiate communications.
High Output	Sensor Input Failure or Connection Loop Wiring Power Supply Electronics Module	<ul style="list-style-type: none"> Connect a HART Communicator and enter the transmitter test mode to isolate a sensor failure. Check for a sensor open or short circuit. Check the process variable to see if it is out of range. Check for dirty or defective terminals, interconnecting pins, or receptacles. Check the output voltage of the power supply at the transmitter terminals. It should be 12.0 to 42.4 V dc (over entire 3.75 to 23 mA operating range). Connect a HART Communicator and enter the transmitter status mode to isolate module failure. Connect a HART Communicator and check the sensor limits to ensure calibration adjustments are within the sensor range.
Erratic Output	Loop Wiring Electronics Module	<ul style="list-style-type: none"> Check for adequate voltage to the transmitter. It should be 12.0 to 42.4 V dc at the transmitter terminals (over entire 3.75 to 23 mA operating range). Check for intermittent shorts, open circuits, and multiple grounds. Connect a HART Communicator and enter the Loop test mode to generate signals of 4 mA, 20 mA, and user-selected values. Connect a HART Communicator and enter the transmitter test mode to isolate module failure.

Symptom	Potential Source	Corrective Action
Low Output or No Output	Sensor Element	<ul style="list-style-type: none"> • Connect a HART Communicator and enter the Transmitter test mode to isolate a sensor failure. • Check the process variable to see if it is out of range.
	Loop Wiring	<ul style="list-style-type: none"> • Check for adequate voltage to the transmitter. It should be 12.0 to 42.4 V dc (over entire 3.75 to 23 mA operating range). • Check for shorts and multiple grounds. • Check for proper polarity at the signal terminal. • Check the loop impedance. • Connect a HART Communicator and enter the Loop test mode. • Check wire insulation to detect possible shorts to ground.
	Electronics Module	<ul style="list-style-type: none"> • Connect a HART Communicator and check the sensor limits to ensure calibration adjustments are within the sensor range. • Connect a HART Communicator and enter the Transmitter test mode to isolate an electronics module failure.

HART

HART Communicator

Table 3-3 provides a guide to diagnostic messages used by the HART Communicator.

Variable parameters within the text of a message are indicated with the notation *<variable parameter>*. Reference to the name of another message is identified by the notation *[another message]*.

Table 3-3. HART Diagnostics Messages

Message	Description
Add item for ALL device types or only for this ONE device type	Asks the user whether the hot key item being added should be added for all device types or only for the type of device that is connected.
Command Not Implemented	The connected device does not support this function.
Communication Error	Either a device sends back a response indicating that the message it received was unintelligible, or the HART Communicator cannot understand the response from the device.
Configuration memory not compatible with connected device	The configuration stored in memory is incompatible with the device to which a transfer has been requested.
Device Busy	The connected device is busy performing another task.
Device Disconnected	Device fails to respond to a command.
Device write protected	Device is in write-protect mode. Data can not be written.
Device write protected. Do you still want to shut off?	Device is in write-protect mode. Press YES to turn the HART Communicator off and lose the unsent data.
Display value of variable on hotkey menu?	Asks whether the value of the variable should be displayed adjacent to its label on the hotkey menu if the item being added to the hotkey menu is a variable.
Download data from configuration memory to device	Prompts user to press SEND softkey to initiate a memory to device transfer.
Exceed field width	Indicates that the field width for the current arithmetic variable exceeds the device- specified description edit format.
Exceed precision	Indicates that the precision for the current arithmetic variable exceeds the device- specified description edit format.
Ignore next 50 occurrences of status?	Asked after displaying device status. Softkey answer determines whether next 50 occurrences of device status will be ignored or displayed.
Illegal character	An invalid character for the variable type was entered.
Illegal date	The day portion of the date is invalid.
Illegal month	The month portion of the date is invalid.
Illegal year	The year portion of the date is invalid.
Incomplete exponent	The exponent of a scientific notation floating point variable is incomplete.
Incomplete field	The value entered is not complete for the variable type.
Looking for a device	Polling for multidropped devices at addresses 1–15.
Mark as read only variable on hotkey menu?	Asks whether the user should be allowed to edit the variable from the hotkey menu if the item being added to the hotkey menu is a variable.
No device configuration in configuration memory	There is no configuration saved in memory available to re-configure off-line or transfer to a device.
No Device Found	Poll of address zero fails to find a device, or poll of all addresses fails to find a device if auto-poll is enabled.
No hotkey menu available for this device.	There is no menu named “hotkey” defined in the device description for this device.
No offline devices available.	There are no device descriptions available to be used to configure a device offline.
No simulation devices available.	There are no device descriptions available to simulate a device.
No UPLOAD_VARIABLES in ddl for this device	There is no menu named “upload_variables” defined in the device description for this device. This menu is required for offline configuration.
No Valid Items	The selected menu or edit display contains no valid items.
OFF KEY DISABLED	Appears when the user attempts to turn the HART Communicator off before sending modified data or before completing a method.
Online device disconnected with unsent data. RETRY or OK to lose data.	There is unsent data for a previously connected device. Press RETRY to send data, or press OK to disconnect and lose unsent data.

Message	Description
Out of memory for hotkey configuration. Delete unnecessary items.	There is no more memory available to store additional hotkey items. Unnecessary items should be deleted to make space available.
Overwrite existing configuration memory	Requests permission to overwrite existing configuration either by a device-to-memory transfer or by an offline configuration. User answers using the softkeys.
Press OK.	Press the OK softkey. This message usually appears after an error message from the application or as a result of HART communications.
Restore device value?	The edited value that was sent to a device was not properly implemented. Restoring the device value returns the variable to its original value.
Save data from device to configuration memory	Prompts user to press SAVE softkey to initiate a device-to-memory transfer.
Saving data to configuration memory.	Data is being transferred from a device to configuration memory.
Sending data to device.	Data is being transferred from configuration memory to a device.
There are write only variables which have not been edited. Please edit them.	There are write-only variables which have not been set by the user. These variables should be set or invalid values may be sent to the device.
There is unsent data. Send it before shutting off?	Press YES to send unsent data and turn the HART Communicator off. Press NO to turn the HART Communicator off and lose the unsent data.
Too few data bytes received	Command returns fewer data bytes than expected as determined by the device description.
Transmitter Fault	Device returns a command response indicating a fault with the connected device.
Units for <variable label> has changed. Unit must be sent before editing, or invalid data will be sent.	The engineering units for this variable have been edited. Send engineering units to the device before editing this variable.
Unsent data to online device. SEND or LOSE data	There is unsent data for a previously connected device which must be sent or thrown away before connecting to another device.
Use up/down arrows to change contrast. Press DONE when done.	Gives direction to change the contrast of the HART Communicator display.
Value out of range	The user-entered value is either not within the range for the given type and size of variable or not within the min/max specified by the device.
<message> occurred reading/writing <variable label>	Either a read/write command indicates too few data bytes received, transmitter fault, invalid response code, invalid response command, invalid reply data field, or failed pre- or post-read method; or a response code of any class other than SUCCESS is returned reading a particular variable.
<variable label> has an unknown value. Unit must be sent before editing, or invalid data will be sent.	A variable related to this variable has been edited. Send related variable to the device before editing this variable.

AMS Software

The following is a list of messages used by AMS software. These are communicated through pop-up menus.

Message	Description
Command not implemented	The connected device does not support this function.
Communication error	Either a device sends back a response indicating that the message it received was unintelligible, or the HART Communicator cannot understand the response from the device.
Device busy	The connected device is busy performing another task.
Device disappears from list	Device fails to respond to a command.
Device write protected	Device is in write-protect mode. Data can not be written.
Illegal character	An invalid character for the variable type was entered.
Illegal date	The day portion of the date is invalid.
Illegal month	The month portion of the date is invalid.
Illegal year	The year portion of the date is invalid.
Incomplete exponent	The exponent of a scientific notation floating point variable is incomplete.
Incomplete field	The value entered is not complete for the variable type.
Sending data to device	Data is being transferred from configuration memory to a device.
There are write only variables which have not been edited. Please edit them	There are write-only variables that have not been set by the user. These variables should be set or invalid values may be sent to the device.
There is unsent data. Send it before shutting off?	Press YES to send unsent data and turn the HART Communicator off. Press NO to turn the HART Communicator off and lose the unsent data.
Too few data bytes received	Command returns fewer data bytes than expected as determined by the device description.
Transmitter fault	Device returns a command response indicating a fault with the connected device.
Units for <variable label> has changed. Unit must be sent before editing, or invalid data will be sent.	The engineering units for this variable have been edited. Send engineering units to the device before editing this variable.
Unsent data to online device. SEND or LOSE data	There is unsent data for a previously connected device which must be sent or thrown away before connecting to another device.
Value out of range	The user-entered value is either not within the range for the given type and size of variable or not within the min/max specified by the device.
<message> occurred reading/writing <variable label>	Either a read/write command indicates too few data bytes received, transmitter fault, invalid response code, invalid response command, invalid reply data field, or failed pre- or post-read method; or a response code of any class other than SUCCESS is returned reading a particular variable.
<variable label> has an unknown value. Unit must be sent before editing, or invalid data will be sent.	A variable related to this variable has been edited. Send related variable to the device before editing this variable.

LCD Display

The LCD display displays abbreviated diagnostic messages for troubleshooting the transmitter. To determine the cause of a message, use a HART Communicator to further interrogate the transmitter. A description of each diagnostic message is identified in Table 3-4. The device sometimes requires additional interrogation to determine the source of the warning. Contact Emerson Process Management Customer Central at (800) 999-9307 for further information.

Table 3-4. LCD Display Diagnostics

ALARM	Description
DEV FAIL	<p>The top line of the display scrolls through the following three messages:</p> <ul style="list-style-type: none"> • "BAD" • "DEV" • "FAIL" <p>This message indicates one of several conditions. For example, the transmitter may have experienced an electronics failure while attempting to store information. If diagnostics indicate an electronics failure, replace the transmitter with a new one. Contact the nearest Emerson Process Management Field Service Center if necessary.</p>
SNSR FAIL	<p>The top line of the display scrolls through the following three messages:</p> <ul style="list-style-type: none"> • "BAD" • "SNSR" • "FAIL" <p>The bottom line display s the name of the sensor that has failed. This message indicates that the transmitter has detected an open or shorted sensor condition. The sensor may be disconnected, connected improperly, or malfunctioning. Check the sensor connections and sensor continuity.</p>
UNCRN	<p>The top line of the display alternates between "UNCRN" and the sensor value. The bottom line will display the name of the sensor for which this message applies. The uncertain message is displayed when the sensor reading is outside of the acceptable temperature range for the particular sensor type.</p>
FIXED	<p>During a loop test or a a 4–20 mA output trim, the analog output defaults to a fixed value. The top line of the display alternates between "FIXED" and the amount of current selected in milliamperes. The bottom line will hold on "AO mA."</p>
OFLOW	<p>The location of the decimal point, as configured in the meter setup, is not compatible wit the value to be displayed by the meter. For example, if the meter is measuring a process temperature greater than 9.9999 degrees and the meter decimal point is set to 4-digit precision, the meter will display an "OFLOW" message because it is only capable of displaying a maximum of 9.9999 when set to 4-digit precision.</p>
ALARM	<p>When a failure occurs and the meter is configured to display Primary Variable Percent of Range and/or Analog Output, the top line o the meter will display "ALARM." This indicates that the transmitter is in failure mode.</p>
SAT	<p>When the transmitter output saturates and the meter is configured to display Primary Variable Percent of Range and/or Analog Output, the top line of the meter will display "SAT." This indicates that the transmitter output has reached saturation level.</p>

Rosemount 644

HART

Section 4 FOUNDATION Fieldbus Configuration

Overview	page 4-1
Safety Messages	page 4-1
General Block Information	page 4-2
Foundation fieldbus function blocks	page 4-4
Operation and Maintenance	page 4-14

OVERVIEW

This section provides information on configuring, troubleshooting, operating, and maintaining the Rosemount 644 Temperature transmitter using FOUNDATION fieldbus protocol.

SAFETY MESSAGES

Instructions and procedures in this section may require special precautions to ensure the safety of the personnel performing the operations. Information that potentially raises safety issues is indicated by a warning symbol (⚠). Please refer to the following safety messages before performing an operation preceded by this symbol.

Warnings

⚠ WARNING

Failure to follow these installation guidelines could result in death or serious injury.

- Make sure only qualified personnel perform the installation.

Explosions could result in death or serious injury.

- Do not remove the connection head cover in explosive atmospheres when the circuit is live.
- Before powering a FOUNDATION fieldbus segment in an explosive atmosphere, make sure the instruments in the loop are installed in accordance with intrinsically safe or non-incendive field wiring practices.
- Verify that the operating atmosphere of the transmitter is consistent with the appropriate hazardous locations certifications.
- All connection head covers must be fully engaged to meet explosion-proof requirements.

Process leaks could result in death or serious injury.

- Do not remove the thermowell while in operation.
- Install and tighten thermowells and sensors before applying pressure

Electrical shock could cause death or serious injury.

- Use extreme caution when making contact with the leads and terminals.

Rosemount 644

GENERAL BLOCK INFORMATION

Device Description

Before configuring the device, ensure the host has the appropriate Device Description file revision for this device. The device descriptor can be found on www.rosemount.com. The initial release of the Rosemount 644 with FOUNDATION fieldbus protocol is device revision 1.

Node Address

The transmitter is shipped at a temporary (248) address. This will enable FOUNDATION fieldbus host systems to automatically recognize the device and move it to a permanent address.

Modes

The Resource, Transducer, and all function blocks in the device have modes of operation. These modes govern the operation of the block. Every block supports both automatic (AUTO) and out of service (OOS) modes. Other modes may also be supported.

Changing Modes

To change the operating mode, set the `MODE_BLK.TARGET` to the desired mode. After a short delay, the parameter `MODE_BLOCK.ACTUAL` should reflect the mode change if the block is operating properly.

Permitted Modes

It is possible to prevent unauthorized changes to the operating mode of a block. To do this, configure `MODE_BLOCK.PERMITTED` to allow only the desired operating modes. It is recommended to always select OOS as one of the permitted modes.

Types of Modes

For the procedures described in this manual, it will be helpful to understand the following modes:

AUTO

The functions performed by the block will execute. If the block has any outputs, these will continue to update. This is typically the normal operating mode.

Out of Service (OOS)

The functions performed by the block will not execute. If the block has any outputs, these will typically not update and the status of any values passed to downstream blocks will be "BAD". To make some changes to the configuration of the block, change the mode of the block to OOS. When the changes are complete, change the mode back to AUTO.

MAN

In this mode, variables that are passed out of the block can be manually set for testing or override purposes.

Other Types of Modes

Other types of modes are Cas, RCas, ROut, IMan and LO. Some of these may be supported by different function blocks in the 644. For more information, see the Function Block manual (document number 00809-0100-4783).

NOTE

When an upstream block is set to OOS, this will impact the output status of all downstream blocks. The figure below depicts the hierarchy of blocks:

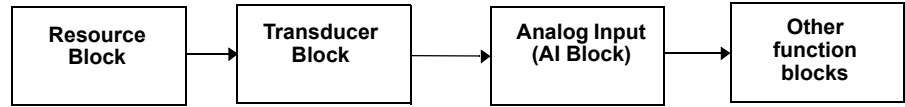

Link Active Scheduler

The 644 can be designated to act as the backup Link Active Scheduler (LAS) in the event that the designated LAS is disconnected from the segment. As the backup LAS, the 644 will take over the management of communications until the host is restored.

The host system may provide a configuration tool specifically designed to designate a particular device as a backup LAS. Otherwise, this can be configured manually as follows:

- ⚠ 1. Access the Management Information Base (MIB) for the 644. To activate the LAS capability, write 0x02 to the BOOT_OPERAT_FUNCTIONAL_CLASS object (Index 605). To deactivate, write 0x01.
- 2. Restart the device.

Block Installation

Rosemount devices are pre-configured with function blocks at the factory, the default permanent configuration for the 644 is listed below. The 644 can have up to ten additional instantiated function blocks.

- 2 Analog Input Blocks (tag names AI 1300, AI 1400)
- 1 Proportional/Integral/Derivative Block (tag name PID 1500)

The 644 supports the use of Function Block Instantiation. When a device supports block instantiation, the number of blocks and block types can be defined to match specific application needs. The number of blocks that can be instantiated is only limited by the amount of memory within the device and the block types that are supported by the device. Instantiation does not apply to standard device blocks like the Resource, Sensor Transducer, LCD Transducer, and Advanced Diagnostics Blocks.

By reading the parameter "FREE_SPACE" in the Resource block you can determine how many blocks you can instantiate. Each block that you instantiate takes up 4.5% of the "FREE_SPACE".

Block instantiation is done by the host control system or configuration tool, but not all hosts are required to implement this functionality. Please refer to your specific host or configuration tool manual for more information.

Capabilities

Virtual Communication Relationship (VCRs)

There are a total of 12 VCRs. One is permanent and 11 are fully configurable by the host system. Sixteen link objects are available.

Network Parameter	Value
Slot Time	8
Maximum Response Delay	2
Maximum Inactivity to Claim LAS Delay	32
Minimum Inter DLPDU Delay	8
Time Sync class	4 (1ms)
Maximum Scheduling Overhead	21
Per CLPDU PhL Overhead	4
Maximum Inter-channel Signal Skew	0
Required Number of Post-transmission-gab-ext Units	0
Required Number of Preamble-extension Units	1

Block Execution times

Analog Input = 45 ms
PID = 60 ms

FOUNDATION FIELDBUS FUNCTION BLOCKS

For reference information on the Resource, Sensor Transducer, AI, LCD Transducer blocks refer to "Foundation Fieldbus Block Information" on page A-1. Reference information on the PID block can be found in the Function Block manual document number 00809-0100-4783.

Resource Block (index number 1000)

The Resource Function Block (RB) contains diagnostic, hardware and electronics information. There are no linkable inputs or outputs to the Resource Block.

Sensor Transducer Block (index number 1100)

The Sensor Transducer Function Block (STB) temperature measurement data, including sensor and terminal temperature, The STB also includes information about sensor type, engineering units, linearization, reranging, damping, temperature compensation, and diagnostics.

LCD Transducer Block (index number 1200)

The LCD Transducer Block is used to configure the LCD meter.

Analog Input Block (index number 1300 and 1400)

The Analog Input Function Block (AI) processes the measurements from the sensor and makes them available to other function blocks. The output value from the AI block is in engineering units and contains a status indicating the quality of the measurement. The AI block is widely used for scaling functionality.

PID Block (index number 1500)

The PID Function Block combines all of the necessary logic to perform proportional/integral/derivative (PID) control. The block supports mode control, signal scaling and limiting, feed forward control, override tracking, alarm limit detection, and signal status propagation.

The block supports two forms of the PID equation: Standard and Series. You can choose the appropriate equation using the MATHFORM parameter. The Standard ISA PID equation is the default selection.

Resource Block

FEATURES and FEATURES_SEL

The parameters FEATURES and FEATURE_SEL determine optional behavior of the 644.

FEATURES

The FEATURES parameter is read only and defines which features are supported by the 644. Below is a list of the FEATURES the 644 supports.

UNICODE

All configurable string variables in the 644, except tag names, are octet strings. Either ASCII or Unicode may be used. If the configuration device is generating Unicode octet strings, you must set the Unicode option bit.

REPORTS

The 644 supports alert reports. The Reports option bit must be set in the features bit string to use this feature. If it is not set, the host must poll for alerts.

SOFTWARE LOCK

Inputs to the security and write lock functions include the software write lock bits of the FEATURE_SEL parameter, the WRITE_LOCK parameter, and the DEFINE_WRITE_LOCK parameter.

The WRITE_LOCK parameter prevents modification of parameters within the device except to clear the WRITE_LOCK parameter. During this time, the block will function normally updating inputs and outputs and executing algorithms. When the WRITE_LOCK condition is cleared, a WRITE_ALM alert is generated with a priority that corresponds to the WRITE_PRI parameter.

The FEATURE_SEL parameter enables the user to select the software write lock or no write lock capability. In order to enable the software write lock, the SOFT_W_LOCK bit must be set in the FEATURE_SEL parameter. Once this bit is set, the WRITE_LOCK parameter may be set to "Locked" or "Unlocked." Once the WRITE_LOCK parameter is set to "Locked" by the software, all user requested writes as determined by the DEFINE_WRITE_LOCK parameter shall be rejected.

The DEFINE_WRITE_LOCK parameter allows the user to configure whether the write lock function will control writing to all blocks, or only to the resource and transducer blocks. Internally updated data such as process variables and diagnostics will not be restricted.

N/A = No blocks are blocked

Physical = Locks resource and transducer block

Everything = Locks every block.

The following table displays all possible configurations of the WRITE_LOCK parameter.

FEATURE_SEL SW_SEL bit	WRITE_LOCK	WRITE_LOCK Read/Write	DEFINE_WRITE_LOCK	Write access to blocks
0 (off)	1 (unlocked)	Read only	NA	All
1 (on)	1 (unlocked)	Read/Write	NA	All
1 (on)	2 (locked)	Read/Write	Physical	Function Blocks only
1 (on)	2 (locked)	Read/Write	Everything	None

FEATURES_SEL

FEATURES_SEL is used to turn on any of the supported features. The default setting of the 644 does not select any of these features. Choose one of the supported features if any.

MAX_NOTIFY

The MAX_NOTIFY parameter value is the maximum number of alert reports that the resource can have sent without getting a confirmation, corresponding to the amount of buffer space available for alert messages. The number can be set lower, to control alert flooding, by adjusting the LIM_NOTIFY parameter value. If LIM_NOTIFY is set to zero, then no alerts are reported.

PlantWeb™ Alerts

The alerts and recommended actions should be used in conjunction with “Operation and Maintenance” on page 4-14.

The Resource Block will act as a coordinator for PlantWeb alerts. There will be three alarm parameters (FAILED_ALARM, MAINT_ALARM, and ADVISE_ALARM) which will contain information regarding some of the device errors which are detected by the transmitter software. There will be a RECOMMENDED_ACTION parameter which will be used to display the recommended action text for the highest priority alarm and a HEALTH_INDEX parameters (0 - 100) indicating the overall health of the transmitter. FAILED_ALARM will have the highest priority followed by MAINT_ALARM and ADVISE_ALARM will be the lowest priority.

FAILED_ALARMS

A failure alarm indicates a failure within a device that will make the device or some part of the device non-operational. This implies that the device is in need of repair and must be fixed immediately. There are five parameters associated with FAILED_ALARMS specifically, they are described below.

FAILED_ENABLED

This parameter contains a list of failures in the device which makes the device non-operational that will cause an alert to be sent. Below is a list of the failures with the highest priority first.

1. Electronics
2. NV Memory
3. HW / SW Incompatible
4. Primary Value
5. Secondary Value

FAILED_MASK

This parameter will mask any of the failed conditions listed in FAILED_ENABLED. A bit on means that the condition is masked out from alarming and will not be reported.

FAILED_PRI

Designates the alerting priority of the FAILED_ALM, see “Alarm Priority” on page 4-12. The default is 0 and the recommended value are between 8 and 15.

FAILED_ACTIVE

This parameter displays which of the alarms is active. Only the alarm with the highest priority will be displayed. This priority is not the same as the FAILED_PRI parameter described above. This priority is hard coded within the device and is not user configurable.

FAILED_ALM

Alarm indicating a failure within a device which makes the device non-operational.

MAINT_ALARMS

A maintenance alarm indicates the device or some part of the device needs maintenance soon. If the condition is ignored, the device will eventually fail. There are five parameters associated with MAINT_ALARMS, they are described below.

MAINT_ENABLED

The MAINT_ENABLED parameter contains a list of conditions indicating the device or some part of the device needs maintenance soon.

Below is a list of the conditions with the highest priority first.

1. Primary Value Degraded
2. Secondary Value Degraded
3. Diagnostic
4. Configuration Error
5. Calibration Error

MAINT_MASK

The MAINT_MASK parameter will mask any of the failed conditions listed in MAINT_ENABLED. A bit on means that the condition is masked out from alarming and will not be reported.

MAINT_PRI

MAINT_PRI designates the alarming priority of the MAINT_ALM, “Process Alarms” on page 4-12. The default is 0 and the recommended values is 3 to 7.

MAINT_ACTIVE

The MAINT_ACTIVE parameter displays which of the alarms is active. Only the condition with the highest priority will be displayed. This priority is not the same as the MAINT_PRI parameter described above. This priority is hard coded within the device and is not user configurable.

MAINT_ALM

An alarm indicating the device needs maintenance soon. If the condition is ignored, the device will eventually fail.

Advisory Alarms

An advisory alarm indicates informative conditions that do not have a direct impact on the device's primary functions. There are five parameters associated with ADVISE_ALARMS, they are described below.

ADVISE_ENABLED

The ADVISE_ENABLED parameter contains a list of informative conditions that do not have a direct impact on the device's primary functions. Below is a list of the advisories with the highest priority first.

1. NV Writes Deferred
2. SPM Process Anomaly detected

ADVISE_MASK

The ADVISE_MASK parameter will mask any of the failed conditions listed in ADVISE_ENABLED. A bit on means the condition is masked out from alarming and will not be reported.

ADVISE_PRI

ADVISE_PRI designates the alarming priority of the ADVISE_ALM, see "Process Alarms" on page 4-12. The default is 0 and the recommended values are 1 or 2.

ADVISE_ACTIVE

The ADVISE_ACTIVE parameter displays which of the advisories is active. Only the advisory with the highest priority will be displayed. This priority is not the same as the ADVISE_PRI parameter described above. This priority is hard coded within the device and is not user configurable.

ADVISE_ALM

ADVISE_ALM is an alarm indicating advisory alarms. These conditions do not have a direct impact on the process or device integrity.

Recommended Actions for PlantWeb Alerts

RECOMMENDED_ACTION

The RECOMMENDED_ACTION parameter displays a text string that will give a recommended course of action to take based on which type and which specific event of the PlantWeb alerts are active.

Table 4-1.
RB.RECOMMENDED_ACTION

Alarm Type	Failed/Maint/Advise Active Event	Recommended Action Text String
None	None	No action required
Advisory	NV Writes Deferred	Non-volatile writes have been deferred, leave the device powered until the advisory goes away
Maintenance	Configuration Error Primary Value Degraded	Re-write the Sensor Configuration Confirm the operating range of the applied sensor and/or verify the sensor connection and device environment
	Calibration Error Secondary Value Degraded	Retrim the device Verify the ambient temperature is within operating limits
Failed	Electronics Failure	Replace the Device
	HW / SW Incompatible	Verify the Hardware Revision is compatible with the Software Revision
	NV Memory Failure	Reset the device then download the Device Configuration
	Primary Value Failure	Verify the instrument process is within the Sensor range and / or confirm sensor configuration and wiring.
	Secondary Value Failure	Verify the ambient temperature is within operating limits

Sensor Transducer Block

NOTE

When the engineering units of the XD_SCALE are selected, the engineering units in the Transducer Block change to the same units. THIS IS THE ONLY WAY TO CHANGE THE ENGINEERING UNITS IN THE SENSOR TRANSDUCER BLOCK.

Damping

⚠ The damping parameter in the Transducer Block may be used to filter measurement noise. By increasing the damping time, the transmitter will have a slower response time, but will decrease the amount of process noise that is translated to the Transducer Block Primary Value. Because both the LCD and AI Block get input from the Transducer Block, adjusting the damping parameter will effect both blocks.

NOTE

The AI Block has it's own filtering parameter called PV_FTIME. For simplicity, it is better to do filtering in the Transducer Block as damping will be applied to primary value on every sensor update. If filtering is done in AI block, damping will be applied to output every macrocycle. The LCD will display value from Transducer block.

Analog Input (AI) Function Block

Configure the AI block

⚠ A minimum of four parameters are required to configure the AI Block. The parameters are described below with example configurations shown at the end of this section.

CHANNEL

Select the channel that corresponds to the desired sensor measurement. The 644 measures both sensor temperature (channel 1) and terminal temperature (channel 2).

L_TYPE

The L_TYPE parameter defines the relationship of the sensor measurement (sensor temperature) to the desired output temperature of the AI Block. The relationship can be direct or indirect.

Direct

Select direct when the desired output will be the same as the sensor measurement (sensor temperature).

Indirect

Select indirect when the desired output is a calculated measurement based on the sensor measurement (e.g. ohm or mV). The relationship between the sensor measurement and the calculated measurement will be linear.

XD_SCALE and OUT_SCALE

The XD_SCALE and OUT_SCALE each include four parameters: 0%, 100%, engineering units, and precision (decimal point). Set these based on the L_TYPE:

L_TYPE is Direct

When the desired output is the measured variable, set the XD_SCALE to represent the operating range of the process. Set OUT_SCALE to match XD_SCALE.

L_TYPE is Indirect

When an inferred measurement is made based on the sensor measurement, set the XD_SCALE to represent the operating range that the sensor will see in the process. Determine the inferred measurement values that correspond to the XD_SCALE 0 and 100% points and set these for the OUT_SCALE.

NOTE

To avoid configuration errors, only select Engineering Units for XD_SCALE and OUT_SCALE that are supported by the device. The supported units are:

Pressure (Channel 1)	Temperature (Channel 2)
°C	°C
°F	°F
K	K
R	R
Ω	Ω
mV	mV

When the engineering units of the XD_SCALE are selected, this causes the engineering units of the PRIMARY_VALUE_RANGE in the Transducer Block to change to the same units. THIS IS THE ONLY WAY TO CHANGE THE ENGINEERING UNITS IN THE SENSOR TRANSDUCER BLOCK, PRIMARY_VALUE_RANGE parameter.

Configuration Examples

4-wire, Pt 100 $\alpha = 385$

- A11 = Process Temperature
- A12 = Terminal Temperature

Transducer Block

If Host System Supports Methods:

1. Click on Methods
2. Choose Sensor Connections
3. Follow on-screen instruction.

If Host System Doesn't Not Support Methods:

1. Put transducer block into OOS mode.
 - a. Go to MODE_BLK.TARGET
 - b. Choose OOS (0x80)
2. Go to SENSOR_CONNECTION.
 - a. Choose 4-wire (0x4)
3. Go to SENSOR_TYPE.
 - a. Choose PT100A385
4. Put the transducer block back into Auto mode.

AI Blocks (Basic Configuration)⁽¹⁾

AI1 as Process Temperature

1. Put the AI Block into OOS mode.
 - a. Go to MODE_BLK.TARGET
 - b. Choose OOS (0x80)
2. Go to CHANNEL
 - a. Choose Sensor 1
3. Go to L_TYPE
 - a. Choose Direct
4. Go to XD_Scale
 - a. Choose UNITS_INDEX to be °C
5. Go to OUT_SCALE
 - a. Choose UNITS_INDEX to be °C
 - b. Set the 0 and 100 scale to be the same as the PRIMARY_VALUE_RANGE
6. Put the AI Block back into Auto mode.
7. Follow Host Procedure Download Schedule into Block.

AI2 as Terminal Temperature

1. Put the AI Block into OOS mode.
 - a. Go to MODE_BLK.TARGET
 - b. Choose OOS (0x80)
2. Go to CHANNEL
 - a. Choose Body Temperature
3. Go to L_TYPE
 - a. Choose Direct
4. Go to XD_Scale
 - a. Choose UNITS_INDEX to be °C
5. Go to OUT_SCALE
 - a. Choose UNITS_INDEX to be °C
 - b. Set the 0 and 100 scale to be the same as the SECONDARY_VALUE_RANGE
6. Put the AI Block back into Auto mode.
7. Follow Host Procedure Download Schedule into Block.

(1) Configure a minimum of four parameters to get a value out of the AI Block

Filtering

⚠ The filtering feature changes the response time of the device to smooth variations in output readings caused by rapid changes in input. Adjust the filter time constant (in seconds) using the PV_FTIME parameter. Set the filter time constant to zero to disable the filter feature.

Process Alarms

Process Alarm detection is based on the OUT value. Configure the alarm limits of the following standard alarms:

- High (HI_LIM)
- High high (HI_HI_LIM)
- Low (LO_LIM)
- Low low (LO_LO_LIM)

In order to avoid alarm chattering when the variable is oscillating around the alarm limit, an alarm hysteresis in percent of the PV span can be set using the ALARM_HYS parameter. The priority of each alarm is set in the following parameters:

- HI_PRI
- HI_HI_PRI
- LO_PRI
- LO_LO_PRI

Alarm Priority

Alarms are grouped into five levels of priority:

Priority Number	Priority Description
0	The alarm condition is not used.
1	An alarm condition with a priority of 1 is recognized by the system, but is not reported to the operator.
2	An alarm condition with a priority of 2 is reported to the operator.
3-7	Alarm conditions of priority 3 to 7 are advisory alarms of increasing priority.
8-15	Alarm conditions of priority 8 to 15 are critical alarms of increasing priority.

Status Options

Status Options (STATUS_OPTS) supported by the AI block are shown below:

Propagate Fault Forward

If the status from the sensor is Bad, Device failure or Bad, Sensor failure, propagate it to OUT without generating an alarm. The use of these sub-status in OUT is determined by this option. Through this option, the user may determine whether alarming (sending of an alert) will be done by the block or propagated downstream for alarming.

Uncertain if Limited

Set the output status of the Analog Input block to uncertain if the measured or calculated value is limited.

BAD if Limited

Set the output status to Bad if the sensor is violating a high or low limit.

Uncertain if Man Mode

Set the output status of the Analog Input block to uncertain if the actual mode of the block is Man.

NOTE

The instrument must be in Out of Service mode to set the status option.

Advanced Features

The AI Function Block provides added capability through the addition of the following parameters:

ALARM_TYPE

ALARM_TYPE allows one or more of the process alarm conditions detected by the AI function block to be used in setting its OUT_D parameter.

OUT_D

OUT_D is the discrete output of the AI function block based on the detection of process alarm condition(s). This parameter may be linked to other function blocks that require a discrete input based on the detected alarm condition.

LCD Transducer Block

The LCD meter connects directly to the 644 electronics FOUNDATION fieldbus output board. The meter indicates output and abbreviated diagnostic messages.

The first line of five characters displays the sensor being measured.

If the measurement is in error, "Error" appears on the first line. The second line indicates if the device or the sensor is causing the error.

Each parameter configured for display will appear on the LCD for a brief period before the next parameter is displayed. If the status of the parameter goes bad, the LCD will also cycle diagnostics following the displayed variable:

Custom Meter Configuration

Shipped from the factory, Parameter #1 is configured to display the Primary Variable (temperature) from the LCD Transducer Block. Parameters 2 – 4 are not configured. To change the configuration of Parameter #1 or to configure additional parameters 2 – 4, use the configuration parameters below.

The LCD Transducer Block can be configured to sequence four different process variables as long as the parameters are sourced from a function block that is scheduled to execute within the 644 temperature transmitter. If a function block is scheduled in the 644 that links a process variable from another device on the segment, that process variable can be displayed on the LCD.

DISPLAY_PARAM_SEL

The DISPLAY_PARAM_SEL parameter specifies how many process variables will be displayed. Select up to four display parameters.

BLK_TAG_#⁽¹⁾

Enter the Block Tag of the function block that contains the parameter to be displayed. The default function block tags from the factory are:

TRANSDUCER
AI 1300
AI 1400
PID 1500

BLK_TYPE_#⁽¹⁾

Enter the Block Type of the function block that contains the parameter to be displayed. This parameter is generally selected via a drop-down menu with a list of possible function block types. (e.g. Transducer, PID, AI, etc.)

PARAM_INDEX_#⁽¹⁾

The PARAM_INDEX_# parameter is generally selected via a drop-down menu with a list of possible parameter names based upon what is available in the function block type selected. Choose the parameter to be displayed.

CUSTOM_TAG_#⁽¹⁾

The CUSTOM_TAG_# is an optional user-specified tag identifier that can be configured to be displayed with the parameter in place of the block tag. Enter a tag of up to five characters.

UNITS_TYPE_#⁽¹⁾

The UNITS_TYPE_# parameter is generally selected via a drop-down menu with three options: AUTO, CUSTOM, or NONE. Select AUTO only when the parameter to be displayed is pressure, temperature, or percent. For other parameters, select CUSTOM and be sure to configure the CUSTOM_UNITS_# parameter. Select NONE if the parameter is to be displayed without associated units.

CUSTOM_UNITS_#⁽¹⁾

Specify custom units to be displayed with the parameter. Enter up to six characters. To display Custom Units the UNITS_TYPE_# must be set to CUSTOM.

OPERATION AND MAINTENANCE

Overview

This section contains information on operation and maintenance procedures.

METHODS AND MANUAL OPERATION

Each FOUNDATION fieldbus host or configuration tool has different ways of displaying and performing operations. Some hosts will use Device Descriptions (DD) and DD Methods to complete device configuration and will display data consistently across platforms. The DD can found on www.rosemount.com. There is no requirement that a host or configuration tool support these features.

The information in this section will describe how to use methods in a general fashion. In addition, if your host or configuration tool does not support methods this section will cover manually configuring the parameters involved with each method operation. For more detailed information on the use of methods, see your host or configuration tool manual.

(1) # represents the specified parameter number.

Troubleshooting Guides

Figure 4-1. 644 troubleshooting flowchart

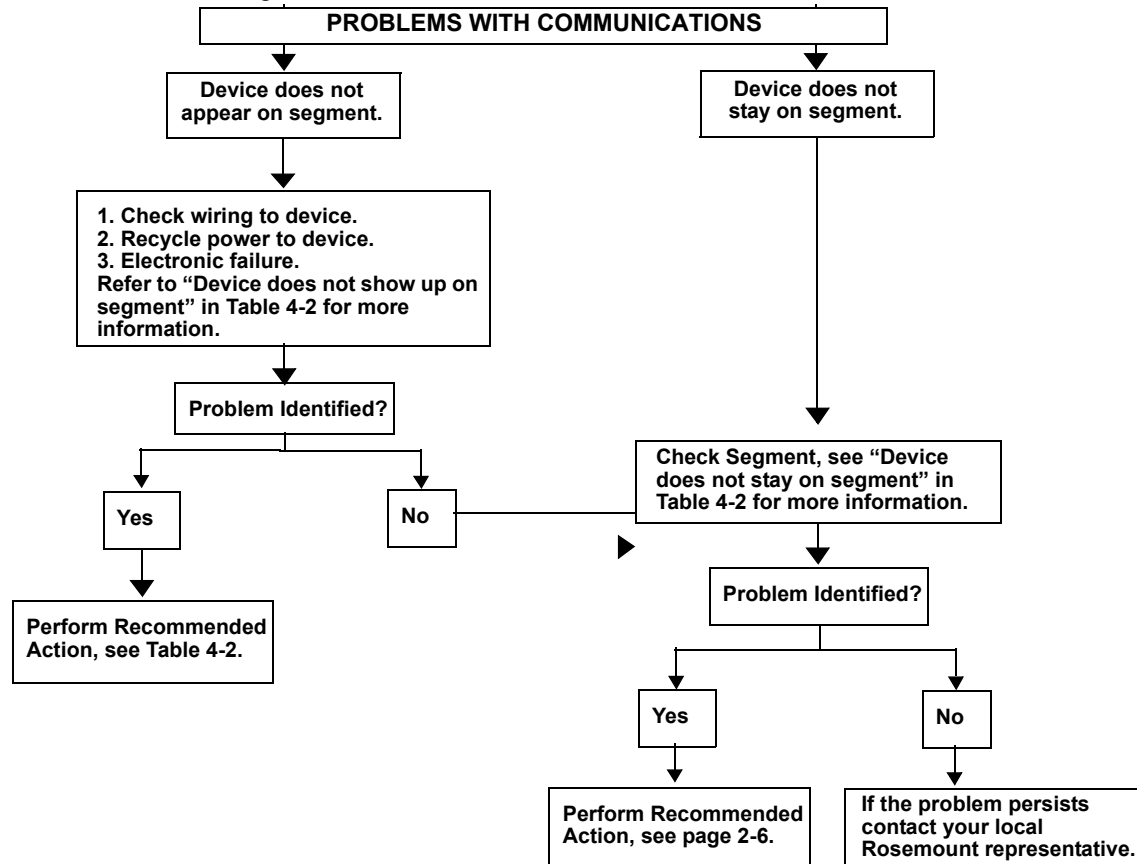

FOUNDATION Fieldbus

Table 4-2. Troubleshooting guide.

Symptom ⁽¹⁾	Cause	Recommended Actions
Device does not show up on segment	Unknown	Recycle power to device
	No power to device	1. Ensure the device is connected to the segment. 2. Check voltage at terminals. There should be 9–32Vdc. 3. Check to ensure the device is drawing current. There should be approximately 10.5 mA nominal (11 mA max.)
	Segment problems	
	Electronics failing	1. Replace device.
Device does not stay on segment ⁽²⁾	Incompatible network settings	Change host network parameters. Refer to host documentation for procedure.
	Incorrect signal levels. Refer to host documentation for procedure.	1. Check for two terminators. 2. Excess cable length. 3. Bad Power supply or conditioner
	Excess noise on segment. Refer to host documentation for procedure.	1. Check for incorrect grounding. 2. Check for correct shielded wire. 3. Tighten wire connections. 4. Check for corrosion or moisture on terminals. 5. Check for Bad power supply.
	Electronics failing	1. Replace device.
	Other	1. Check for water around the transmitter.

(1) The corrective actions should be done with consultation of your system integrator.

(2) Wiring and installation 31.25 kbit/s, voltage mode, wire medium application guide AG-140 available from the fieldbus Foundation.

Rosemount 644

Figure 4-2. Problems with communications flowchart

FOUNDATION Fieldbus

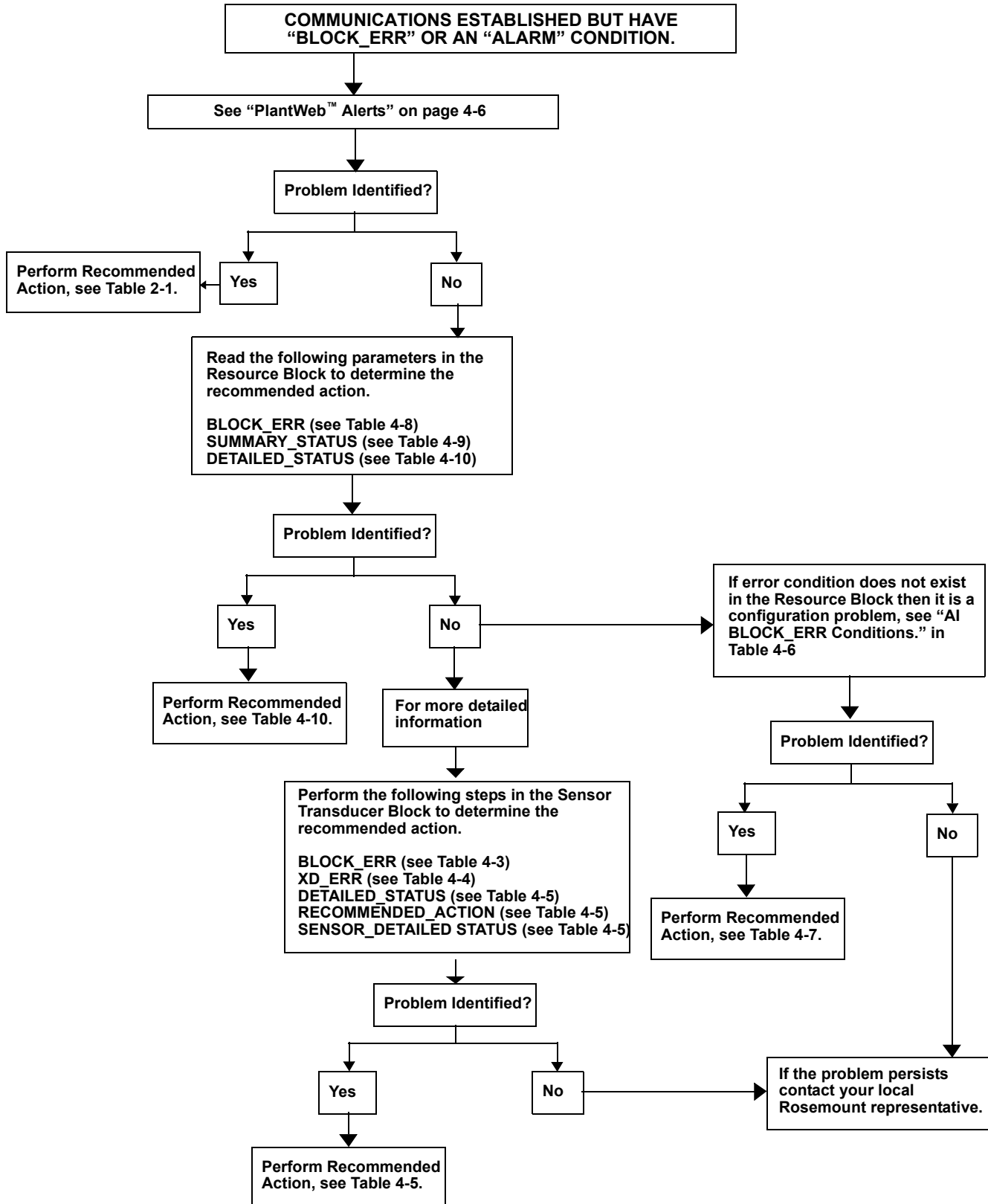

Sensor Transducer Block Sensor Calibration, Lower and Upper Trim Methods

 In order to calibrate the transmitter, run the Lower and Upper Trim Methods. If your system does not support methods, manually configure the Transducer Block parameters listed below.

1. Set MODE_BLK.TARGET to OOS
2. Set SENSOR_CAL_METHOD to User Trim
3. Set CAL_UNIT to supported engineering units in the Transducer Block
4. Apply temperature that corresponds to the lower calibration point and allow the temperature to stabilize. The temperature must be between the range limits defined in PRIMARY_VALUE_RANGE.
5. Set values of CAL_POINT_LO to correspond to the temperature applied by the sensor.
6. Apply temperature, temperature corresponding to the upper calibration
7. Allow temperature to stabilize.
8. Set CAL_POINT_HI

NOTE

CAL_POINT_HI must be within PRIMARY_VALUE_RANGE and greater than CAL_POINT_LO + CAL_MIN_SPAN

9. Set SENSOR_CAL_DATE to the current date.
10. Set SENSOR_CAL_WHO to the person responsible for the calibration.
11. Set SENSOR_CAL_LOC to the calibration location.
- 12.
13. Set MODE_BLK.TARGET to AUTO

NOTE

If trim fails the transmitter will automatically revert to factory trim.

Excessive correction or sensor failure could cause device status to read "calibration error." To clear this, trim the transmitter

Recall Factory Trim

⚠ To recall a factory trim on the transmitter, run the Recall Factory Trim. If your system does not support methods, manually configure the Transducer Block parameters listed below.

1. Set MODE_BLK.TARGET to OOS
2. Set SENSOR_CAL_METHOD to Factory Trim.
3. Set SET_FACTORY_TRIM to Recall.
4. Set SENSOR_CAL_DATE to the current date.
5. Set SENSOR_CAL_WHO to the person responsible for the calibration.
6. Set SENSOR_CAL_LOC to the calibration location.
7. Set MODE_BLK.TARGET to AUTO.

NOTE

When sensor type is changed, the transmitter reverts to the factory trim. Changing sensor type causes you to loose any trim performed on the transmitter.

Table 4-3. Sensor Transducer Block BLOCK_ERR messages

Condition Name and Description
Other
Out of Service: The actual mode is out of service.

Table 4-4. Sensor Transducer Block XD_ERR messages

Condition Name and Description
Electronics Failure: An electrical component failed.
I/O Failure: An I/O failure occurred.
Software Error: The software has detected an internal error.
Calibration Error: An error occurred during calibration of the device.
Algorithm Error: The algorithm used in the transducer block produced an error due to overflow, data reasonableness failure, etc.

Diagnostics

Table 4-5 lists the potential errors and the possible corrective actions for the given values. The corrective actions are in order of increasing system level compromises. The first step should always be to reset the transmitter and then if the error persists, try the steps in Table 4-5. Start with the first corrective action and then try the second.

Table 4-5. Sensor Transducer Block STB.SENSOR_DETAILED_STATUS messages

STB.SENSOR_DETAILED_STATUS	Description
Invalid Configuration	Wrong sensor connection with wrong sensor type
ASIC RCV Error	The micro detected a chksum or start/stop bit failure with ASIC communication
ASIC TX Error	The A/D ASIC detected a communication error
ASIC Interrupt Error	ASIC interrupts are too fast or slow
Reference Error	Reference resistors are greater than 25% of known value
ASIC Configuration Error	Citadel registers were not written correctly. (Also CALIBRATION_ERR)
Sensor Open	Open sensor detected
Sensor Shorted	Shorted sensor detected
Terminal Temperature Failure	Open PRT detected
Sensor Out of Operating Range	Sensor readings have gone beyond PRIMARY_VALUE_RANGE values
Sensor beyond operating limits	Sensor readings have gone below 2% of lower range or above 6% of upper range of sensor.
Terminal Temperature Out of Operating Range	PRT readings have gone beyond SECONDARY_VALUE_RANGE values
Terminal Temperature Beyond Operating Limits	PRT readings have gone below 2% of lower range or above 6% of upper range of PRT. (These ranges are calculated and are not the actual range of the PRT which is a PT100 A385)
Sensor Degraded	For RTDs, this is excessive EMF detected. This is thermocouple degradation for thermocouples.
Sensor Error	The user trim has failed due to excessive correction or sensor failure during the trim method

FOUNDATION Fieldbus

Rosemount 644

Analog Input (AI) Function Block

Status

Along with the measured or calculated PV value, every FOUNDATION Fieldbus block passes an additional parameter called STATUS. The PV and STATUS are passed from the Transducer Block to the Analog Input Block. The STATUS can be one of the following: GOOD, BAD, or UNCERTAIN. When there are no problems detected by the self-diagnostics of the block, the STATUS will be GOOD. If a problem occurs with the hardware in the device, or, the quality of the process variable is compromised for some reason, the STATUS will become either BAD or UNCERTAIN depending upon the nature of the problem. It is important that the Control Strategy that makes use of the Analog Input Block is configured to monitor the STATUS and take action where appropriate when the STATUS is no longer GOOD.

Simulation

⚠ Simulate replaces the channel value coming from the Sensor Transducer Block. For testing purposes, it is possible to manually drive the output of the Analog Input Block to a desired value. There are two ways to do this.

Manual Mode

To change only the OUT_VALUE and not the OUT_STATUS of the AI Block, place the TARGET MODE of the block to MANUAL. Then, change the OUT_VALUE to the desired value.

Simulate

1. If the SIMULATE switch is in the OFF position, move it to the ON position. If the SIMULATE jumper is already in the ON position, you must move it to off and place it back in the ON position.

NOTE

As a safety measure, the switch must be reset every time power is interrupted to the device in order to enable SIMULATE. This prevents a device that is tested on the bench from getting installed in the process with SIMULATE still active.

2. To change both the OUT_VALUE and OUT_STATUS of the AI Block, set the TARGET MODE to AUTO.
3. Set SIMULATE_ENABLE_DISABLE to 'Active'.
4. Enter the desired SIMULATE_VALUE to change the OUT_VALUE and SIMULATE_STATUS_QUALITY to change the OUT_STATUS. If errors occur when performing the above steps, be sure that the SIMULATE jumper has been reset after powering up the device.

Table 4-6. AI BLOCK_ERR Conditions.

Condition Number	Condition Name and Description
0	Other
1	Block Configuration Error: the selected channel carries a measurement that is incompatible with the engineering units selected in XD_SCALE, the L_TYPE parameter is not configured, or CHANNEL = zero.
3	Simulate Active: Simulation is enabled and the block is using a simulated value in its execution.
7	Input Failure/Process Variable has Bad Status: The hardware is bad, or a bad status is being simulated.
14	Power Up
15	Out of Service: The actual mode is out of service.

Table 4-7. Troubleshooting the AI block

Symptom	Possible Causes	Recommended Actions
Bad or no temperature readings (Read the AI "BLOCK_ERR" parameter)	BLOCK_ERR reads OUT OF SERVICE (OOS)	1. AI Block target mode target mode set to OOS. 2. Resource Block OUT OF SERVICE.
	BLOCK_ERR reads CONFIGURATION ERROR	1. Check CHANNEL parameter (see "CHANNEL" on page 2-9) 2. Check L_TYPE parameter (see "L_TYPE" on page 2-9) 3. Check XD_SCALE engineering units. (see "XD_SCALE and OUT_SCALE" on page 2-10)
	BLOCK_ERR reads POWERUP	Download Schedule into block. Refer to host for downloading procedure.
	BLOCK_ERR reads BAD INPUT	1. Sensor Transducer Block Out Of Service (OOS) 2. Resource Block Out of Service (OOS)
	No BLOCK_ERR but readings are not correct. If using Indirect mode, scaling could be wrong.	1. Check XD_SCALE parameter. 2. Check OUT_SCALE parameter. (see "XD_SCALE and OUT_SCALE" on page 2-10)
	No BLOCK_ERR. Sensor needs to be calibrated or Zero trimmed.	See Section 3: Operation and Maintenance to determine the appropriate trimming or calibration procedure.
OUT parameter status reads UNCERTAIN and substatus reads EngUnitRangViolation.	Out_ScaleEU_0 and EU_100 settings are incorrect.	See "XD_SCALE and OUT_SCALE" on page 2-10.

Rosemount 644

Resource Block

This section describes error conditions found in the Resource block. Read Table 4-8 through Table 4-10 to determine the appropriate corrective action.

Table 4-8. Resource Block BLOCK_ERR messages

Block Errors

Table 4-8 lists conditions reported in the BLOCK_ERR parameter.

Condition Name and Description
Other
Device Needs Maintenance Now
Memory Failure: A memory failure has occurred in FLASH, RAM, or EEPROM memory
Lost NV Data: Non-volatile data that is stored in non-volatile memory has been lost.
Device Needs Maintenance Now
Out of Service: The actual mode is out of service.

Table 4-9. Resource Block SUMMARY_STATUS messages

Condition Name
No repair needed
Repairable
Call Service Center

Table 4-10. Resource Block RB.DETAILED_STATUS

RB.DETAILED_STATUS	Description
Sensor Transducer block error.	Active when any SENSOR_DETAILED_STAUS bit is on
Manufacturing Block integrity error	The manufacturing block size, revision, or checksum is wrong
Hardware/software incompatible	Verify the manufacturing block revision and the hardware revision are correct/compatible with the software revision.
Non-volatile memory integrity error	Invalid checksum on a block of NV data
ROM integrity error	Invalid application code checksum
Lost deferred NV data	Device has been power-cycled while non-volatile writes were being deferred to prevent premature memory failure, the write operations have been deferred.
NV Writes Deferred	A high number of writes has been detected to non-volatile memory. To prevent premature failure, the write operations have been deferred.

LCD Transducer block

This section describes error conditions found in the LCD Transducer Block. Read Table 4-11 and to determine the appropriate corrective action.

Self Test Procedure for the LCD

The SELF_TEST parameter in the Resource block will test LCD segments. When running, the segments of the display should light up for about five seconds.

If your host system supports methods refer to your host documentation on how to run the “Self Test” method. If your host system does not support methods than you can run this test manually be following the steps below.

1. Put Resource block into “OOS” (Out of Service).
2. Go to the parameter called “SELF_TEST” and write the value Self test (0x2).
3. Observe the LCD screen when you are doing this. All of the segments should light up.
4. Put the Resource block back into “AUTO”.

Table 4-11. LCD Transducer Block BLOCK_ERR messages

Condition Name and Description
Other
Out of Service: The actual mode is out of service.

Symptom	Possible Causes	Recommended Action
The LCD displays “DSPLY#INVALID.” Read the BLOCK_ERR and if it says “BLOCK CONFIGURATION” perform the Recommended Action	One or more of the display parameters are not configured properly.	See “LCD Transducer Block” on page 2-16.
The Bar Graph and the AI.OUT readings do not match.	The OUT_SCALE of the AI block is not configured properly.	See “Analog Input (AI) Function Block” on page 2-9 and “Display bar graph” on page 2-18.
“644” is being displayed or not all of the values are being displayed.	The LCD block parameter “DISPLAY_PARAMETER_SELECT is not properly configured.	See “LCD Transducer Block” on page 2-16.
The display reads OOS	The resource and or the LCD Transducer block are OOS.	Verify that both blocks are in “AUTO.”
The display is hard to read.	Some of the LCD segments may have gone bad.	See XXXX (Self Test). If some of the segment is bad, replace the LCD.
	Device is out o the temperature limit for the LCD. (-20 to 80 °C)	Check ambient temperature of the device.

Rosemount 644

Appendix A Specifications and Reference Data

HART and Foundation Fieldbus Specifications	page A-1
Foundation Fieldbus Specifications	page A-4
4–20 mA / HART Specifications	page A-6
Dimensional Drawings	page A-10
Ordering Information	page A-12
Additional Information	page A-14
Stainless Steel Housing	page A-16

HART AND FOUNDATION FIELDBUS SPECIFICATIONS

Functional

Inputs

User-selectable; sensor terminals rated to 42.4 V dc. See “Accuracy” on page A-8 for sensor options.

Output

Single 2-wired device with either 4–20 mA/HART, linear with temperature or input; or a completely digital output with FOUNDATION fieldbus communication (ITK 4.5 compliant).

Isolation

Input/output isolation tested to 500 V DC/AC rms (707 V DA) at 50/60 Hz

Local Display

The optional five-digit integral LCD Display includes a floating or fixed decimal point. It can also display engineering units (°F, °C, °R, K, Ω , and millivolts), milliampere, and percent of span. The display can be configured to alternate between selected display options. Display settings are preconfigured at the factory according to the standard transmitter configuration. They can be reconfigured in the field using either HART or FOUNDATION fieldbus communications.

Humidity Limits

0–99% relative humidity

Update Time

≤ 0.5 seconds

Physical

Electrical Connections

Model	Power and Sensor Terminals
644H	Compression screws permanently fixed to terminal block
644R	Compression screw permanently fixed to front panel

WAGO® Spring clamp terminals are optional (option code G5)

HART Communicator Connections

Communication Terminals	
644H	Clips permanently fixed to terminal block
644R	Clips permanently fixed to front panel

Materials of Construction

Electronics Housing and Terminal Block	
644H	Noryl® glass reinforced
644R	Lexan® polycarbonate

Enclosure (Option code J5 or J6)	
Housing	Low-copper aluminum
Paint	Polyurethane
Cover O-ring	Buna-N

Mounting

The 644R attaches directly to a wall or a DIN rail. The 644H installs in a connection head or universal head mounted directly on a sensor assembly, apart from a sensor assembly using a universal head, or to a DIN rail using an optional mounting clip.

Weight

Code	Options	Weight
644H	HART, Head Mount Transmitter	96 g (3.39 oz)
644H	FOUNDATION fieldbus, Head Mount Transmitter	92 g (3.25 oz)
644R	HART, Rail Mount Transmitter	174 g (6.14 oz)
M5	LCD Display	38 g (1.34 oz)
J5, J6	Universal Head, Standard Cover	577 g (20.35 oz)
J5, J6	Universal Head, Meter Cover	667 g (23.53 oz)

Enclosure Ratings (644H)

All option codes (S1, S2, S3, S4, J5 and J6) are NEMA 4X, IP66, and IP68. Option code J6 is CSA Enclosure Type 4X.

Performance

EMC (ElectroMagnetic Compatibility) NAMUR NE 21 Standard

The 644H HART meets the requirements for NAMUR NE 21 Rating. (Hardware Rev 26 and later for HART devices.)

Susceptibility	Parameter	Influence
ESD	<ul style="list-style-type: none"> 6 kV contact discharge 8 kV air discharge 	HART None
Radiated	80 – 1000 MHz at 10 V/m AM	< 0.5%
Burst	1 kV for I.O.	None
Surge	<ul style="list-style-type: none"> 0.5 kV line–line 1 kV line–ground (I.O. tool) 	None
Conducted	150 kHz to 80 MHz at 10 V	< 0.5%

CE Mark

The 644 meets all requirements listed under IEC 61326: Amendment 1, 1998.

Power Supply Effect

Less than ±0.005% of span per volt

Stability

RTDs and thermocouples have a stability of ±0.15% of output reading or 0.15 °C (whichever is greater) for 24 months

Self Calibration

The analog-to-digital measurement circuitry automatically self-calibrates for each temperature update by comparing the dynamic measurement to extremely stable and accurate internal reference elements.

Vibration Effect

The 644 is tested to the following specifications with no effect on performance:

Frequency	Vibration
10 to 60 Hz	0.21 mm displacement
60 to 500 Hz	3 g peak acceleration

Sensor Connections

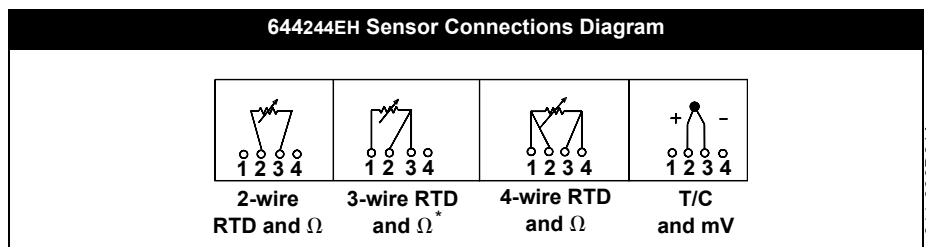

* Rosemount Inc. provides 4-wire sensors for all single element RTDs. You can use these RTDs in 3-wire configurations by leaving the unneeded leads disconnected and insulated with electrical tape.

Rosemount Conformance to Specifications

A Rosemount product not only meets its published specifications, but most likely exceeds them. Advanced manufacturing techniques and the use of Statistical Process Control provide specification conformance to at least $\pm 3\sigma$ ⁽¹⁾. Our commitment to continual improvement ensures that product design, reliability, and performance will improve annually.

For example, the Reference Accuracy distribution for the 644 is shown to the right. Our Specification Limits are $\pm 0.15^\circ\text{C}$, but, as the shaded area shows, approximately 68% of the units perform three times better than the limits. Therefore, it is very likely that you will receive a device that performs much better than our published specifications.

Conversely, a vendor who “grades” product without using Process Control, or who is not committed to $\pm 3\sigma$ performance, will ship a higher percentage of units that are barely within advertised specification limits.

(1) Sigma (σ) is a statistical symbol to designate the standard deviation from the mean value of a normal distribution.

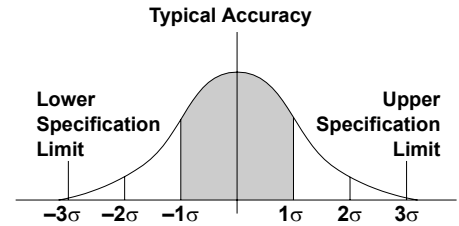

Accuracy distribution shown is for the 644, Pt 100 RTD sensor, Range 0 to 100 °C

3144-GRAPH

FOUNDATION FIELDBUS SPECIFICATIONS

Function Blocks

Resource Block

- The resource block contains physical transmitter information including available memory, manufacture identification, device type, software tag, and unique identification.

Transducer Block

- The transducer block contains the actual temperature measurement data, including sensor 1 and terminal temperature. It includes information about sensor type and configuration, engineering units, linearization, reranging, damping, temperature correction, and diagnostics.

LCD Block

- The LCD block is used to configure the local display, if a LCD Display is being used.

Analog Input (AI)

- Processes the measurement and makes it available on the fieldbus segment
- Allows filtering, alarming, and engineering unit changes.

PID Block

- The transmitter provides control functionality with one PID function block in the transmitter. The PID block can be used to perform single loop, cascade, or feedforward control in the field.

Instantiable Function Blocks

- All the function blocks used by the transmitter are instantiable, meaning the total number of function blocks is only limited by the physical memory available in the transmitter. Since only the instantiable blocks can use physical memory, any combination of function blocks can be used at any given time as long as the physical memory size is not violated.

Block	Execution Time (milliseconds)
Resource	–
Transducer	–
LCD Block	–
Analog Input 1	45
Analog Input 2	45
PID 1	60

Turn-on Time

Performance within specifications in less than 20 seconds after power is applied, when damping value is set to 0 seconds.

Status

If self-diagnostics detect a sensor burnout or a transmitter failure, the status of the measurement will be updated accordingly. Status may also send the PID output to a safe value.

Power Supply

Powered over FOUNDATION Fieldbus with standard fieldbus power supplies. The transmitter operates between 9.0 and 32.0 VDC, 11 mA maximum. The power terminals are rated to 42.4 VDC max.

Alarms

The AI function block allows the user to configure the alarms to HI-HI, HI, LO, or LO-LO with a variety of priority levels and hysteresis settings.

Backup Link Active Scheduler (LAS)

The transmitter is classified as a device link master, which means it can function as a Link Active Scheduler (LAS) if the current link master device fails or is removed from the segment.

The host or other configuration tool is used to download the schedule for the application to the link master device. In the absence of a primary link master, the transmitter will claim the LAS and provide permanent control for the H1 segment.

FOUNDATION Fieldbus Parameters

Schedule Entries	25 ⁽¹⁾
Links	16 ⁽¹⁾
Virtual Communications Relationships (VCR)	12 ⁽¹⁾

(1) Minimum quantity.

Software Upgrade in the Field

Software for the 644 with FOUNDATION fieldbus will be easy to upgrade in the field. Users will be able to take advantage of software enhancements by loading new application software into the device memory.

4–20 mA / HART SPECIFICATIONS

Communication Requirements

Transmitter power terminals are rated to 42.4 V DC. A HART Communicator requires a loop resistance between 250 – 1100 ohms. The 644 HART device does not communicate when power is below 12 V DC at the transmitter terminals.

Power Supply

An external power supply is required for HART devices. The transmitter operates on 12.0 to 42.4 VDC transmitter terminal voltage with load resistance between 250 and 660 ohms. A minimum of 17.75 VDC power supply is required with a load of 250 ohms. Transmitter power terminals are rated to 42.4 V DC.

Maximum Load = 40.8 x (Supply Voltage – 12.0)

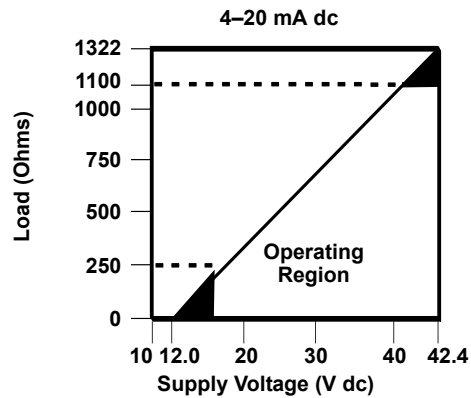

Temperature Limits

	Operating Limit	Storage Limit
With LCD Display	–4 to 185 °F –20 to 85 °C	–50 to 185 °F –45 to 85 °C
Without LCD Display	–40 to 185 °F –40 to 85 °C	–58 to 248 °F –50 to 120 °C

Hardware and Software Failure Mode

The 644 features software driven alarm diagnostics. The independent circuit is designed to provide backup alarm output if the microprocessor software fails. The alarm directions (HIGH/LO) are user-selectable using the failure mode switch. If failure occurs, the position of the switch determines the direction in which the output is driven (HI or LO). The switch feeds into the digital-to-analog (D/A) converter, which drives the proper alarm output even if the microprocessor fails. The values at which the transmitter drives its output in failure mode depends on whether it is configured to standard, custom, or NAMUR-compliant (NAMUR recommendation NE 43, June 1997) operation. Table 1 shows the alarm ranges available for the device to be configured to.

TABLE 1. Available Alarm Range⁽¹⁾

	Standard	NAMUR- NE 43 Compliant
Linear Output:	$3.9 \leq I^{(2)} \leq 20.5$	$3.8 \leq I \leq 20.5$
Fail High:	$21 \leq I \leq 23$	$21 \leq I \leq 23$
Fail Low:	$3.5 \leq I \leq 3.75$	$3.5 \leq I \leq 3.6$

(1) Measured in milliamperes.

(2) I = Process Variable (current output).

Custom Alarm and Saturation Level

Custom factory configuration of alarm and saturation level is available with option code C1 for valid values. These values can also be configured in the field using a HART Communicator.

Turn-on Time

Performance within specifications in less than 5.0 seconds after power is applied, when damping value is set to 0 seconds.

Transient Protection

The Rosemount 470 prevents damage from transients induced by lightning, welding, or heavy electrical equipment. For more information, refer to the 470 Product Data Sheet (document number 00813-0100-4191).

Rosemount 644

Accuracy

TABLE 2. Rosemount 644 Input Options and Accuracy.

Sensor Options	Sensor Reference	Input Ranges		Recommended Min. Span ⁽¹⁾		Digital Accuracy ⁽²⁾		D/A Accuracy ⁽³⁾
		°C	°F	°C	°F	°C	°F	
2-, 3-, 4-wire RTDs								
Pt 100	IEC 751, 1995 ($\alpha = 0.00385$)	-200 to 850	-328 to 1562	10	18	± 0.15	± 0.27	±0.03% of span
Pt 100	JIS 1604, 1981 ($\alpha = 0.003916$)	-200 to 645	-328 to 1193	10	18	± 0.15	± 0.27	±0.03% of span
Pt 200	IEC 751, 1995 ($\alpha = 0.00385$)	-200 to 850	-328 to 1562	10	18	± 0.27	± 0.49	±0.03% of span
Pt 500	IEC 751, 1995 ($\alpha = 0.00385$)	-200 to 850	-328 to 1562	10	18	± 0.19	± 0.34	±0.03% of span
Pt 1000	IEC 751, 1995 ($\alpha = 0.00385$)	-200 to 300	-328 to 572	10	18	± 0.19	± 0.34	±0.03% of span
Ni 120	Edison Curve No. 7	-70 to 300	-94 to 572	10	18	± 0.15	± 0.27	±0.03% of span
Cu 10	Edison Copper Winding No. 15	-50 to 250	-58 to 482	10	18	±1.40	± 2.52	±0.03% of span
Thermocouples ⁽⁴⁾								
Type B ⁽⁵⁾	NIST Monograph 175, IEC 584	100 to 1820	212 to 3308	25	45	± 0.77	± 1.39	±0.03% of span
Type E	NIST Monograph 175, IEC 584	-50 to 1000	-58 to 1832	25	45	± 0.20	± 0.36	±0.03% of span
Type J	NIST Monograph 175, IEC 584	-180 to 760	-292 to 1400	25	45	± 0.35	± 0.63	±0.03% of span
Type K ⁽⁶⁾	NIST Monograph 175, IEC 584	-180 to 1372	-292 to 2502	25	45	± 0.50	± 0.90	±0.03% of span
Type N	NIST Monograph 175, IEC 584	-200 to 1300	-328 to 2372	25	45	± 0.50	± 0.90	±0.03% of span
Type R	NIST Monograph 175, IEC 584	0 to 1768	32 to 3214	25	45	± 0.75	± 1.35	±0.03% of span
Type S	NIST Monograph 175, IEC 584	0 to 1768	32 to 3214	25	45	± 0.70	± 1.26	±0.03% of span
Type T	NIST Monograph 175, IEC 584	-200 to 400	-328 to 752	25	45	± 0.35	± 0.63	±0.03% of span
DIN Type L	DIN 43710	-200 to 900	-328 to 1652	25	45	± 0.35	± 0.63	±0.03% of span
DIN Type U	DIN 43710	-200 to 600	-328 to 1112	25	45	± 0.35	± 0.63	±0.03% of span
Type W5Re/W26Re	ASTM E 988-96	0 to 2000	32 to 3632	25	45	± 0.70	± 1.26	±0.03% of span
Millivolt Input		-10 to 100 mV		3 mV		±0.015 mV		±0.03% of span
2-, 3-, 4-wire Ohm Input		0 to 2000 ohms		20 ohm		±0.45 ohm		±0.03% of span

- (1) No minimum or maximum span restrictions within the input ranges. Recommended minimum span will hold noise within accuracy specification with damping at zero seconds.
- (2) The published digital accuracy applies over the entire sensor input range. Digital output can be accessed by HART or FOUNDATION fieldbus Communications or Rosemount control system.
- (3) Total Analog accuracy is the sum of digital and D/A accuracies.
- (4) Total digital accuracy for thermocouple measurement: sum of digital accuracy +0.5 °C.
- (5) Digital accuracy for NIST Type B T/C is ±3.0 °C (±5.4 °F) from 100 to 300 °C (212 to 572 °F).
- (6) Digital accuracy for NIST Type K T/C is ±0.70 °C (±1.26 °F) from -180 to -90 °C (-292 to -130 °F).

Accuracy Example (HART devices)

When using a Pt 100 ($\alpha = 0.00385$) sensor input with a 0 to 100 °C span:

- Digital accuracy = ±0.15 °C
- D/A accuracy = ±0.03% of 100 °C or ±0.03 °C
- Total accuracy = ±0.18 °C.

Accuracy Example (Foundation fieldbus devices)

When using a Pt 100 ($\alpha = 0.00385$) sensor input:

- Total accuracy = ±0.15 °C.
- No D/A accuracy effects apply

Ambient Temperature Effect

TABLE 3. Ambient Temperature Effect

Sensor Options	Temperature Effects per 1.0 °C (1.8 °F) Change in Ambient Temperature ⁽¹⁾	Range	D/A Effect
2-, 3-, 4-wire RTDs			
Pt 100 (($\alpha = 0.00385$))	0.003 °C (0.0054 °F)	Entire Sensor Input Range	0.001% of span
Pt 100 ($\alpha = 0.003916$)	0.003 °C (0.0054 °F)	Entire Sensor Input Range	0.001% of span
Pt 200	0.004 °C (0.0072 °F)	Entire Sensor Input Range	0.001% of span
Pt 500	0.003 °C (0.0054 °F)	Entire Sensor Input Range	0.001% of span
Pt 1000	0.003 °C (0.0054 °F)	Entire Sensor Input Range	0.001% of span
Ni 120	0.003 °C (0.0054 °F)	Entire Sensor Input Range	0.001% of span
Cu 10	0.03 °C (0.054 °F)	Entire Sensor Input Range	0.001% of span
Thermocouples			
Type B	0.014 °C	$R \geq 1000^{\circ}\text{C}$	0.001% of span
	0.032 °C – (0.0025% of (R – 300))	$300^{\circ}\text{C} \leq R < 1000^{\circ}\text{C}$	0.001% of span
	0.054 °C – (0.011% of (R – 100))	$100^{\circ}\text{C} \leq R < 300^{\circ}\text{C}$	0.001% of span
Type E	0.005 °C +(0.00043% of R)	All	0.001% of span
Type J	0.0054 °C +(0.0029% of R)	$R \geq 0^{\circ}\text{C}$	0.001% of span
	0.0054 °C + (0.0025% of absolute value R)	$R < 0^{\circ}\text{C}$	0.001% of span
Type K	0.0061 °C +(0.00054% of R)	$R \geq 0^{\circ}\text{C}$	0.001% of span
	0.0061 °C + (0.0025% of absolute value R)	$R < 0^{\circ}\text{C}$	0.001% of span
Type N	0.0068 °C +(0.00036% of R)	All	0.001% of span
Type R, S, W5Re/W26Re	0.016 °C	$R \geq 200^{\circ}\text{C}$	0.001% of span
	0.023 °C – (0.0036% of R)	$R < 200^{\circ}\text{C}$	0.001% of span
Type T	0.0064 °C	$R \geq 0^{\circ}\text{C}$	0.001% of span
	0.0064 °C +(0.0043% of absolute value R)	$R < 0^{\circ}\text{C}$	0.001% of span
DIN Type L	0.0054 °C + (0.00029% of R)	$R \geq 0^{\circ}\text{C}$	0.001% of span
	0.0054 °C +(0.0025% of absolute value R)	$R < 0^{\circ}\text{C}$	0.001% of span
DIN Type U	0.0064 °C	$R \geq 0^{\circ}\text{C}$	0.001% of span
	0.0064 °C +(0.0043% of absolute value R)	$R < 0^{\circ}\text{C}$	0.001% of span
Millivolt Input	0.0005 mV	Entire Sensor Input Range	0.001% of span
2-, 3-, 4-wire Ohm	0.0084 Ω	Entire Sensor Input Range	0.001% of span

(1) Change in ambient is with reference to the calibration temperature of the transmitter 68 °F (20 °C) from factory.

Transmitters can be installed in locations where the ambient temperature is between –40 and 85 °C (–40 and 185 °F). In order to maintain excellent accuracy performance, each transmitter is individually characterized over this ambient temperature range at the factory.

Temperature Effects Example (HART devices)

When using a Pt 100 ($\alpha = 0.00385$) sensor input with a 0–100 °C span at 30 °C ambient temperature:

- Digital Temperature Effects: $0.003^{\circ}\text{C} \times (30 - 20) = 0.03^{\circ}\text{C}$
- D/A Effects: $[0.001\% \text{ of } 100] \times (30 - 20) = 0.01^{\circ}\text{C}$
- Worst Case Error: Digital + D/A + Digital Temperature Effects + D/A Effects = $0.15^{\circ}\text{C} + 0.03^{\circ}\text{C} + 0.03^{\circ}\text{C} + 0.01^{\circ}\text{C} = 0.22^{\circ}\text{C}$
- Total Probable Error: $\sqrt{0.15^2 + 0.03^2 + 0.03^2 + 0.01^2} = 0.16^{\circ}\text{C}$

Temperature Effects Examples (Foundation fieldbus devices)

When using a Pt 100 ($\alpha = 0.00385$) sensor input at 30 °C span at 30 °C ambient temperature:

- Digital Temperature Effects: $0.003^{\circ}\text{C} \times (30 - 20) = 0.03^{\circ}\text{C}$
- D/A Effects: No D/A effects apply
- Worst Case Error: Digital + Digital Temperature Effects = $0.15^{\circ}\text{C} + 0.03^{\circ}\text{C} = 0.18^{\circ}\text{C}$
- Total Probable Error: $\sqrt{0.15^2 + 0.03^2} = 0.153^{\circ}\text{C}$

DIMENSIONAL DRAWINGS

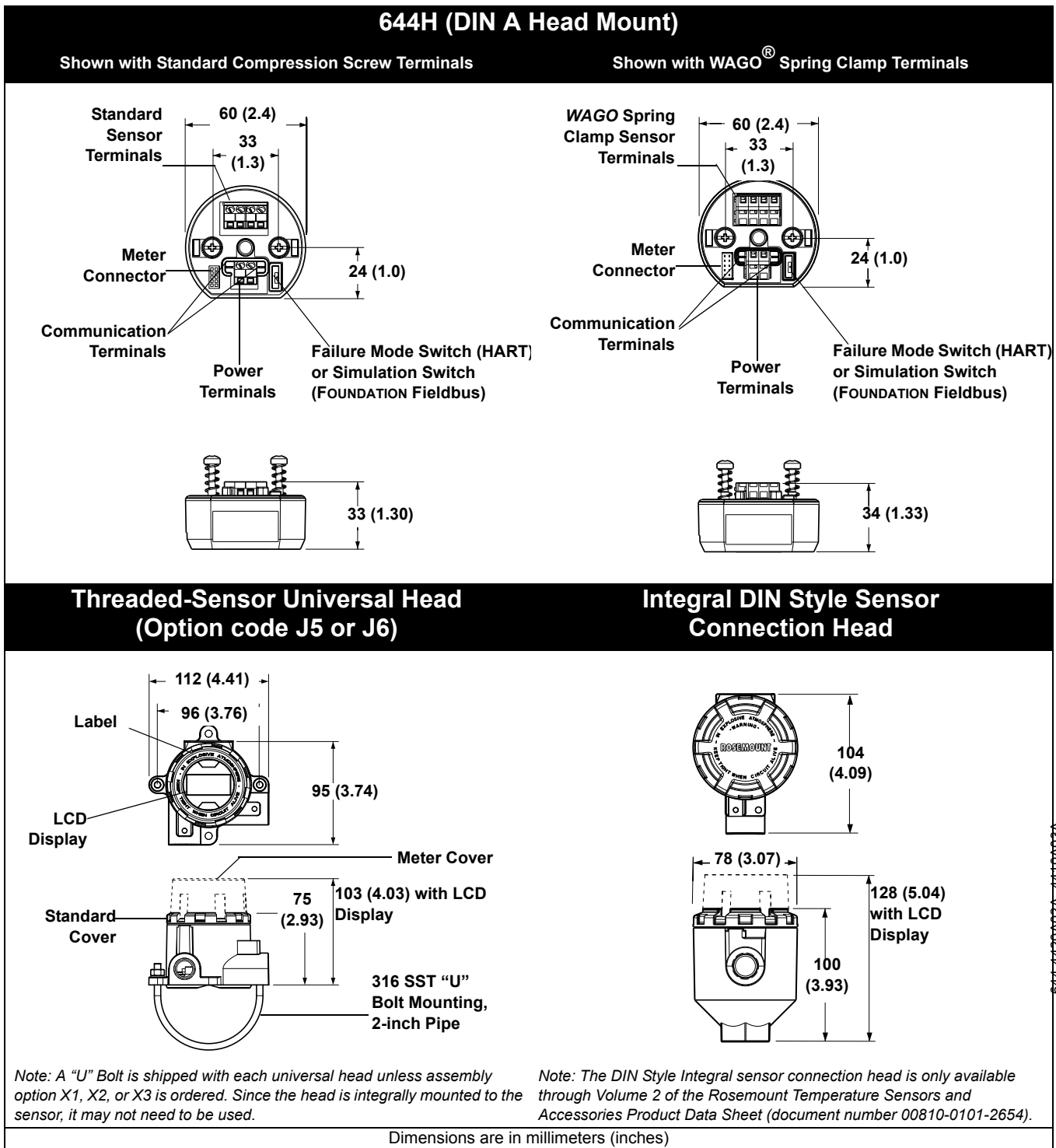

644-4420A02A, 44T0A03A

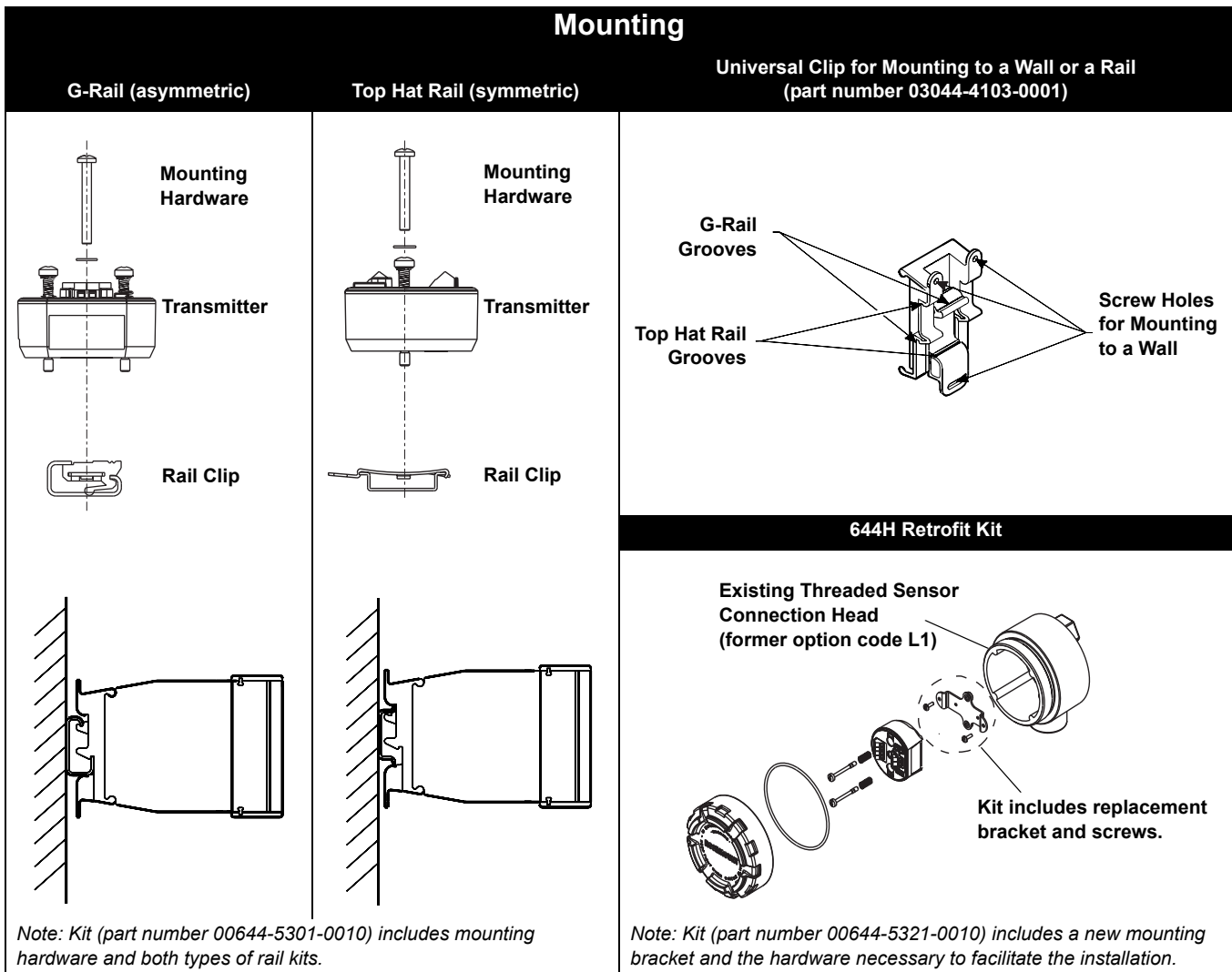
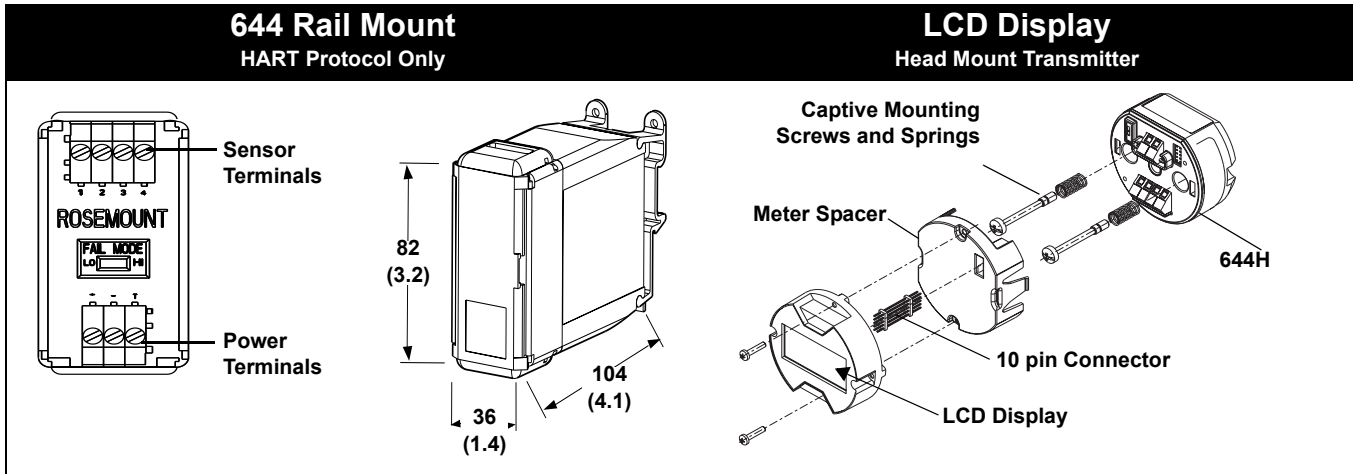

3044-4001A01B; 644-5302B01A; D02A

3044-0000C01B; D01B; 644-1041B02B; G02E

ORDERING INFORMATION

● = Available
– = Not Available

Model	Product Description				
644	Smart Temperature Transmitter				
Code	Transmitter Type				
H	Head Mount				
R	Rail Mount				
Code	Output	Head		Rail	
A	4–20 mA with digital signal based on HART protocol	●		●	
F	Foundation fieldbus digital signal (includes 2 AI function blocks and Backup Link Active Scheduler)	●		–	
Code	Product Certifications	A	F	A	F
Hazardous Locations Certificates (consult factory for availability)					
NA	No approval	●	●	●	–
E5	FM Explosion–Proof	●	●	–	–
I5 ⁽¹⁾	FM Intrinsic Safety (includes standard I.S. and FISCO for Fieldbus units)	●	●	●	–
K5 ⁽¹⁾	FM Intrinsic Safety and Explosion–Proof combination (includes standard I.S. and FISCO for Fieldbus units)	●	●	–	–
I6 ⁽¹⁾	CSA Intrinsic Safety (includes standard I.S. and FISCO for Fieldbus units)	●	●	●	–
K6 ⁽¹⁾	CSA Intrinsic Safety and Explosion–Proof combination (includes standard I.S. and FISCO for Fieldbus units)	●	●	–	–
E1	CENELEC ATEX Flame–Proof	●	●	–	–
N1	CENELEC ATEX Type n	●	●	–	–
NC	CENELEC ATEX Type n Component	●	●	●	–
ND	CENELEC ATEX Dust Ignition–Proof	●	●	–	–
I1 ⁽¹⁾	CENELEC ATEX Intrinsic Safety (includes standard I.S. and FISCO for Fieldbus units)	●	●	●	–
E7	SAA Flame–Proof	●	●	–	–
I7 ⁽²⁾⁽¹⁾	SAA Intrinsic Safety (includes standard I.S. and FISCO for Fieldbus units)	●	●	●	–
N7 ⁽²⁾	SAA Type n	●	●	–	–
I2 ⁽²⁾	CEPEL Intrinsic Safety	●	●	–	–
E4 ⁽²⁾	JIS Explosion–Proof	●	●	–	–
I4 ⁽²⁾	JIS Intrinsic Safety	●	●	●	–
Code	Options	A	F	A	F
Plant Web Software Functionality					
A01	Regulatory Control Suite – 1 PID Block	–	●	–	–
Assembly					
XA	Sensor specified separately and assembled to transmitter	●	●	–	–
Local Display (644H only)					
M5	LCD Display	●	●	–	–
Enclosure					
J5	Universal Head (junction box), aluminum alloy with 50.8 mm (2-in.) 316 SST pipe bracket (M20 entries)	●	●	–	–
J6	Universal Head (junction box), aluminum alloy with 50.8 mm (2-in.) 316 SST pipe bracket (1/2–14 NPT entries)	●	●	–	–
S1	Connection Head, Polished Stainless Steel (1/2–14 NPT entries)	●	●	–	–
S2	Connection Head, Polished Stainless Steel (1/2–14 NPSM entries)	●	●	–	–
S3	Connection Head, Polished Stainless Steel (M20 x 1.5 conduit and entries)	●	●	–	–
S4	Connection Head, Polished Stainless Steel (M20 x 1.5 conduit entries, M24 x 1.5 head entry)	●	●	–	–

● = Available
– = Not Available

		Head		Rail	
		A	F	A	F
Configuration Options					
C1	Factory configuration date, descriptor, and message fields (Configuration Data Sheet required).	●	●	●	–
C2	Transmitter-sensor matching, trim to specific Rosemount RTD calibration schedule (CVD constants)	●	●	●	–
A1	Analog output levels compliant with NAMUR-recommendations NE 43: June 1997: high alarm configuration	●	–	●	–
CN	Analog output levels compliant with NAMUR-recommendations NE 43: June 1997: low alarm configuration	●	–	●	–
C8	Low Alarm (standard Rosemount alarm and saturation values)	●	–	●	–
F6	60 Hz line voltage filter	●	●	●	–
Calibration Option					
C4	5-point calibration. Use option code Q4 to generate a calibration certificate	●	●	●	–
Q4	Calibration certificate. 3-Point calibration with certificate	●	●	●	–
Accessory Options (644 only)					
G1	External ground lug assembly ⁽³⁾ (see “External Ground Screw Assembly” on page A-14)	●	●	–	–
G2	Cable gland ⁽⁴⁾	●	●	–	–
G3	Cover chain. Only available with enclosure option codes J5 or J6. Not available with LCD Display option code M5.	●	●	–	–
G5	WAGO spring clamp terminals	●	●	–	–

Typical Rail Mount Model Number: 644 R A I5
Typical Head Mount Model Number: 644 H F I5 A01

- (1) When IS approval is ordered on a Foundation fieldbus, both standard IS and FISCO IS approvals apply. The device label is marked appropriately.
- (2) Consult factory for availability.
- (3) Only available with Enclosure option code J5 or J6. For ATEX approved units the Ground Lug Assembly is included. It is not necessary to include code G1 for units with ATEX approvals.
- (4) Only available with Enclosure option code J5.

TABLE 4. Transmitter Accessories

Part Description	Part Number
Aluminum alloy Universal Head, standard cover—M20 entries	00644-4420-0002
Aluminum alloy Universal Head, meter cover—M20 entries	00644-4420-0102
Aluminum alloy Universal Head, standard cover— ¹ / ₂ -14 NPT entries	00644-4420-0001
Aluminum alloy Universal Head, meter cover— ¹ / ₂ -14 NPT entries	00644-4420-0101
LCD Display (includes meter and meter spacer assembly)	00644-4430-0002
LCD Display kit (includes meter and meter spacer assembly, and meter cover)	00644-4430-0001
Ground screw assembly kit	00644-4431-0001
Kit, Hardware for mounting a 644H to a DIN rail (includes clips for symmetrical and asymmetrical rails)	00644-5301-0010
Kit, Hardware for retrofitting a 644H in an existing threaded sensor connection head (former option code L1)	00644-5321-0010
Kit, 316 U-Bolt for Universal Housing	00644-4423-0001
Blank transmitter configuration labels (sheet of 48)	00644-5154-0001
Universal clip for rail or wall mount	03044-4103-0001
24 Inches of symmetric (top hat) rail	03044-4200-0001
24 Inches of asymmetric (G) Rail	03044-4201-0001
Ground clamp for symmetric or asymmetric rail	03044-4202-0001
End clamp for symmetric or asymmetric rail	03044-4203-0001
Snap rings kit (used for assembly to a DIN sensor – quantity 12)	00644-4432-0001

ADDITIONAL INFORMATION

Tagging

Hardware

- No charge
- Tagged in accordance with customer requirements
- Tags are adhesive labels
- Permanently attached to transmitter
- Character height is $\frac{1}{16}$ -in (1.6 mm)

Software

- No charge
- The transmitter can store up to 30 characters. If no characters are specified, the first 8 characters of the hardware tag are the default.

Considerations

Special Mounting Considerations

See “Mounting” on page A-11 for the special hardware that is available to:

- Mount a 644H to a DIN rail.
- Retrofit a new 644H to replace an existing 644H transmitter in an existing threaded sensor connection head.

External Ground Screw Assembly

Specifying option code G1 to order the external ground screw assembly. It is not necessary to order option code G1 for those approvals that include the ground screw assembly. The table below identifies which approval options include the external ground screw assembly.

Approval Type	External Ground Screw Assembly Included?
E5, K5, I5, I6, K6, NC, NA	No—Order option code G1
N1, E1, ND, I1, E7, N7, I7, I4, and E4	Yes

Configuration

Transmitter Configuration

The transmitter is available with standard configuration setting for either HART (see “Standard HART Configuration”) or FOUNDATION fieldbus (see “Standard Foundation Fieldbus Configuration”). The configuration settings and block configuration may be changed in the field with the Fisher-Rosemount Systems DeltaV®, with AMSinside, or other FOUNDATION fieldbus host or configuration tool.

Custom Configuration

Custom configurations are to be specified when ordering. This configuration must be the same for all sensors. The following table lists the necessary requirements to specify a custom configuration.

Option Code	Requirements/ Specification	
C1: Factory Configuration Data (CDS required)	Date: day/month/year Descriptor: 16 alphanumeric characters Message: 32 alphanumeric character Analog Output: Alarm and saturation levels	
C2: Transmitter – Sensor Matching	The transmitters are designed to accept Callendar-Van Dusen constants from a calibrated RTD. Using these constants, the transmitter generates a custom curve to match the sensor-specific curve. Specify a Series 65, 65, or 78 RTD sensor on the order with a special characterization curve (V or X8Q4 option). These constants will be programmed into the transmitter with this option	
HART only	A1: NAMUR-Compliant, High Alarm	High Alarm = 21.5 mA Upscale Saturation = 20.5 mA
	CN: NAMUR-Compliant, Low Alarm	Low Alarm = 3.6 mA Downscale Saturation = 3.8 mA
C4: Five Point Calibration	Will include 5-point calibration at 0, 25, 50, 75, and 100% analog and digital output points. Use with Calibration Certificate Q4.	
F6: 60 Hz Line Filter	Calibrated to a 60 Hz line voltage filter instead of 50 Hz filter	

Standard HART Configuration

Unless specified, the transmitter will be shipped as follows:

Sensor Type	RTD, Pt 100 ($\alpha=0.00385$, 4-wire)
4 mA Value	0 °C
20 mA Value	100 °C
Damping	5 seconds
Output	Linear with temperature
Failure/Saturation Modes	High (21.75 mA) / Upscale (20.5 mA)
Line Voltage Filter	50 Hz
Tag	Configuration Data Sheet requires

Standard FOUNDATION Fieldbus Configuration

Unless otherwise specified, the transmitter will be shipped as follows for all sensors:

Sensor Type: 4-wire Pt 100 ($\alpha = 0.00385$) RTD

Damping: 5 seconds

Units of Measurement: °C

Line Voltage Filter: 50 Hz

Software Tag: See "Tagging"

Function Blocks Tags:

- Resource Block: RB
- Transducer Block: TB
- LCD Block: LCD
- Analog Input Blocks: AI1, AI2

Alarm Range: 0

Alarm Limits of AI1 and AI2:

- HI-HI: 100 °C (212 °F)
- HI: 95 °C (203 °F)
- LO: 5 °C (41 °F)
- LO-LO: 0 °C (32 °F)

Local Display (when installed): Engineering Units of Temperature

Standard Block Configuration

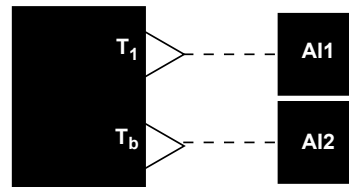

Note:
 T_1 = Sensor Temperature
 T_b = Terminal Temperature

Final Station

AI Blocks are scheduled for 1 second. AI Blocks are linked as shown above.

STAINLESS STEEL HOUSING

The Stainless Steel Housing is ideal for Biotechnology, Pharmaceutical Industries, and Sanitary Applications

Weight

Option Code	Standard Cover	Meter Cover
S1	840 g (27 oz)	995 g (32 oz)
S2	840 g (27 oz)	995 g (32 oz)
S3	840 g (27 oz)	995 g (32 oz)
S4	840 g (27 oz)	995 g (32 oz)

Enclosure Rating

NEMA 4X, IP66, and IP68

Materials of Construction

Housing and Standard Meter Cover

- 316L SST

Cover O-Ring

- Buna-N

LCD Display Cover

- 316L SST
- Glass

Surface

Surface finish is polished to 32 RMA. Laser etched product marking on housing and standard covers.

Dimensional Drawings

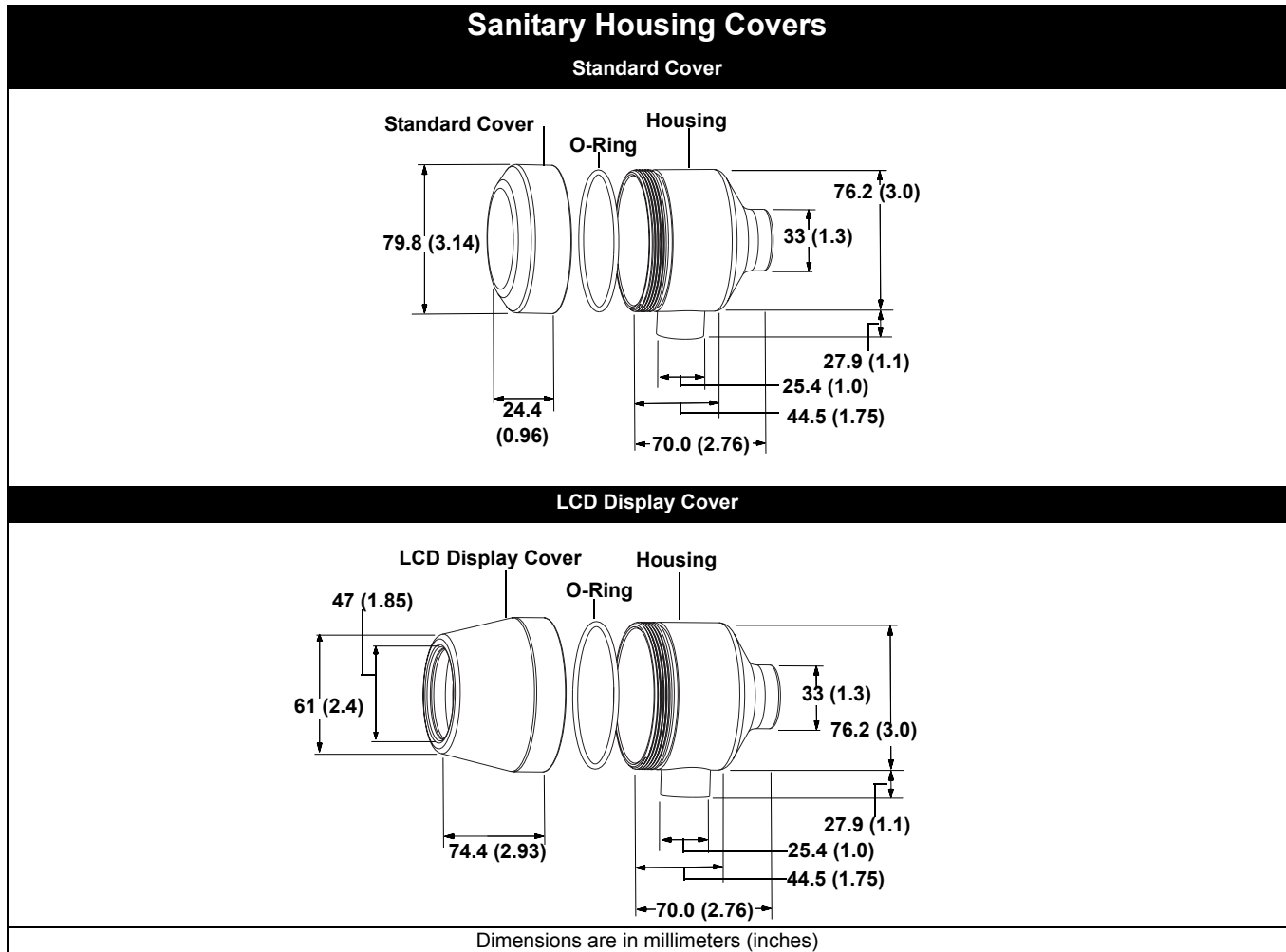

Appendix B Product Certifications

Approved Manufacturing Locations	page B-1
European Union Directive Information	page B-1
Hazardous Locations Certificates	page B-2
Installation Drawings	page B-8

APPROVED MANUFACTURING LOCATIONS

Emerson Process Management Rosemount Division. – Chanhassen,
Minnesota, USA
Rosemount Temperature GmbH – Germany
Emerson Process Management Asia Pacific – Singapore

EUROPEAN UNION DIRECTIVE INFORMATION

The EC declaration of conformity for all applicable European directives for this product can be found on the Rosemount website at www.rosemount.com. A hard copy may be obtained by contacting our local sales representative.

ATEX Directive (94/9/EC)

Rosemount Inc. complies with the ATEX Directive.

Electro Magnetic Compatibility (EMC) (89/336/EEC)

644H and 644R – EN 50081-1: 1992; EN 50082-2:1995;
EN 61326-1:1997 +A1

HAZARDOUS LOCATIONS CERTIFICATES

Rosemount 644 with FOUNDATION Fieldbus

The product certifications for the Rosemount 644 with FOUNDATION fieldbus are pending. Consult the factory for additional information.

North American Certifications

Factory Mutual (FM) Approvals

- I5 FM Intrinsic Safety
Intrinsically Safe (Entity) / FISCO for use in Class I/II/III, Division 1, Groups A, B, C, D, E, F, and G; when installed per control drawing 00644-2075.
Temperature Code: T4A ($T_{amb} = -50\text{ °C to }40\text{ °C}$).

Nonincendive for use in Class I, Division 2, Groups A, B, C, and D.
Temperature Code: T6 ($T_{amb} = -50\text{ °C to }70\text{ °C}$);
T5 ($T_{amb} = -50\text{ °C to }85\text{ °C}$)
- E5 FM Explosion-Proof:
Explosion-Proof for Class I, Division 1, Groups B, C, and D. Dust Ignition Proof for Class II/III, Division 1, Groups E, F, G when installed per Rosemount Drawing 00644-1049.
Temperature Code: T5 ($T_{amb} = -50\text{ °C to }85\text{ °C}$)

Canadian Standards Association (CSA) Approvals

- I6 CSA Intrinsic Safety
Intrinsically Safe for Class I, Division 1, Groups A,B,C, and D when installed in accordance with Rosemount drawing 00644-2076.
Temperature Code: T4 ($T_{amb} = -50\text{ °C to }60\text{ °C}$)
- K6 CSA Intrinsic Safety, Explosion-Proof, and Non-incendive.
Combination of I6 and Explosion-proof for Class I, Division 1, Groups B, C, and D; Dust-ignition proof for Class II, Division 1, Groups E, F, and G; Class III, Division 1 hazardous locations, when installed in accordance with Rosemount drawing 00644-1059.
Temperature Code: T4 ($T_{amb} = -50\text{ °C to }85\text{ °C}$)
Suitable for Class I, Division 2, Groups B, C, and D when installed in a suitable enclosure.
Temperature Code: Temperature Code: T4 ($T_{amb} = -50\text{ °C to }60\text{ °C}$);
T5 ($T_{amb} = -50\text{ °C to }85\text{ °C}$)

NOTE

K6 is only available with 644H option code J6.

European Certifications

ATEX Approvals

- E1 ATEX Flame Proof
 Certificate Number: KEMA99ATEX8715
 ATEX Marking: Ⓢ II 2 G
 ⒸⒺ 1180
 EEx d IIC T6 ($-40\text{ °C} \leq T_{amb} \leq 65\text{ °C}$)
 $U_i = 55\text{ Vdc}$
 $I_i = 24.0\text{ mA}$
- I1 ATEX Intrinsic Safety/FISCO
 Certificate Number: Baseefa03ATEX0499X
 ATEX Marking: Ⓢ II 1 G
 ⒸⒺ 1180
 EEx ia IIC T4 ($-50\text{ °C} \leq T_{amb} \leq 60\text{ °C}$)

TABLE 1. Entity Parameters

I.S. Power/Loop	FISCO	Sensor
Intrinsic Safety		
$U_i = 30\text{ V}$	$U_i = 17.5\text{ V}$	$U_i = 13.9\text{ V}$
$I_i = 300\text{ mA}$	$I_i = 380\text{ mA}$	$I_i = 23\text{ mA}$
$P_i = 1.3\text{ W}$	$P_i = 5.32\text{ W}$	$P_i = 79\text{ mW}$
$C_i = 2.1\text{ nF}$	$C_i = 2.1\text{ nF}$	$C_i = 7.7\text{ nF}$
$L_i = 0$	$L_i = 0$	$L_i = 0$

Special Conditions for Safe Use (X):

The apparatus must be installed in an enclosure which affords it a degree of protection of at least IP20. Non-metallic enclosures must have a surface resistance of less than 1Ω ., light alloy or zirconium enclosures must be protected from impact and friction when installed.

- N1 ATEX Type n
 Certificate Number: BAS00ATEX3145
 ATEX Marking: Ⓢ II 3 G
 EEx nL IIC T5($-40\text{ °C} \leq T_{amb} \leq 70\text{ °C}$)
 Max Input Voltage: $U_i = 45\text{ V dc}$
- NC ATEX Type n Component
 Certificate Number: BAS99ATEX3084U
 ATEX Marking: Ⓢ II 3 G
 EEx nL IIC T5 ($-40\text{ °C} \leq T_{amb} \leq 70\text{ °C}$)

Special Conditions for Safe Use (X):

The equipment must be installed in an enclosure meeting the requirements of IP54 and the requirements of the impact tests described in EN 50021.

- ND ATEX Dust Ignition-Proof
 Certificate Number: KEMA99ATEX8715
 ATEX Marking: Ⓢ II 1 D
 ⒸⒺ 1180
 $T_{95\text{ °C}} (-40\text{ °C} < T_{amb} < +85\text{ °C})$
 IP66
 Max Input: $U_i = 55\text{ Vdc}$
 $I_i = 24\text{ mA}$

Australian Certifications

Standard Australia Quality Assurance Service (SAA) Approvals

- I7 SAA Intrinsic Safety
Certificate Number: Consult factory
Ex ia IIC
- E7 SAA Explosion-Proof
Certificate Number: AUS Ex3706X
Ex d IIC T6
Temperature Code: T6 ($T_{amb} = -40^{\circ}\text{C}$ to 65°C)

NOTE

Flame-Proof certification is only available as a complete assembly with Rosemount universal head – option codes J5 or J6.

- N7 SAA Type n
Certificate Number: Consult factory
Ex n

Brazilian Certifications

Centro de Pesquisas de Energia Eletrica (CEPEL) Approval

- I2 CEPEL Intrinsic Safety

Japanese Certifications

Japanese Industrial Standard (JIS) Approvals

- I4 JIS Intrinsic Safety
- E4 JIS Explosion Proof

Combination Approvals

- K5 Combination of I5 and E5.

NOTE

K5 is only available with 644H option code J6.

Rosemount 644 with HART

North American Certifications

Factory Mutual (FM) Approvals

- I5 FM Intrinsic Safety and Non-incendive:
 Intrinsically Safe for Class I/II/III, Division 1, Groups A, B, C, D, E, F, and G.
 Non-incendive for Class I, Division 2, Groups A, B, C, and D. Intrinsically Safe and non-incendive when installed in accordance with Rosemount drawing 00644-0009.

TABLE 2. Temperature Code

Pi	Temperature Code
0.67 W	T5 (T _{amb} = - 50 °C to 50 °C)
0.67 W	T6 (T _{amb} = - 50 °C to 40 °C)
1.0 W	T4 (T _{amb} = - 50 °C to 80 °C)
1.0 W	T5 (T _{amb} = - 50 °C to 40 °C)

- E5 FM Explosion-Proof and Non-incendive:
 Explosion-Proof for Class I, Division 1, Groups B, C, and D. Dust Ignition Proof for Class II/III, Division 1, Groups E, F, G when installed per Rosemount Drawing 00644-1049. Non-incendive for Class 1, Division 2, Groups A, B, C, and D. Temperature Code: T5 (T_{amb} = -50 °C to 85 °C)
 Conduit seal not required for compliance with NEC501-5a(1).

NOTE

Approval E5 is only available with 644H option codes J5 and J6.

- K5 Combination of I5 and E5.

NOTE

K5 is only available with 644H option code J6.

Canadian Standards Association (CSA) Approvals

- I6 CSA Intrinsic Safety
 Intrinsically Safe for Class I, Division 1, Groups A, B, C, and D when installed in accordance with Rosemount drawing 00644-1064.

TABLE 3. Temperature Code

Pi	Temperature Code
0.67 W	T6 (T _{amb} = - 50 °C to 40 °C)
0.67 W	T5 (T _{amb} = - 50 °C to 60 °C)
1.0 W	T4 (T _{amb} = - 50 °C to 80 °C)

- K6 CSA Intrinsic Safety, Explosion-Proof, and Non-incendive.
 Combination of I6 and Explosion-proof for Class I, Division 1, Groups B, C, and D; Dust-ignition proof for Class II, Division 1, Groups E, F, and G; Class III, Division 1 hazardous locations, when installed in accordance with Rosemount drawing 00644-1059.
 Temperature Code: T4(T_{amb} = -50 °C to 85 °C)
 Suitable for Class I, Division 2, Groups B, C, and D when installed in a suitable enclosure.
 Temperature Code: T5 (T_{amb} = -50 °C to 85 °C).

NOTE

K6 is only available with 644H option code J6.

European Certifications

ATEX Approvals

- I1 ATEX Intrinsic Safety:
Certificate Number: BAS00ATEX1033X
ATEX Marking: Ⓢ II 1 G EEx ia IIC T4/T5/T6
CE 1180

TABLE 4. Temperature Code

Pi	Temperature Code
0.67 W	T6 (− 60 °C ≤ T _{amb} ≤ 40 °C)
0.67 W	T5 (− 60 °C ≤ T _{amb} ≤ 50 °C)
1.0 W	T5 (− 60 °C ≤ T _{amb} ≤ 40 °C)
1.0 W	T4 (− 60 °C ≤ T _{amb} ≤ 80 °C)

TABLE 5. Entity Parameters

Loop/Power	Sensor
U _i = 30 V	U _o = 13.6 V
I _i = 200 mA	I _o = 80 mA
P _i = 0.67 W or 1.0 W	P _o = 80 mW
C _i = 10 nF	C _i = 75 nF
L _i = 0	L _i = 0

Special Conditions for Safe Use (X):

The transmitter must be installed so that its external terminals and communication pins are protected to at least IP20. Non-metallic enclosures must have a surface resistance of less than 1GΩ. Light alloy or zirconium enclosures must be protected from impact and friction when installed.

- E1 ATEX Flame-Proof:
Certificate Number: KEMA99ATEX8715
ATEX Marking: Ⓢ II 2 G EEx d IIC T6
CE 1180
Temperature Code: T6 (−40°C ≤ T_{amb} ≤ 65°C)
Max Input: U_i=55Vdc
I_i = 24.0 mA
- N1 ATEX Type n:
Certificate Number: BAS00ATEX3145
ATEX Marking: Ⓢ II 3 G EEx nL IIC T5
Temperature Code: T5 (−40°C ≤ T_{amb} ≤ 70°C)
Max Input Voltage: U_i=45Vdc
- NC ATEX Type n Component:
Certificate Number: BAS99ATEX3084U
ATEX Marking: Ⓢ II 3 G EEx nL IIC T5
Temperature Code: T5 (−40°C ≤ T_{amb} ≤ 70°C)
Max Input Voltage: U_i=45Vdc

NOTE

The equipment must be installed in an enclosure meeting the requirements of IP54 and the requirements of the impact tests described in EN50021.

- ND ATEX Dust Ignition-Proof
 Certificate Number: KEMA99ATEX8715
 ATEX Marking: Ⓢ II 1 D
 cE 1180
 T95°C (-40°C < Tamb < +85°C)
 IP66
 Max Input: $U_i = 55 \text{ Vdc}$
 $I_i = 24.0 \text{ mA}$

Australian Certifications

Standard Australia Quality Assurance Service (SAA) Approvals

- E7 SAA Explosion-Proof
 Certificate Number: AUS Ex3706X
 Ex d IIC T6
 Temperature Code: T6 ($T_{amb} = -40^\circ\text{C}$ to 65°C)

NOTE

Flame-Proof certification is only available as a complete assembly with Rosemount universal head – option codes J5 or J6.

- I7 SAA Intrinsic Safety
 Certificate Number: AUS Ex 03.3877X
 Ex ia IIC
 Temperature Code: T5 ($T_{amb} = -60$ to 75°C)
 T6 ($T_{amb} = -60$ to 50°C)

TABLE 6. Input Entity Parameters

Loop / Power	Sensor
$U_i = 30 \text{ V dc}$	$U_o = 17.3 \text{ V}$
$I_i = 200 \text{ mA}$	$I_o = 247 \text{ mA}$
$P_i = 1.0 \text{ W}$	$P_o = 0.08 \text{ W}$
$C_i = 5.3 \text{ nF}$	$C_o = 0.70 \mu\text{F}$
$L_i = 0 \text{ mH}$	$L_o = 3.13 \text{ mH}$

Special Condition for Safe Use (X):

1. It is a condition of safe use that for Ex ia applications, the equipment is to be housed in an enclosure that provides an ingress protection rating of not less than IP20.
2. It is a condition of safe use that the installation shall be carried out in according with Rosemount drawing 00644-1044.
3. It is a condition of safe use that a user may fit an optional LCD indicator to 644H Temperature Transmitter certified in this certificate after installation subject to the conditions requirement of this certificate.

- N7 SAA Type n
 Certificate Number: AUS Ex 03.3877X
 Ex n IIC
 Temperature Code: T5 ($T_{amb} = -60$ to 75°C)
 T6 ($T_{amb} = -60$ to 50°C)

Special Condition for Safe Use (X):

1. It is a condition of safe use that for Ex n applications, the equipment is to be housed in an enclosure that provides an ingress protection rating of not less than IP54.

2. Input parameters for non-sparking protection model: Ex n
Input Parameters Power/Loop Terminals (Pins "+", "-", "T"):
Maximum Input Voltage $U_n = 55 \text{ V}$
Maximum Input Power $P_n = 1.3 \text{ W}$

Brazilian Certifications

Centro de Pesquisas de Energia Eletrica (CEPEL) Approval

I2 CEPEL Intrinsic Safety. Not available, consult factory

Russian Certifications

Gostandart

Tested and approved by the Russian Metrological Institute GOSTANDART.

Japanese Certifications

Japanese Industrial Standard (JIS) Approvals

E4 JIS Explosion-Proof

TABLE 7. Certificate and Description

Certificate	Description	Approval Group	Temp Code
C15744	644H with meter and no sensor	Ex d II C	T6
C15745	644H without meter and no sensor	Ex d II C	T6
C15910	644H without meter and with thermocouple	Ex d II B + H2	T4
C15911	644H with meter and thermocouple	Ex d II B + H2	T4
C15912	644H without meter and with RTD	Ex d II B + H2	T4
C15913	644H with meter and RTD	Ex d II B + H2	T4

INSTALLATION DRAWINGS

The installation guidelines presented by the drawings must be followed in order to maintain certified ratings for installed transmitters.

Rosemount Drawing 00644-1064, 1 Sheet,
Canadian Standards Association Intrinsic Safety Installation Drawing

Rosemount Drawing 00644-1059, 1 Sheet;
Canadian Standards Association Explosion-Proof Installation Drawing

Rosemount Drawing 00644-2076, 3 Sheets;
Canadian Standards Association 644 Fieldbus Intrinsic Safety/FISCO Installation Drawing

Rosemount Drawing 00644-0009, 2 Sheet
Factory Mutual Intrinsic Safety Installation Drawing

Rosemount Drawing 00644-1049, 1 Sheet;
Factory Mutual Explosion-proof Installation Drawing

Rosemount Drawing 00644-2075, 3 Sheets;
Factory Mutual 644 Fieldbus Intrinsic Safety/FISCO Installation Drawing

IMPORTANT

Once a device labeled with multiple approval types is installed, it should not be reinstalled using any of the other labeled approval types. To ensure this, the approval label should be permanently marked to distinguish the used from the unused approval type(s).

Figure B-1. CSA Intrinsic Safety Installation Drawing 00644-1064, Rev. AB

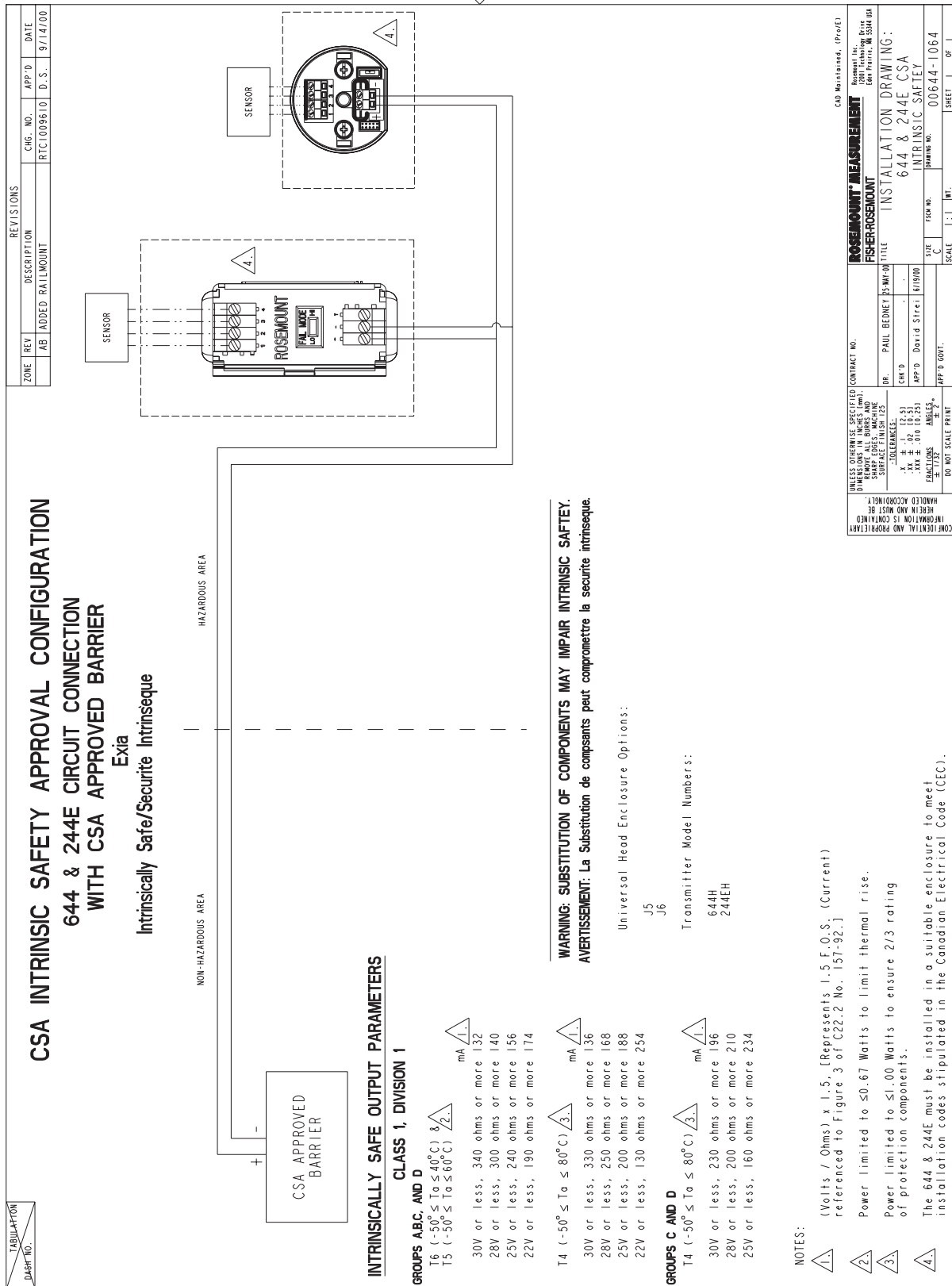

Figure B-2. CSA Explosion-Proof Installation Drawing 00644-1059, Rev. AF

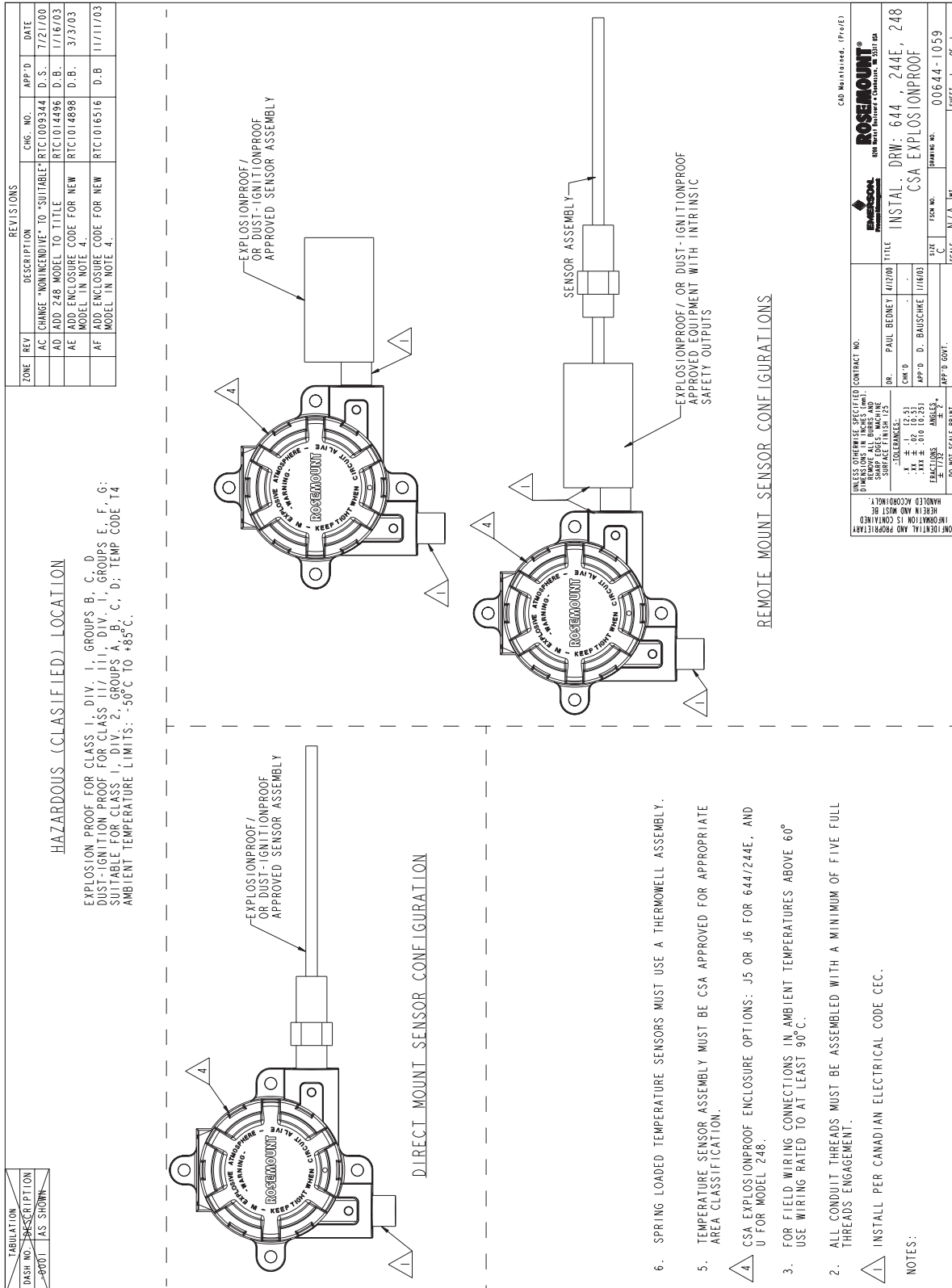
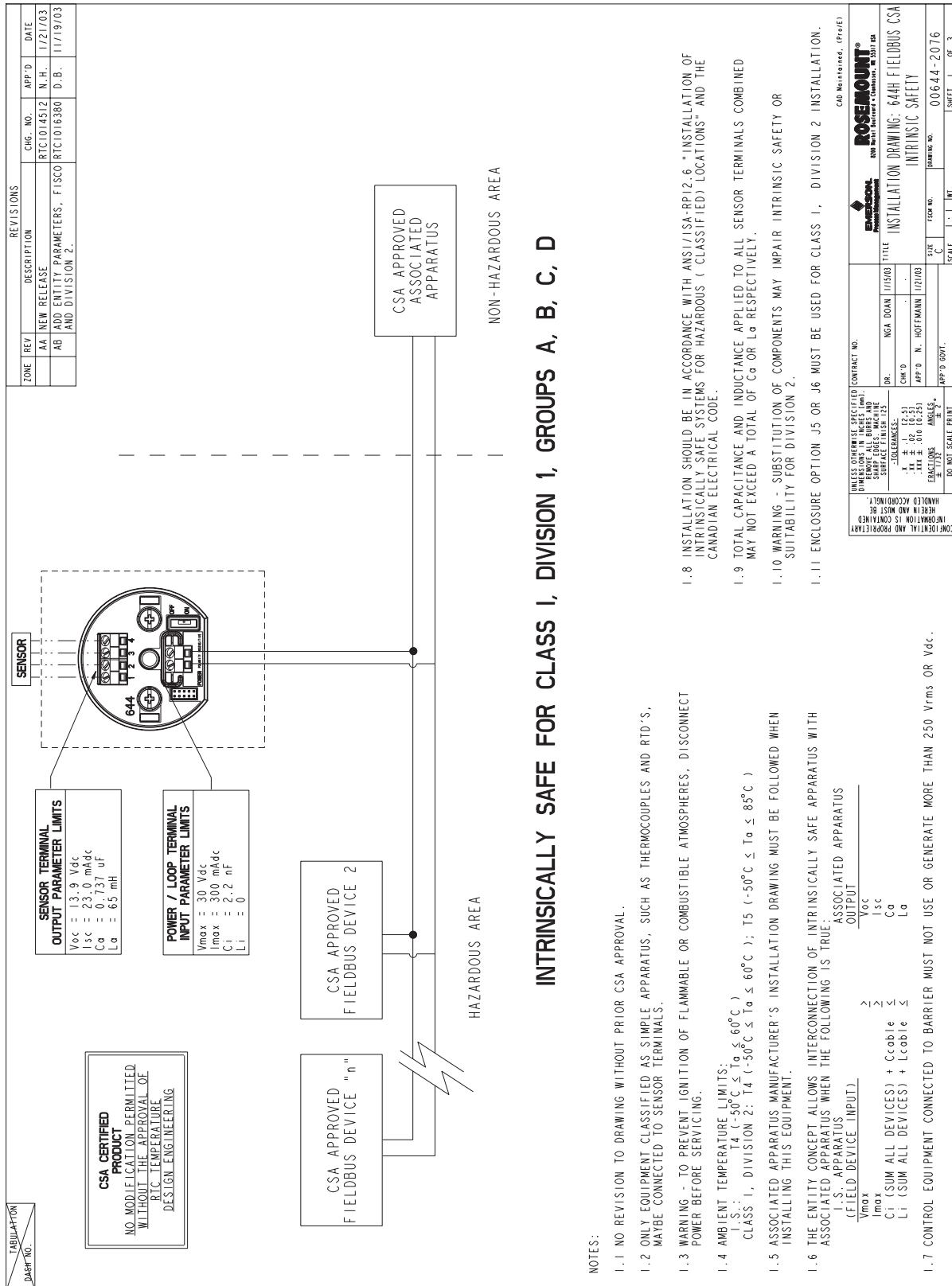
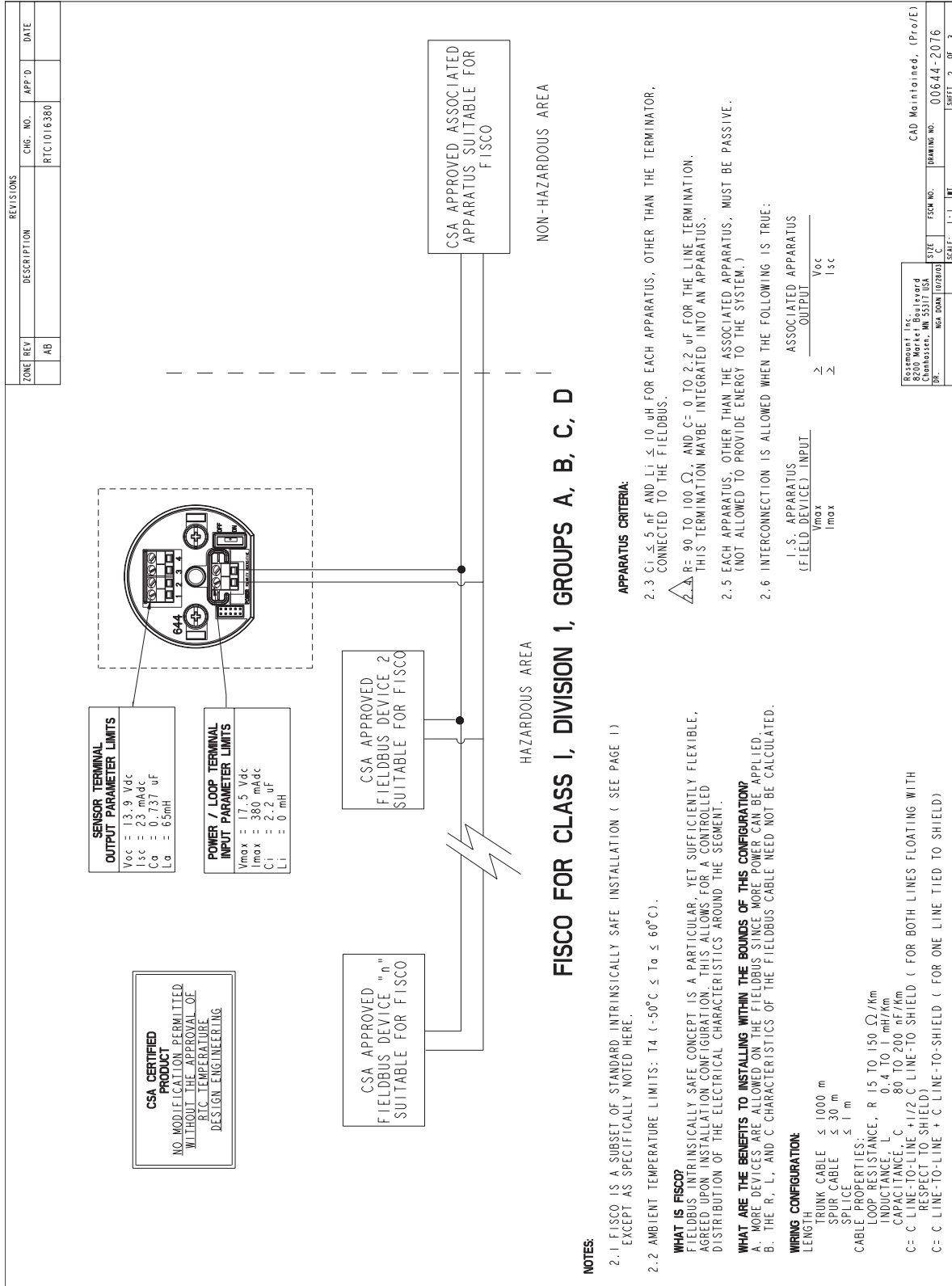

Figure B-3. CSA 644 Fieldbus Intrinsic Safety, FISCO Installation Drawing 00644-2076, Rev. AB Sheet 1 of 3



Sheet 2 of 3



Sheet 3 of 3

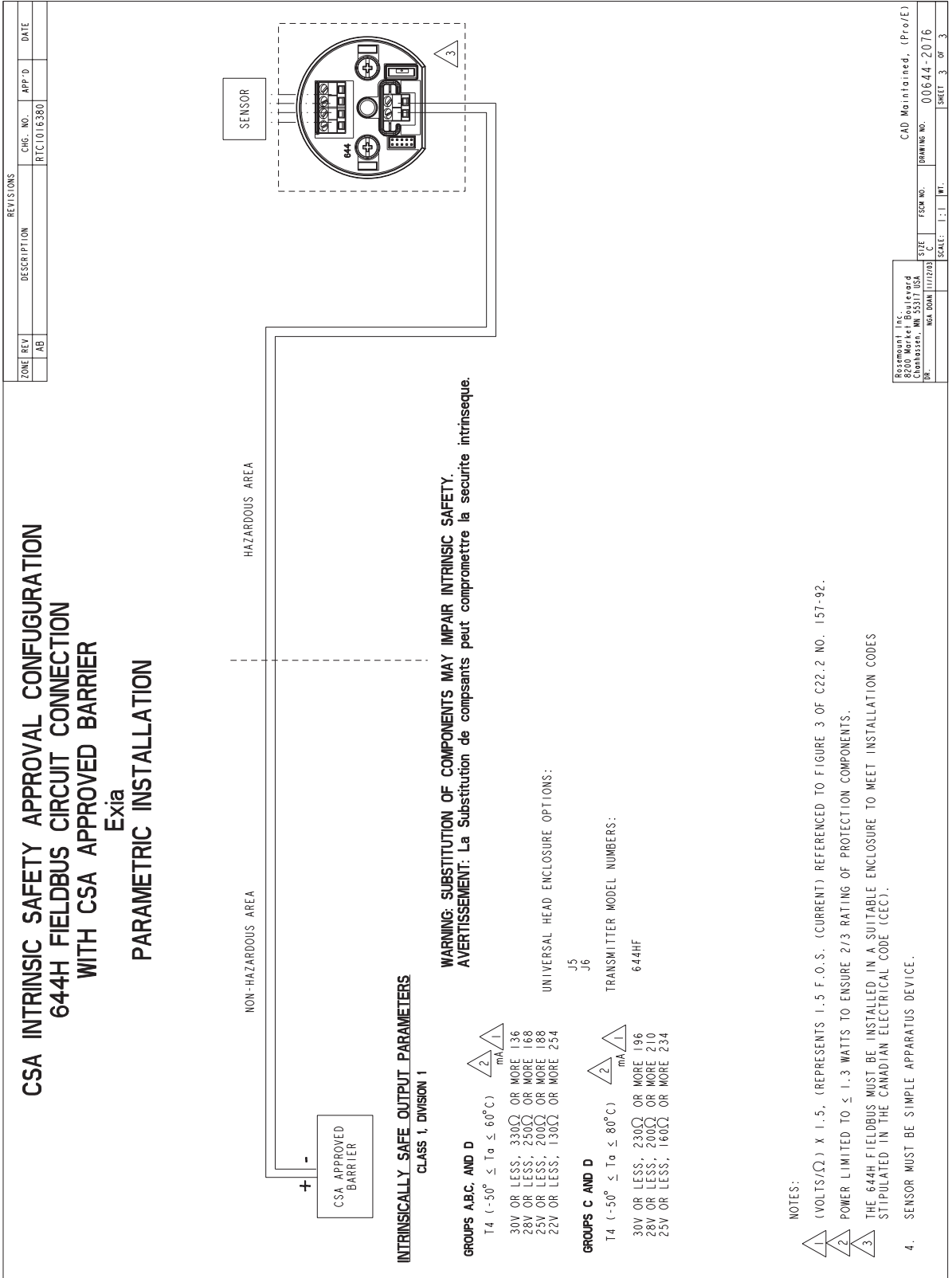

644-0009A01A

Figure B-4. FM Intrinsic Safety Installation Drawing 00644-0009, Rev. AD Sheet 1 of 2

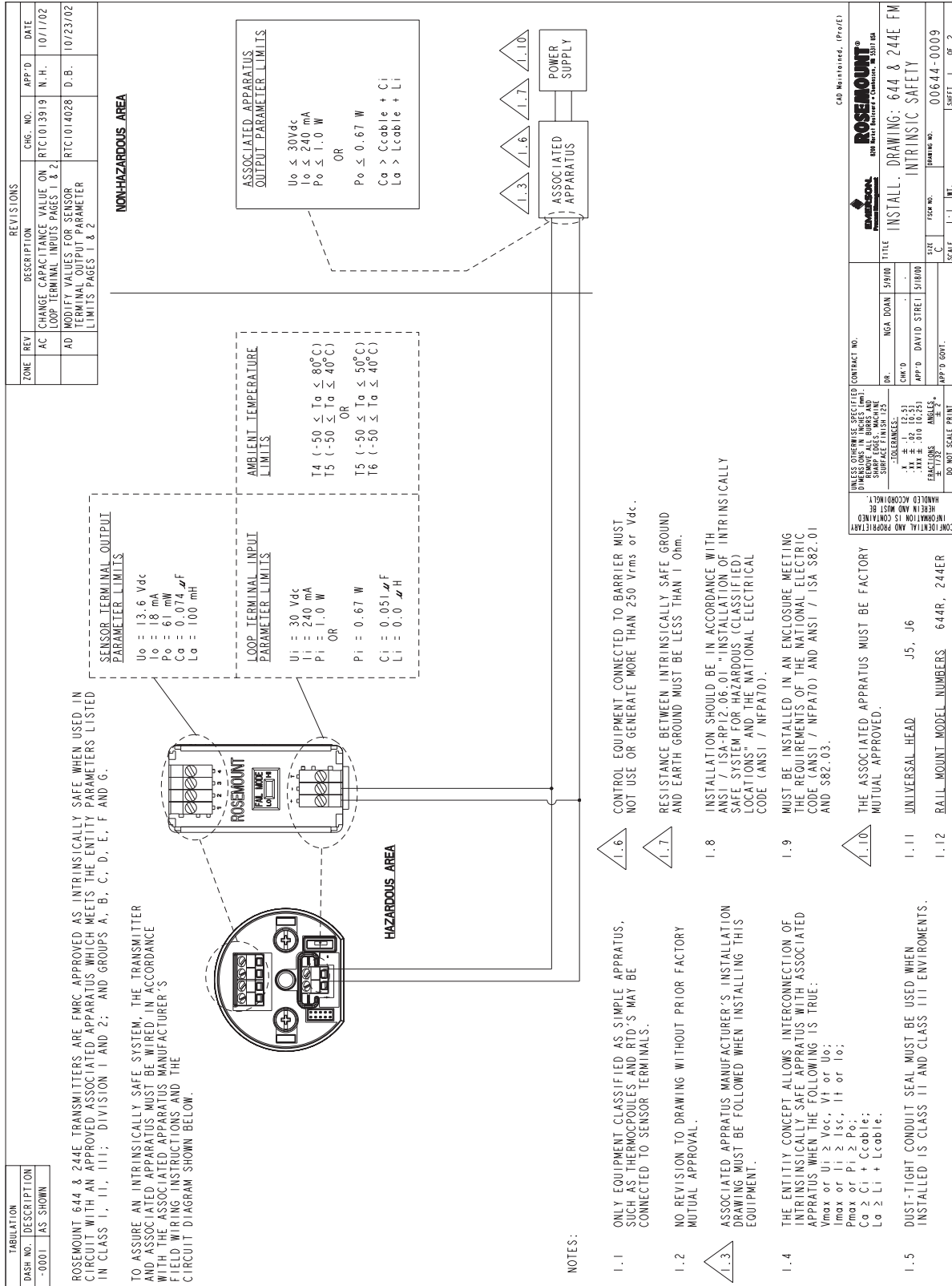

Sheet 2 of 2

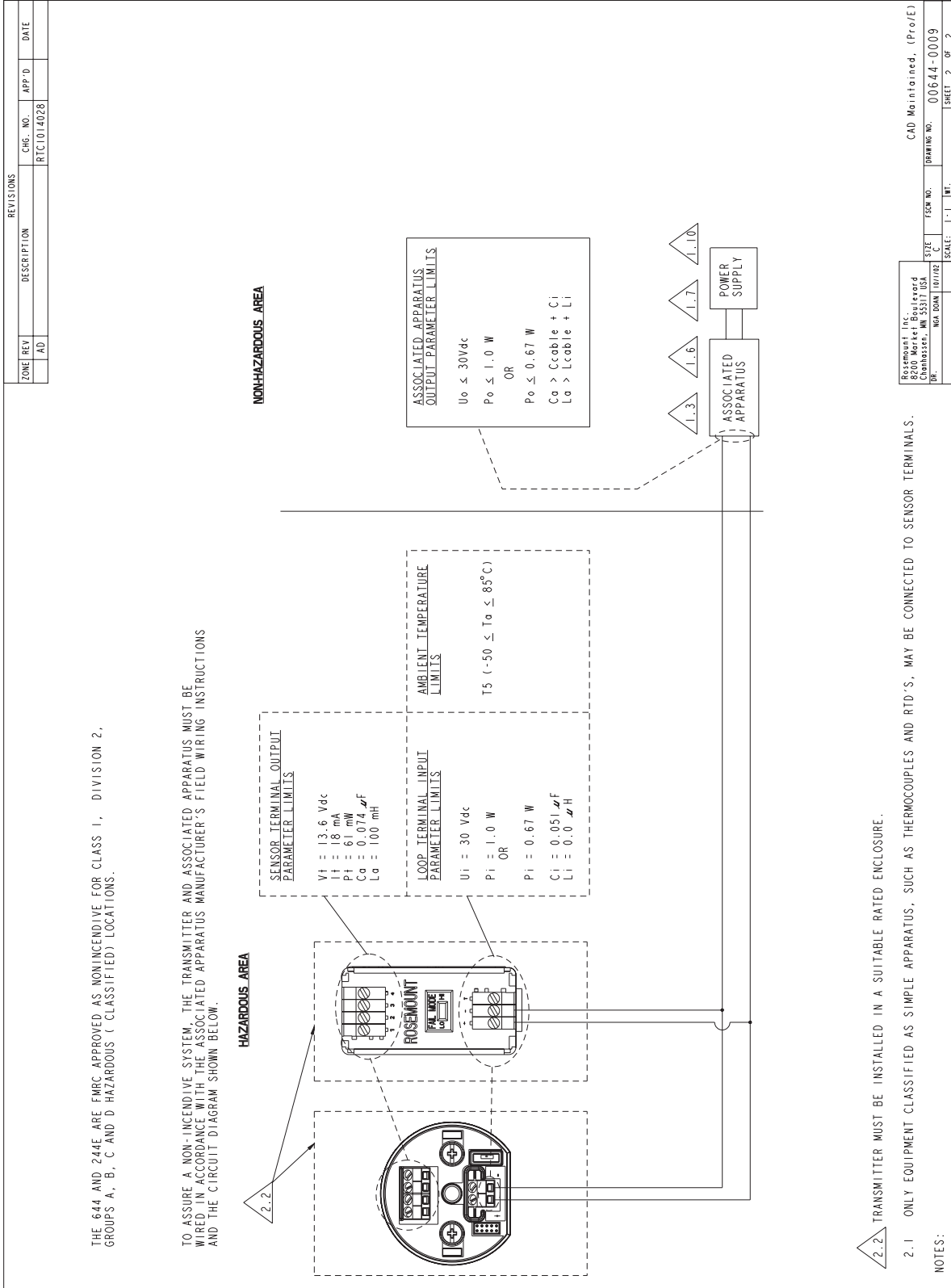

REVISIONS			
ZONE	REV	DESCRIPTION	DATE
	AD		

CHG. NO.	APP'D	DATE
RTCI014028		

Rosemount Inc. 8200 Market Boulevard Channahon, IL 63311 USA	SIZE C	FSCM NO.	DRAWING NO.	CAD Maintained. (Pro/E)
REP.	REP. DRAW	SCALE: 1:1	00644-0009	SHEET 2 OF 2

644-0009A01A

Figure B-5. FM Explosion-Proof Installation Drawing 00644-1049, Rev. AD

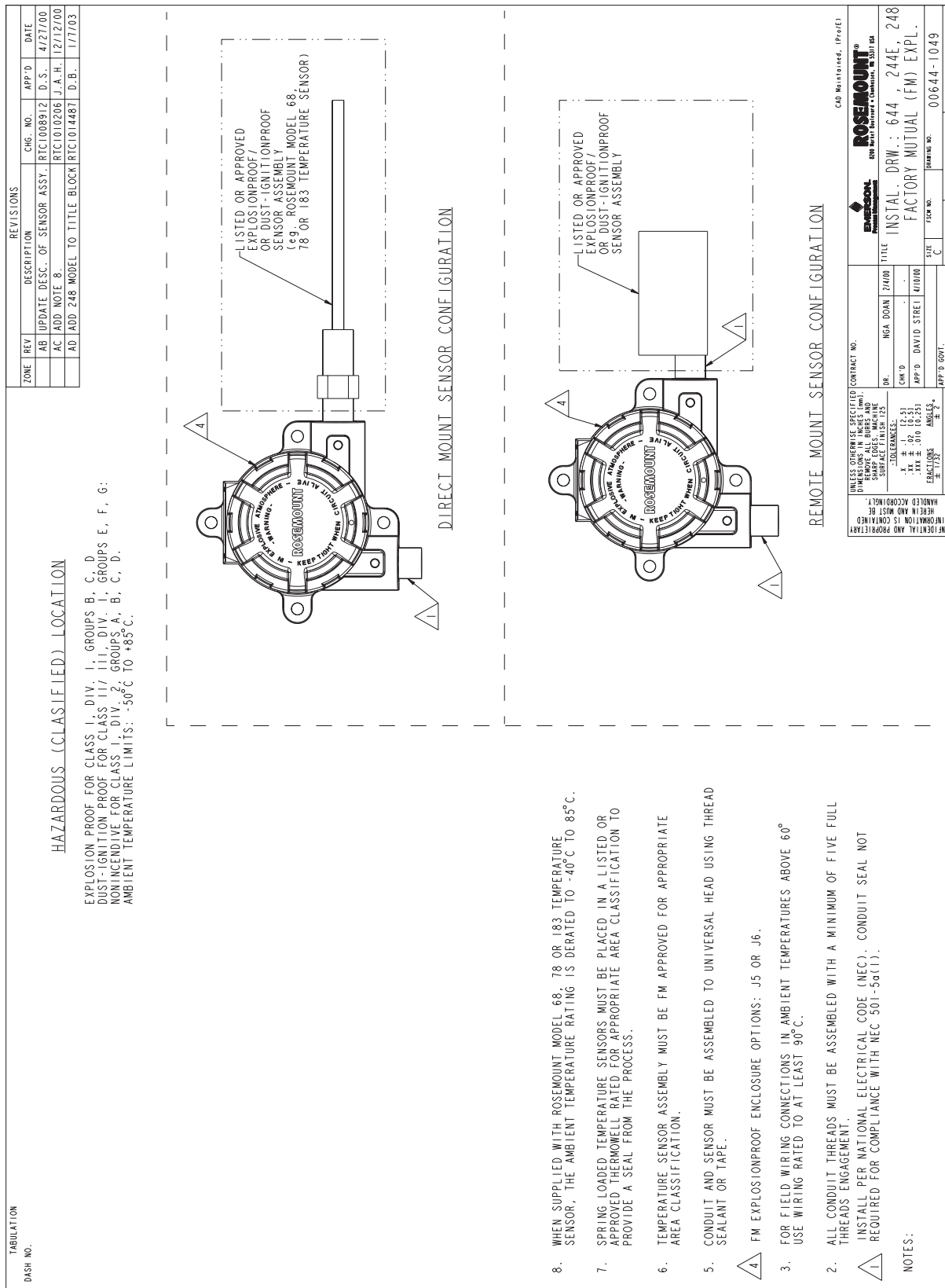
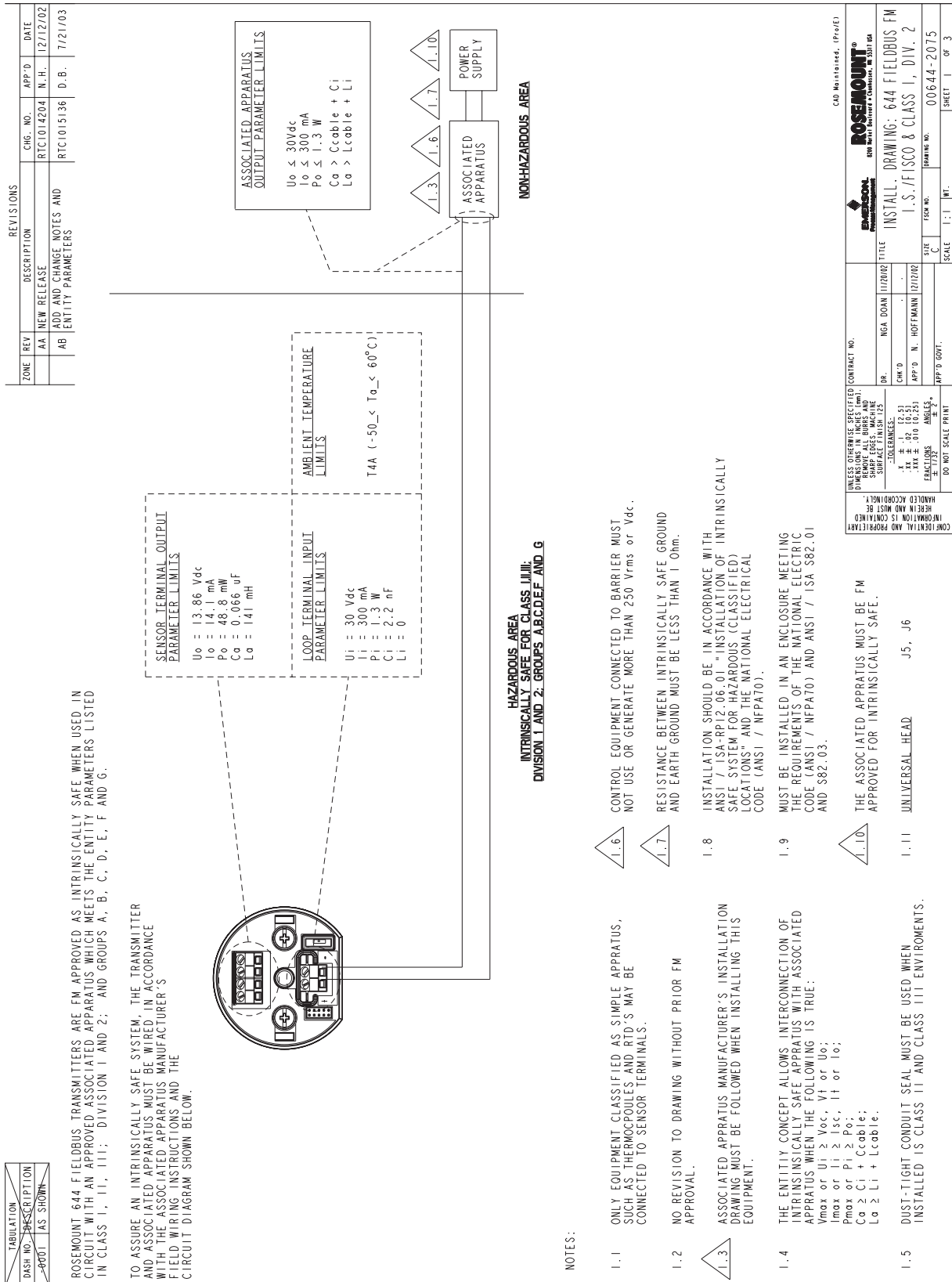
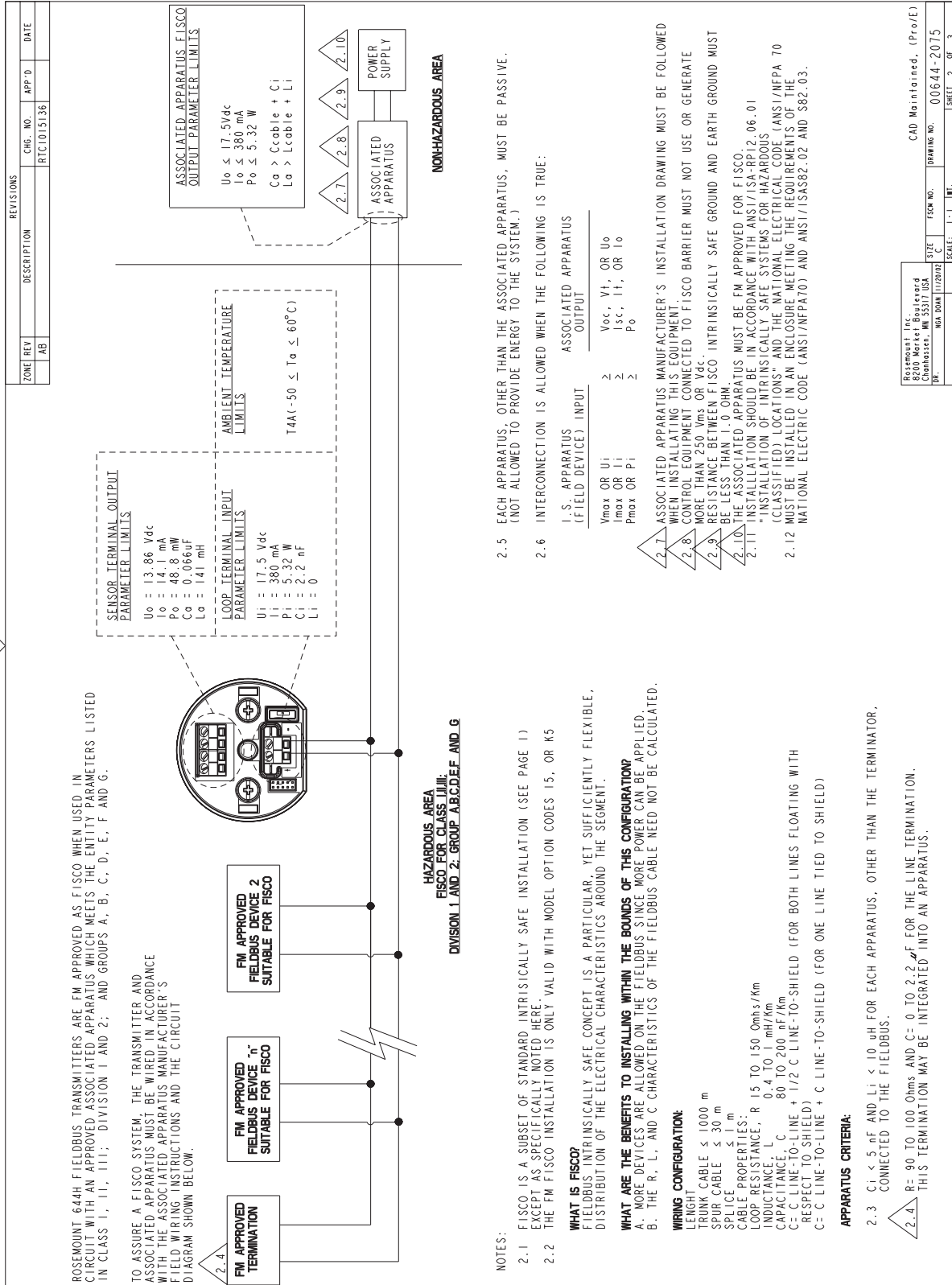

Figure B-6. FM 644 Fieldbus Intrinsic Safety and FISCO Installation Drawing 00644-2075, Rev. AB Sheet 1 of 3



Sheet 2 of 3



Sheet 3 of 3

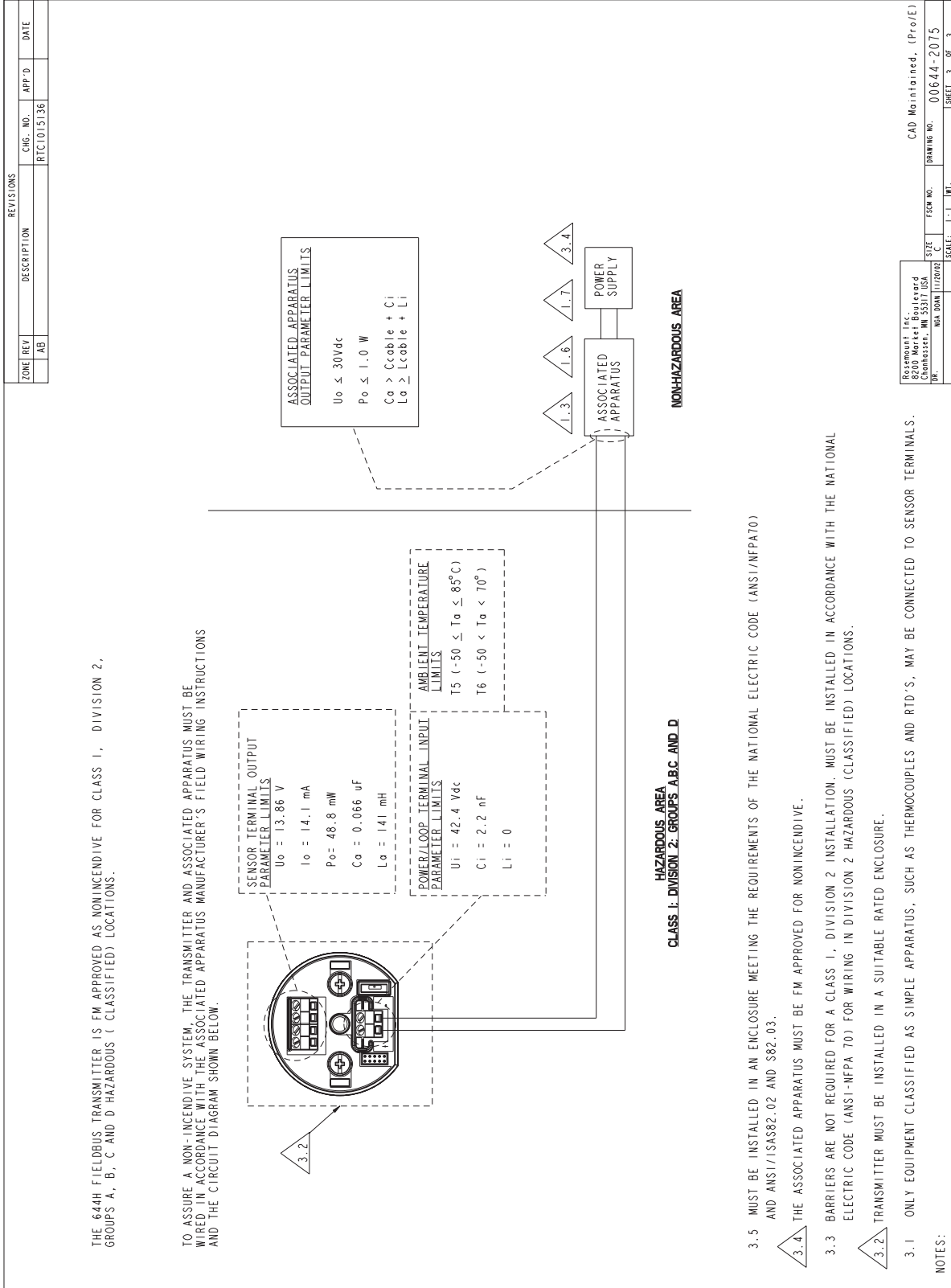

Rosemount Inc. 644-0101-04	SIZE	SCALE	SHEET
Chambers, WI 53117 USA	1:1	1:1	3 OF 3
DR.	NSA D04N 11/22/02	DRAWING NO.	CAD Maintained, (Pro/E)
		00644-2075	

644-0009A01A

Appendix C FOUNDATION Fieldbus Block Information

Resource Block	page C-1
Sensor Transducer Block	page C-5
Analog Input (AI) Function Block	page C-8
LCD Transducer Block	page C-12
PID Block	page C-13

BASIC SETUP

RESOURCE BLOCK

This section contains information on the 644 Resource Block. Descriptions of all Resource Block Parameters, errors, and diagnostics are included. Also the modes, alarm detection, status handling, and troubleshooting are discussed.

Definition

The resource block defines the physical resources of the device. The resource block also handles functionality that is common across multiple blocks. The block has no linkable inputs or outputs.

Parameters and Descriptions

The table below lists all of the configurable parameters of the Resource Block, including the descriptions and index numbers for each.

Parameter	Index Number	Description
ACK_OPTION	38	Selection of whether alarms associated with the function block will be automatically acknowledged.
ADVISE_ACTIVE	82	Enumerated list of advisory conditions within a device.
ADVISE_ALM	83	Alarm indicating advisory alarms. These conditions do not have a direct impact on the process or device integrity.
ADVISE_ENABLE	80	Enabled ADVISE_ALM alarm conditions. Corresponds bit for bit to the ADVISE_ACTIVE. A bit on means that the corresponding alarm condition is enabled and will be detected. A bit off means the corresponding alarm condition is disabled and will not be detected.
ADVISE_MASK	81	Mask of ADVISE_ALM. Corresponds bit of bit to ADVISE_ACTIVE. A bit on means that the condition is masked out from alarming.
ADVISE_PRI	79	Designates the alarming priority of the ADVISE_ALM
ALARM_SUM	37	The current alert status, unacknowledged states, unreported states, and disabled states of the alarms associated with the function block.
ALERT_KEY	04	The identification number of the plant unit.
BLOCK_ALM	36	The block alarm is used for all configuration, hardware, connection failure or system problems in the block. The cause of the alert is entered in the subcode field. The first alert to become active will set the Active status in the Status parameter. As soon as the Unreported status is cleared by the alert reporting task, another block alert may be reported without clearing the Active status, if the subcode has changed.
BLOCK_ERR	06	This parameter reflects the error status associated with the hardware or software components associated with a block. It is a bit string, so that multiple errors may be shown.
CLR_FSTATE	30	Writing a Clear to this parameter will clear the device FAIL_SAFE if the field condition has cleared.
CONFIRM_TIME	33	The time the resource will wait for confirmation of receipt of a report before trying again. Retry will not happen when CONFIRM_TIME=0.
CYCLE_SEL	20	Used to select the block execution method for this resource. The 644 supports the following: Scheduled: Blocks are only executed based on the function block schedule. Block Execution: A block may be executed by linking to another blocks completion.
CYCLE_TYPE	19	Identifies the block execution methods available for this resource.
DD_RESOURCE	09	String identifying the tag of the resource which contains the Device Description for this resource.
DD_REV	13	Revision of the DD associated with the resource - used by an interface device to locate the DD file for the resource.
DEFINE_WRITE_LOCK	60	Allows the operator to select how WRITE_LOCK behaves. The initial value is "lock everything". If the value is set to "lock only physical device" then the resource and transducer blocks of the device will be locked but changes to function blocks will be allowed.
DETAILED_STATUS	55	Indicates the state of the transmitter. See Resource Block detailed status codes.
DEV_REV	12	Manufacturer revision number associated with the resource - used by an interface device to locate the DD file for the resource.
DEV_STRING	43	This is used to load new licensing into the device. The value can be written but will always read back with a value of 0.
DEV_TYPE	11	Manufacturer's model number associated with the resource - used by interface devices to locate the DD file for the resource.
DIAG_OPTIONS	46	Indicates which diagnostics licensing options are enabled.
DISTRIBUTOR	42	Reserved for use as distributor ID. No Foundation enumerations defined at this time.
DOWNLOAD_MODE	67	Gives access to the boot block code for over-the-wire downloads. 0 = Uninitialized 1 = Run mode 2 = Download mode

Parameter	Index Number	Description
FAULT_STATE	28	Condition set by loss of communication to an output block, fault promoted to an output block or physical contact. When FAIL_SAFE condition is set, then output function blocks will perform their FAIL_SAFE actions.
FAILED_ACTIVE	72	Enumerated list of failure conditions within a device.
FAILED_ALM	73	Alarm indicating a failure within a device which makes the device non-operational.
FAILED_ENABLE	70	Enabled FAILED_ALM alarm conditions. Corresponds bit for bit to the FAILED_ACTIVE. A bit on means that the corresponding alarm condition is enabled and will be detected. A bit off means the corresponding alarm condition is disabled and will not be detected.
FAILED_MASK	71	Mask of FAILED_ALM. Corresponds bit of bit to FAILED_ACTIVE. A bit on means that the condition is masked out from alarming.
FAILED_PRI	69	Designates the alarming priority of the FAILED_ALM.
FB_OPTIONS	45	Indicates which function block licensing options are enabled.
FEATURES	17	Used to show supported resource block options. See Error! Reference source not found. The supported features are: SOFT_WRITE_LOCK_SUPPORT, HARD_WRITE_LOCK_SUPPORT, REPORTS, and UNICODE
FEATURE_SEL	18	Used to select resource block options.
FINAL_ASSY_NUM	54	The same final assembly number placed on the neck label.
FREE_SPACE	24	Percent of memory available for further configuration. Zero in a preconfigured device.
FREE_TIME	25	Percent of the block processing time that is free to process additional blocks.
GRANT_DENY	14	Options for controlling access of host computers and local control panels to operating, tuning, and alarm parameters of the block. Not used by device.
HARD_TYPES	15	The types of hardware available as channel numbers.
HARDWARE_REV	52	Hardware revision of the hardware that has the resource block in it.
ITK_VER	41	Major revision number of the inter operability test case used in certifying this device as interoperable. The format and range are controlled by the Fieldbus Foundation.
LIM_NOTIFY	32	Maximum number of unconfirmed alert notify messages allowed.
MAINT_ACTIVE	77	Enumerated list of maintenance conditions within a device.
MAINT_ALM	78	Alarm indicating the device needs maintenance soon. If the condition is ignored, the device will eventually fail.
MAINT_ENABLE	75	Enabled MAINT_ALM alarm conditions. Corresponds bit for bit to the MAINT_ACTIVE. A bit on means that the corresponding alarm condition is enabled and will be detected. A bit off means the corresponding alarm condition is disabled and will not be detected.
MAINT_MASK	76	Mask of MAINT_ALM. Corresponds bit of bit to MAINT_ACTIVE. A bit on means that the condition is masked out from alarming.
MAINT_PRI	74	Designates the alarming priority of the MAINT_ALM
MANUFAC_ID	10	Manufacturer identification number – used by an interface device to locate the DD file for the resource.
MAX_NOTIFY	31	Maximum number of unconfirmed notify messages possible.
MEMORY_SIZE	22	Available configuration memory in the empty resource. To be checked before attempting a download.
MESSAGE_DATE	57	Date associated with the MESSAGE_TEXT parameter.
MESSAGE_TEXT	58	Used to indicate changes made by the user to the device's installation, configuration, or calibration.
MIN_CYCLE_T	21	Time duration of the shortest cycle interval of which the resource is capable.
MISC_OPTIONS	47	Indicates which miscellaneous licensing options are enabled.
MODE_BLK	05	The actual, target, permitted, and normal modes of the block: Target: The mode to “go to” Actual: The mode the “block is currently in” Permitted: Allowed modes that target may take on Normal: Most common mode for actual
NV_CYCLE_T	23	Minimum time interval specified by the manufacturer for writing copies of NV parameters to non-volatile memory. Zero means it will never be automatically copied. At the end of NV_CYCLE_T, only those parameters which have changed need to be updated in NVRAM.
OUTPUT_BOARD_SN	53	Output board serial number.

Parameter	Index Number	Description
RB_SFTWR_REV_ALL	51	The string will contains the following fields: Major rev: 1-3 characters, decimal number 0-255 Minor rev: 1-3 characters, decimal number 0-255 Build rev: 1-5 characters, decimal number 0-255 Time of build: 8 characters, xx:xx:xx, military time Day of week of build: 3 characters, Sun, Mon,... Month of build: 3 characters, Jan, Feb. Day of month of build: 1-2 characters, decimal number 1-31 Year of build: 4 characters, decimal Builder: 7 characters, login name of builder
RB_SFTWR_REV_BUILD	50	Build of software that the resource block was created with.
RB_SFTWR_REV_MAJOR	48	Major revision of software that the resource block was created with.
RB_SFTWR_REV_MINOR	49	Minor revision of software that the resource block was created with.
RECOMMENDED_ACTION	68	Enumerated list of recommended actions displayed with a device alert.
RESTART	16	Allows a manual restart to be initiated. Several degrees of restart are possible. They are the following: 1 Run – nominal state when not restarting 2 Restart resource – not used 3 Restart with defaults – set parameters to default values. See START_WITH_DEFAULTS below for which parameters are set. 4 Restart processor – does a warm start of CPU.
RS_STATE	07	State of the function block application state machine.
SAVE_CONFIG_BLOCKS	62	Number of EEPROM blocks that have been modified since last burn. This value will count down to zero when the configuration is saved.
SAVE_CONFIG_NOW	61	Allows the user to optionally save all non-volatile information immediately.
SECURITY_IO	65	Status of security switch.
SELF_TEST	59	Instructs resource block to perform self-test. Tests are device specific.
SET_FSTATE	29	Allows the FAIL_SAFE condition to be manually initiated by selecting Set.
SHED_RCAS	26	Time duration at which to give up on computer writes to function block RCas locations. Shed from RCas shall never happen when SHED_ROUT = 0
SHED_ROUT	27	Time duration at which to give up on computer writes to function block ROut locations. Shed from ROut shall never happen when SHED_ROUT = 0
SIMULATE_IO	64	Status of simulate switch.
SIMULATE_STATE	66	The state of the simulate switch: 0 = Uninitialized 1 = Switch off, simulation not allowed 2 = Switch on, simulation not allowed (need to cycle jumper/switch) 3 = Switch on, simulation allowed
ST_REV	01	The revision level of the static data associated with the function block.
START_WITH_DEFAULTS	63	0 = Uninitialized 1 = do not power-up with NV defaults 2 = power-up with default node address 3 = power-up with default pd_tag and node address 4 = power-up with default data for the entire communications stack (no application data)
STRATEGY	03	The strategy field can be used to identify grouping of blocks.
SUMMARY_STATUS	56	An enumerated value of repair analysis.
TAG_DESC	02	The user description of the intended application of the block.
TEST_RW	08	Read/write test parameter - used only for conformance testing.
UPDATE_EVT	35	This alert is generated by any change to the static data.
WRITE_ALM	40	This alert is generated if the write lock parameter is cleared.
WRITE_LOCK	34	If set, no writes from anywhere are allowed, except to clear WRITE_LOCK. Block inputs will continue to be updated.
WRITE_PRI	39	Priority of the alarm generated by clearing the write lock.
XD_OPTIONS	44	Indicates which transducer block licensing options are enabled.

SENSOR TRANSDUCER BLOCK

The transducer block contains the actual measurement data, including a pressure and temperature reading. The transducer block includes information about sensor type, engineering units, linearization, reranging, temperature compensation, and diagnostics.

Parameters and Descriptions

Parameter	Index Number	Description	Notes on how changing this parameter affects transmitter operation.
ALERT_KEY	04	The identification number of the plant unit.	No effect on operation of transmitter but may affect the way alerts are sorted on the host end.
BLOCK_ALM	08	The block alarm is used for all configuration, hardware, connection failure or system problems in the block. The cause of the alert is entered in the subcode field. The first alert to become active will set the Active status in the Status parameter. As soon as the Unreported status is cleared by the alert reporting task, another block alert may be reported without clearing the Active status, if the subcode has changed.	No effect.
BLOCK_ERR	06	This parameter reflects the error status associated with the hardware or software components associated with a block. It is a bit string, so that multiple errors may be shown.	No effect.
CAL_MIN_SPAN	18	The minimum calibration span value allowed. This minimum span information is necessary to ensure when calibration is done, the two calibrated points are not too close together.	No effect.
CAL_POINT_HI	16	The highest calibrated value.	Assigns a value to the calibration high point.
CAL_POINT_LO	17	The lowest calibrated value.	Assigns a value to the calibration low point.
CAL_UNIT	19	The device description engineering units code index for the calibration values.	Device must be calibrated using the appropriate engineering units.
COLLECTION_DIRECTORY	12	A directory that specifies the number, starting indices, and DD Item ID's of the data collections in each transducer.	No effect.
ASIC_REJECTION	42	Indicates the type of material that the drain vents on the flange are made of. See Drain Vent Material Codes.	
FACTORY_CAL_RECALL	32	Recalls the sensor calibration set at the factory.	
USER_2W_OFFSET	36	Indicates the type of material that the flange is made of. See Flange Material Codes.	
INTER_DETECT_THRESH	35	Indicates the type of flange that is attached to the device. See Flange Type Codes.	
MODE_BLK	05	The actual, target, permitted, and normal modes of the block. Target: The mode to "go to" Actual: The mode the "block is currently in" Permitted: Allowed modes that target may take on Normal: Most common mode for target	Assigns the device mode.
CALIBRATOR_MODE	33	Indicates the type of sensor module.	
PRIMARY_VALUE	14	The measured value and status available to the function block.	No effect.

Parameter	Index Number	Description	Notes on how changing this parameter effects transmitter operation.
PRIMARY_VALUE_RANGE	15	The high and low range limit values, the engineering unit code, and the number of digits to the right of the decimal point to be used to display the final value. Valid engineering units are the following: 1130 = Pa 1133 = kPa 1137 = bar 1138 = mbar 1139 = torr 1140 = atm 1141 = psi 1144 = g/cm ² 1145 = kg/cm ² 1148 = inH ₂ O @ 68 °F 1151 = mmH ₂ O @ 68 °F 1154 = ftH ₂ O @ 68 °F 1156 = inHg @ 0 °C 1158 = mmHg @ 0 °C	No effect.
PRIMARY_VALUE_TYPE	13	Type of measurement represented by the primary value. 107 = Differential pressure 108 = Gage pressure 109 = Absolute pressure	No effect.
SENSR_DETAILED_STATUS	37	Indicates the number of remote seals that are attached to the device. See Remote Seal Number Codes.	
CAL_VAN_DUSEN_COEFF	38	Indicates the type of remote seals that are attached to the device. See Remote Seal Type Codes.	
SECONDARY_VALUE_RANG	30	The secondary value, related to the sensor.	No effect.
SECONDARY_VALUE_UNIT	29	Engineering units to be used with SECONDARY_VALUE. 1001 °C 1002 °F	No effect.
SENSOR_CAL_DATE	25	The last date on which the calibration was performed. This is intended to reflect the calibration of that part of the sensor that is usually wetted by the process.	No effect.
SENSOR_CAL_LOC	24	The last location of the sensor calibration. This describes the physical location at which the calibration was performed.	No effect.
SENSOR_CAL_METHOD	23	The method of last sensor calibration.	No effect.
OPEN_SNSR_HOLDOFF	34	The type of last sensor calibration.	No effect.
SENSOR_CAL_WHO	26	The name of the person responsible for the last sensor calibration.	No effect.
SECONDARY_VALUE	28	Defines the type of fill fluid used in the sensor.	No effect.
SENSOR_CONNECTION	27	Defines the construction material of the isolating diaphragms.	No effect.
SENSOR_RANGE	21	The high and low range limit values, the engineering units code, and the number of digits to the right of the decimal point for the sensor.	No effect.
SENSOR_SN	22	Serial number of the sensor.	No effect.
SENSOR_TYPE	20	Type of sensor connected with the transducer block.	No effect.
ST_REV	01	The revision level of the static data associated with the function block.	No effect.

Parameter	Index Number	Description	Notes on how changing this parameter effects transmitter operation.
STRATEGY	03	The strategy field can be used to identify grouping of blocks.	No effect.
TAG_DESC	02	The user description of the intended application of the block.	No effect.
SESNOR_1_DAMPING	31	Indicates the state of the transmitter. The parameter contains specific codes relating to the transducer block and the pressure sensor specifically.	No effect.
TRANSDUCER_DIRECTORY	09	Directory that specifies the number and starting indices of the transducers in the transducer block.	No effect.
TRANSDUCER_TYPE	10	Identifies the transducer that follows.	No effect.
UPDATE_EVT	07	This alert is generated by any change to the static data.	No effect.
XD_ERROR	11	Provides additional error codes related to transducer blocks.	No effect.

**ANALOG INPUT (AI)
FUNCTION BLOCK**

The Analog Input (AI) function block processes field device measurements and makes them available to other function blocks. The output value from the AI block is in engineering units and contains a status indicating the quality of the measurement. The measuring device may have several measurements or derived values available in different channels. Use the channel number to define the variable that the AI block processes.

The AI block supports alarming, signal scaling, signal filtering, signal status calculation, mode control, and simulation. In Automatic mode, the block's output parameter (OUT) reflects the process variable (PV) value and status. In Manual mode, OUT may be set manually. The Manual mode is reflected on the output status. A discrete output (OUT_D) is provided to indicate whether a selected alarm condition is active. Alarm detection is based on the OUT value and user specified alarm limits. Figure C-1 illustrates the internal components of the AI function block, and Table C-1 lists the AI block parameters and their units of measure, descriptions, and index numbers.

Figure C-1. AI Function Block

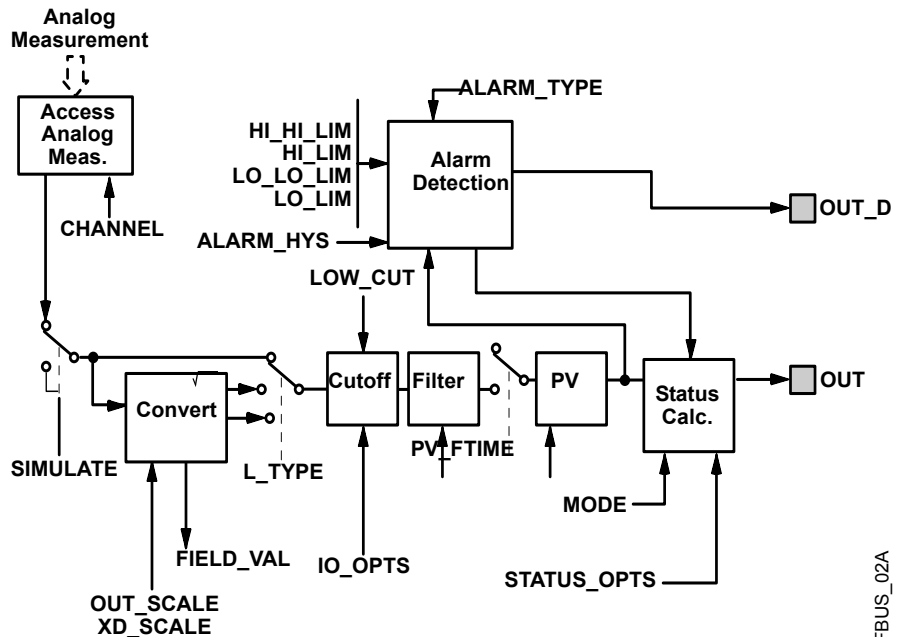

NOTES:
OUT = block output value and status.
OUT_D = discrete output that signals a selected alarm condition.

FIELDBUS-FBUS_02A

AI Parameter Table

Table C-1. Definitions of Analog Input Function Block System Parameters.

Parameter	Index No.	Available Values	Units	Default	Read/Write	Description
ACK_OPTION	23	0 = Auto Ack Disabled 1 = Auto Ack Enabled	None	0 all Disabled	Read and Write	Used to set auto acknowledgment of alarms.
ALARM_HYS	24	0 – 50	Percent	0.5	Read and Write	The amount the alarm value must return within the alarm limit before the associated active alarm condition clears.
ALM_SEL	38	HI_HI, HI, LO, LO_LO	None	Non selected	Read and Write	Used to select the process alarm conditions that will cause the OUT_D parameter to be set.
ALARM_SUM	22	Enable/Disable	None	Enable	Read and Write	The summary alarm is used for all process alarms in the block. The cause of the alert is entered in the subcode field. The first alert to become active will set the Active status in the Status parameter. As soon as the Unreported status is cleared by the alert reporting task, another block alert may be reported without clearing the Active status, if the subcode has changed.
ALERT_KEY	04	1 – 255	None	0	Read and Write	The identification number of the plant unit. This information may be used in the host for sorting alarms, etc.
BLOCK_ALM	21	Not applicable	None	Not applicable	Read only	The block alarm is used for all configuration, hardware, connection failure or system problems in the block. The cause of the alert is entered in the subcode field. The first alert to become active will set the Active status in the Status parameter. As soon as the Unreported status is cleared by the alert reporting task, another block alert may be reported without clearing the Active status, if the subcode has changed.
BLOCK_ERR	06	Not applicable	None	Not applicable	Read only	This parameter reflects the error status associated with the hardware or software components associated with a block. It is a bit string, so that multiple errors may be shown.
CAP_STDDEV	40	> = 0	Seconds	0	Read and Write	The time over which the VAR_INDEX is evaluated.
CHANNEL	15	1 = Pressure 2 = Housing temperature	None	AI ⁽¹⁾ : Channel = 1 AI2: Channel = 2	Read and Write	The CHANNEL value is used to select the measurement value. Refer to the appropriate device manual for information about the specific channels available in each device. You must configure the CHANNEL parameter before you can configure the XD_SCALE parameter.
FIELD_VAL	19	0 – 100	Percent	Not applicable	Read only	The value and status from the transducer block or from the simulated input when simulation is enabled.
GRANT_DENY	12	Program Tune Alarm Local	None	Not applicable	Read and Write	Normally the operator has permission to write to parameter values, but Program or Local remove that permission and give it to the host controller or a local control panel.
HI_ALM	34	Not applicable	None	Not applicable	Read only	The HI alarm data, which includes a value of the alarm, a timestamp of occurrence and the state of the alarm.
HI_HI_ALM	33	Not applicable	None	Not applicable	Read only	The HI HI alarm data, which includes a value of the alarm, a timestamp of occurrence and the state of the alarm.
HI_HI_LIM	26	Out_Scale ⁽²⁾	Out_Scale ⁽²⁾	Not applicable	Read and Write	The setting for the alarm limit used to detect the HI HI alarm condition.
HI_HI_PRI	25	0 – 15	None	1	Read and Write	The priority of the HI HI alarm.
HI_LIM	28	Out_Scale ⁽²⁾	Out_Scale ⁽²⁾	Not applicable	Read and Write	The setting for the alarm limit used to detect the HI alarm condition.
HI_PRI	27	0 – 15	None	1	Read and Write	The priority of the HI alarm.
IO_OPTS	13	Low Cutoff Enable/Disable	None	Disable	Read and Write	Allows the selection of input/output options used to alter the PV. Low cutoff enabled is the only selectable option.

Parameter	Index No.	Available Values	Units	Default	Read/Write	Description
L_TYPE	16	Direct Indirect Indirect Square Root	None	Direct	Read and Write	Linearization type. Determines whether the field value is used directly (Direct), is converted linearly (Indirect), or is converted with the square root (Indirect Square Root).
LO_ALM	35	Not applicable	None	Not applicable	Read only	The LO alarm data, which includes a value of the alarm, a timestamp of occurrence and the state of the alarm.
LO_LIM	30	Out_Scale ⁽²⁾	Out_Scale ⁽²⁾	Not applicable	Read and Write	The setting for the alarm limit used to detect the LO alarm condition.
LO_LO_ALM	36	Not applicable	None	Not applicable	Read only	The LO LO alarm data, which includes a value of the alarm, a timestamp of occurrence and the state of the alarm.
LO_LO_LIM	32	Out_Scale ⁽²⁾	Out_Scale ⁽²⁾	Not applicable	Read and Write	The setting for the alarm limit used to detect the LO LO alarm condition.
LO_LO_PRI	31	0 – 15	None	1	Read and Write	The priority of the LO LO alarm.
LO_PRI	29	0 – 15	None	1	Read and Write	The priority of the LO alarm.
LOW_CUT	17	> = 0	Out_Scale ⁽²⁾	0	Read and Write	If percentage value of transducer input fails below this, PV = 0.
MODE_BLK	05	Auto Manual Out of Service	None	Not applicable	Read and Write	The actual, target, permitted, and normal modes of the block. Target: The mode to “go to” Actual: The mode the “block is currently in” Permitted: Allowed modes that target may take on Normal: Most common mode for target
OUT	08	Out_Scale ⁽²⁾ ± 10%	Out_Scale ⁽²⁾	Not applicable	Read and Write	The block output value and status.
OUT_D	37	Discrete_State 1 – 16	None	Disabled	Read and Write	Discrete output to indicate a selected alarm condition.
OUT_SCALE	11	Any output range	All available	none	Read and Write	The high and low scale values, engineering units code, and number of digits to the right of the decimal point associated with OUT.
PV	07	Not applicable	Out_Scale ⁽²⁾	Not applicable	Read only	The process variable used in block execution.
PV_FTIME	18	> = 0	Seconds	0	Read and Write	The time constant of the first-order PV filter. It is the time required for a 63% change in the IN value.
SIMULATE	09	Not applicable	None	Disable	Read and Write	A group of data that contains the current transducer value and status, the simulated transducer value and status, and the enable/disable bit.
ST_REV	01	Not applicable	None	0	Read only	The revision level of the static data associated with the function block. The revision value will be incremented each time a static parameter value in the block is changed.
STATUS_OPTS	14	Propagate fault forward Uncertain if Limited Bad if Limited Uncertain if Man Mode		0	Read and Write	
STDDEV	39	0 – 100	Percent	0	Read and Write	The average absolute error between the PV and its previous mean value over that evaluation time defined by VAR_SCAN.
STRATEGY	03	0 – 65535	None	0	Read and Write	The strategy field can be used to identify grouping of blocks. This data is not checked or processed by the block.

Parameter	Index No.	Available Values	Units	Default	Read/Write	Description
TAG_DESC	02	32 text characters	None	none	Read and Write	The user description of the intended application of the block.
UPDATE_EVT	20	Not applicable	None	Not applicable	Read only	This alert is generated by any change to the static data.
XD_SCALE	10	Any sensor range	inH ₂ O (68 °F) inHg (0 °C) ftH ₂ O (68 °F) mmH ₂ O (68 °F) mmHg (0 °C) psi bar mbar g/cm ² kg/cm ² Pa kPa torr atm deg C deg F	AI1 ⁽¹⁾ : Customer specification inH ₂ O (68 °F) for DP/GP rng 1, 2, 3) or psi for DP/GP rng 4, 5 AP/644 all rng AI2 deg C		In all Rosemount devices the units of the transducer block is forced to match the unit code.

(1) The host system may write over default values pre-configured by Rosemount Inc.
 (2) Assume that when L_Type = Direct, the user configures Out_Scale which is equal to XD_Scale

LCD TRANSDUCER BLOCK

Parameter	Index	Description
ALERT_KEY	4	The identification number of the plant unit.
BLK_TAG_1	15	The tag of the block containing DP1.
BLK_TAG_2	21	The tag of the block containing DP2.
BLK_TAG_3	27	The tag of the block containing DP3.
BLK_TAG_4	33	The tag of the block containing DP4.
BLK_TYPE_1	14	The enumerated block type for DP1's block.
BLK_TYPE_2	20	The enumerated block type for DP2's block.
BLK_TYPE_3	26	The enumerated block type for DP3's block.
BLK_TYPE_4	32	The enumerated block type for DP4's block.
BLOCK_ALM	8	The BLOCK_ALM is used for all configuration, hardware, connection failure or system problems in the block. The cause of the alert is entered in the subcode field. The first alert to become active will set the Active status in the Status attribute. As soon as the Unreported status is cleared by the alert reporting task, another block alert may be reported without clearing the Active status, if the subcode has changed.
BLOCK_ERR	6	This parameter reflects the error status associated with the hardware or software components associated with a block. it is a bit string, so that multiple errors may be shown.
COLLECTION_DIRECTORY	12	A directory that specifies the number, starting indices, and DD Item ID's of the data collections in each transducer block.
CUSTOM_TAG_1	17	The block description that is displayed for DP1.
CUSTOM_TAG_2	23	The block description that is displayed for DP2.
CUSTOM_TAG_3	29	The block description that is displayed for DP3.
CUSTOM_TAG_4	35	The block description that is displayed for DP4.
CUSTOM_UNITS_1	19	This is the user entered units that are displayed when UNITS_TYPE_1=Custom.
CUSTOM_UNITS_2	25	This is the user entered units that are displayed when UNITS_TYPE_2=Custom.
CUSTOM_UNITS_3	31	This is the user entered units that are displayed when UNITS_TYPE_3=Custom.
CUSTOM_UNITS_4	37	This is the user entered units that are displayed when UNITS_TYPE_4=Custom.
DISPLAY_PARAM_SEL	13	This will determine which Display Parameters are active. Bit 0 = DP1 Bit 1 = DP2 Bit 2 = DP3 Bit 3 = DP4 Bit 4 = Bar Graph enable
MODE_BLK	5	The actual, target, permitted, and normal modes of the block.
PARAM_INDEX_1	16	The relative index of DP1 within its block.
PARAM_INDEX_2	22	The relative index of DP2 within its block.
PARAM_INDEX_3	28	The relative index of DP3 within its block.
PARAM_INDEX_4	34	The relative index of DP4 within its block.
ST_REV	1	The revision level of the static data associated with the function block.
STRATEGY	3	The strategy field can be used to identify grouping of blocks.
TAG_DESC	2	The user description of the intended application of the block.
TRANSDUCER_DIRECTORY	9	A directory that specifies the number and starting indices of the transducers in the transducer block.
TRANSDUCER_TYPE	10	Identifies the transducer that follows.
UNITS_TYPE_1	18	This parameter determines where the units for the display parameter come from.
UNITS_TYPE_2	24	This parameter determines where the units for the display parameter come from.
UNITS_TYPE_3	30	This parameter determines where the units for the display parameter come from.
UNITS_TYPE_4	36	This parameter determines where the units for the display parameter come from.
UPDATE_EVT	7	This alert is generated by any change to the static data.
XD_ERROR	11	Provides additional error codes related to transducer blocks.

PID BLOCK

Parameter	Index
ACK_OPTIONS	46
ALARM_HYS	47
ALARM_SUM	45
ALERT_KEY	4
BAL_TIME	25
BETA	73
BIAS	66
BKCAL_HYS	30
BKCAL_IN	27
BKCAL_OUT	31
BLOCK_ALARM	44
BLOCK_ERR	6
BYPASS	17
CAP_STDDEV	76
CAS_IN	18
CONTROL_OPS	13
DV_HI_ALM	64
DV_HI_LIM	57
DV_HI_PRI	56
DV_LO_ALM	65
DV_LO_LIM	59
DV_LO_PRI	58
ERROR	67
FF_GAIN	42
FF_SCALE	41
FF_VAL	40
GAIN	23
GAMMA	72
GRANT_DENY	12
HI_ALM	61
HI_HI_ALM	60

Parameter	Index
HI_HI_LIM	49
HI_HI_PRI	48
HI_LIM	51
HI_PRI	50
IDEADBAND	74
IN	15
LO_ALM	62
LO_LIM	53
LO_LO_ALM	63
LO_LO_LIM	55
LO_LO_PRI	54
LO_PRI	52
MATHFORM	70
MODE_BLK	5
OUT	9
OUT_HI_LIM	28
OUT_LO_LIM	29
OUT_SCALE	11
PV	7
PV_FTIME	16
PV_SCALE	10
RATE	26
RCAS_IN	32
RCAS_OUT	35
RESET	24
ROUT_IN	33
ROUT_OUT	36
SHED_OPT	34
SP	8
SP_FTIME	69
SP_HI_LIM	21

Parameter	Index
SP_LO_LIM	22
SP_RATE_DN	19
SP_RATE_UP	20
SP_WORK	68
ST_REV	1
STATUS_OPTS	14
STDDEV	75
STRATEGY	3
STRUCTURECONFIG	71
T_AOPERIODS	92
T_AUTO_EXTRA_DT	90
T_AUTO_HYSTERESIS	91
T_GAIN_MAGNIFIER	89
T_HYSTER	87
T_IPGAIN	80
T_PDTIME	85
T_PSGAIN	83
T_PTIMEC	84
T_RELAYSS	88
T_REQUEST	77
T_STATE	78
T_STATUS	79
T_TARGETTOP	86
T_UGAIN	81
T_UPERIOD	82
TAG_DESC	2
TRK_IN_D	38
TRK_SCALE	37
TRK_VAL	39
UPDATE_EVT	43

Index

Numerics

275 HART Communicator
 Apply AMS Changes 3-6

A

Address 4-2
 Temporary Node 4-2
 Advanced Diagnostics Transducer
 Block (ADB) 4-4
 Advanced Features 4-13
 ADVISE_ACTIVE 4-8
 ADVISE_ALM 4-8
 ADVISE_ENABLED 4-8
 ADVISE_MASK 4-8
 ADVISE_PRI 4-8
 Advisory Alarms 4-7
 ADVISE_ACTIVE 4-8
 ADVISE_ALM 4-8
 ADVISE_MASK 4-8
 ADVISE_PRI 4-8
 AI Block. See Analog Input (AI) Function
 Block
 Alarm Priority 4-12
 ALARM_TYPE 4-13
 Alarms
 ADVISE_ACTIVE 4-8
 ADVISE_ALM 4-8
 ADVISE_MASKParameter
 ADVISE_MASK 4-8
 ADVISE_PRI 4-8
 Advisory 4-7
 ALARM_TYPE 4-13
 FAILED_ACTIVE 4-7
 FAILED_ALARMS 4-6
 FAILED_ALM 4-7
 FAILED_ENABLED 4-6
 FAILED_MASK 4-6
 FAILED_PRI 4-7
 MAINT_ACTIVE 4-7
 MAINT_ALARMS 4-7
 MAINT_ALM 4-7
 MAINT_ENABLED 4-7
 MAINT_MASK 4-7
 MAINT_PRI 4-7
 PlantWeb 4-6, 4-8
 Priority 4-12
 Process 4-12

AMS 3-6
 2-Wire RTD Offset 3-11
 Alarm and Saturation 3-16
 Change Connections 3-8
 Change Type 3-8
 Device Information 3-12
 LCD Meter Options 3-10
 Loop Test 3-13
 Master Reset 3-14
 Multidrop Communication 3-19
 Open Sensor Holdoff 3-18
 Output Units 3-9
 Process Variable Damping 3-11,
 3-14, 3-15
 Process Variables 3-7
 Review 3-7
 Scaled Output Trim 3-23
 Sensor 1 Serial Number 3-8
 Sensor Input Trim 3-20
 Terminal Temperature 3-9
 Transmitter-Sensor Matching 3-22
 Variable Mapping 3-7
 Analog Input (AI) block C-8
 Analog Input (AI) Function Block 4-4,
 4-9, C-8
 ALARM_TYPE 4-13
 Block Information C-8
 BLOCK_ERR 4-21
 Configuration 4-9
 OUT_D 4-13
 Parameters C-9
 PV_FTIME 4-12
 Status 4-12

B

BAD if Limited 4-12
 BLK_TAG_# 4-14
 BLK_TYPE_# 4-14
 BLOCK_ERR
 AI Block 4-21
 Resource Block 4-22

C

Calibration 3-19
 Trim 3-19

Capabilities 4-4
 Block Execution Times 4-4
 Host Timer 4-4
 VCRs 4-4
 Changing Modes 4-2
 Channel 4-9, 4-10
 Check Output 3-7
 Commissioning 3-2
 Failure Mode 3-2
 Set Loop to Manual 3-2
 Switch Positions 3-3
 Configuration 3-3, 3-7
 Analog Input (AI) Function Block 4-9
 XD_SCALE, OUT_SCALE 4-9
 Channel 4-9
 Check Output 3-7
 Configuration 3-7
 Custom Meter 4-13
 Diagnostics 3-13
 Direct 4-10
 Examples 4-10
 Fast Key Sequence 3-5
 HART Menu Tree 3-4
 Information Variables 3-12
 L_TYPE 4-9
 Direct 4-9
 Indirect 4-9, 4-10
 LCD Transducer Block 4-13
 Resource Block 4-4
 Review Configuration Data 3-7
 Service 3-13
 Considerations 1-3
 Commissioning 1-3
 Electrical 1-3
 Environmental 1-3
 Temperature 1-3
 General 1-3
 Mechanical 1-3
 Location 1-3
 Special Mounting 1-3
 Custom meter configuration 4-13
 CUSTOM_TAG_# 4-14
 CUSTOM_UNITS_# 4-14

D

Damping 4-9

Diagnostic Messages	3-24	H	Hardware	3-24	Information Variables	3-12
Hardware	3-24	Hardware	Diagnostic Messages	3-24	Installation	2-4
LCD Display	3-29	Diagnostic Messages	Maintenance	3-24	European	2-4
Diagnostics and Service	3-13	Maintenance	HART Communicator		Head Mount	2-4
Diagram		HART Communicator	Check Output	3-7	Flowchart	2-2
Sensor Wiring	2-11	Check Output	Commands		LCD Display	2-8
Direct	4-9, 4-10	Commands	2-Wire RTD Offset	3-11	Multichannel	2-9
DISPLAY_PARAM_SEL	4-13	2-Wire RTD Offset	50/60 Hz Filter	3-9	North American	2-5
E		Active Calibrator	Active Calibrator	3-14	Head Mount	2-5
Examples, Configuration	4-10	Alarm	Alarm	3-15	Rail Mount	2-6, 2-7
Typical Pressure	4-12	Date	Date	3-12	Instantiation, Block	4-3
Execution Times	4-4	Descriptor	Descriptor	3-12	Intermittent Sensor Detect	3-17
F		HART Output	HART Output	3-15	L	
FAILED_ACTIVE alarms	4-7	Intermittent Threshold	Intermittent Threshold	3-16	L_TYPE	4-9
FAILED_ALARMS	4-6	LCD Meter Options	LCD Meter Options	3-9	4-9, 4-10
FAILED_ACTIVE	4-7	Loop Test	Loop Test	3-13	LCD Display	
FAILED_ALM	4-7	Master Reset	Master Reset	3-14	Diagnostic Messages	3-29
FAILED_ENABLED	4-6	Message	Message	3-12	Installation	2-8
FAILED_MASK	4-6	Open Sensor Holdoff	Open Sensor Holdoff	3-18	LCD meter	4-13
FAILED_PRI	4-7	Output Trim	Output Trim	3-23	LCD Transducer Block	4-4, 4-13, C-12
FAILED_ALM	4-7	Process Variables	Process Variables	3-7	Messaging	4-13
FAILED_ENABLED alarms	4-6	PV Damping	PV Damping	3-10	Parameters	C-12
FAILED_MASK alarms	4-6	PV Range Values	PV Range Values	3-16	LCD Transducer block	4-23
FAILED_PRI alarms	4-7	Rerange	Rerange	3-16	Block Error	4-23
Failure Mode	3-2	Review	Review	3-7	Self Test	4-23
Fast Key Sequence	3-5	Saturation	Saturation	3-15	LIM_NOTIFY	4-6
FEATURES		Scaled Output Trim	Scaled Output Trim	3-23	Limited	
FEATURES_SEL	4-6	Select Sensor Type	Select Sensor Type	3-8	Bad	4-12
Features	4-5	Sensor Input Trim	Sensor Input Trim	3-20	Uncertain	4-12
Advanced	4-13	Sensor Matching	Sensor Matching	3-21	Link Active Scheduler	4-3
FEATURES, FEATURES_SEL	4-5	Sensor Review	Sensor Review	3-14	LO_LIM	4-12
Features	4-5	Sensor Serial Number	Sensor Serial Number	3-8	LO_LO_LIM	4-12
Reports	4-5	Set Output Units	Set Output Units	3-8	LO_LO_PRI	4-12
Soft W Lock, Hard W Lock	4-5	Tag	Tag	3-12	LO_PRI	4-12
Unicode	4-5	Terminal Temperature	Terminal Temperature	3-9	Lower Trim Method	4-17
Filtering	4-12	Test Device	Test Device	3-13	M	
AI block	4-12	Variable Mapping	Variable Mapping	3-7	MAINT_ACTIVE	4-7
Foundation fieldbus function blocks	4-4	Write Protect	Write Protect	3-15	MAINT_ALARMS	4-7
FREE_SPACE	4-3	Configuration	Configuration	3-7	MAINT_ACTIVE	4-7
.		see Configuration	see Configuration	3-3	MAINT_ALM	4-7
G		Diagnostics	Diagnostics	3-13	MAINT_ENABLED	4-7
General Block Information		Fast Key Sequence	Fast Key Sequence	3-5	MAINT_MASK	4-7
Block Instantiation	4-2	Hart Menu Tree	Hart Menu Tree	3-4	MAINT_PRI	4-7
Capabilities	4-2	Information Variables	Information Variables	3-12	MAINT_ALM	4-7
Link Active Scheduler	4-2	Review Configuration Data	Review Configuration Data	3-7	MAINT_ENABLED	4-7
Modes	4-2	Service	Service	3-13	MAINT_MASK	4-7
Ground the Transmitter	3-2	HART Menu Tree	HART Menu Tree	3-4	MAINT_PRI	4-7
Grounded		Hazardous Locations Installations	Hazardous Locations Installations		MAINT_ALM	4-7
Thermocouple	2-15	Installation drawings	Installation drawings	B-8	MAINT_ENABLED	4-7
Ungrounded		HI_HI_LIM	HI_HI_LIM	4-12	MAINT_MASK	4-7
Millivolt	2-14	HI_HI_PRI	HI_HI_PRI	4-12	MAINT_PRI	4-7
RTD/Ohm	2-14	HI_LIM	HI_LIM	4-12	Maintenance	3-24
Thermocouple	2-14	HI_PRI	HI_PRI	4-12	Manual Mode	4-20
I		I			Manual Operation	4-14
Indirect	4-9, 4-10	Indirect	Indirect	4-9, 4-10	MAX_NOTIFY	4-6
					LIM_NOTIFY	4-6
					Methods	4-14

Millivolt			
Ungrounded	2-14		
Wiring	2-11		
MODE_BLK.TARGET	4-2		
MODE_BLOCK.ACTUAL	4-2		
Modes			
Changing Modes	4-2		
Permitted Modes	4-2		
Types of Modes	4-2		
Auto	4-2		
Man	4-2		
Other	4-2		
Out of Service	4-2		
Mounting	2-3		
Model 644H			
DIN Rail	2-3		
Threaded Sensor	2-3		
Multichannel			
Installation	2-9		
Multidrop Communication	3-18		
N			
Network Parameters	4-4		
Node address	4-2		
O			
Ohm			
Ungrounded	2-14		
Wiring	2-11		
Operation and Maintenance			
Sensor Transducer Block	4-17		
OUT_D	4-13		
AI block	4-13		
Overview	1-2		
Manual	1-2		
Transmitter	1-2		
P			
PARAM_INDEX_#	4-14		
Parameter			
ADVISE_ACTIVE	4-8		
ADVISE_ALM	4-8		
ADVISE_ENABLED	4-8		
ADVISE_PRI	4-8		
ALARM_TYPE	4-13		
Analog Input (AI) Function Block	C-9		
BLK_TAG_#	4-14		
BLK_TYPE_#	4-14		
BLOCK_ERR	4-21, 4-22		
CHANNEL	4-9		
CUSTOM_TAG_#	4-14		
CUSTOM_UNITS_#	4-14		
DEFINE_WRITE_LOCK	4-5		
DISPLAY_PARAM_SEL	4-13		
FAILED_ACTIVE	4-7		
FAILED_ALARMS	4-6		
FAILED_ALM	4-7		
FAILED_ENABLED	4-6		
FAILED_MASK	4-6		
FAILED_PRI	4-7		
FEATURES	4-5		
FEATURES_SEL	4-6		
FREE_SPACE	4-3		
HI_HI_LIM	4-12		
HI_HI_PRI	4-12		
HI_LIM	4-12		
HI_PRI	4-12		
L_TYPE	4-9, 4-10		
LCD Transducer Block	C-12		
LIM_NOTIFY	4-6		
LO_LIM	4-12		
LO_LO_LIM	4-12		
LO_LO_PRI	4-12		
LO_PRI	4-12		
MAINT_ACTIVE	4-7		
MAINT_ALARMS	4-7		
MAINT_ALM	4-7		
MAINT_ENABLED	4-7		
MAINT_MASK	4-7		
MAINT_PRI	4-7		
MAX_NOTIFY	4-6		
MODE_BLK.TARGET	4-2		
MODE_BLOCK.ACTUAL	4-2		
Network	4-4		
OUT_D	4-13		
OUT_SCALE	4-9		
PARAM_INDEX_#	4-14		
PV_FTIME	4-9, 4-12		
RECOMMENDED_ACTION	4-8		
REPORTS	4-5		
Resource Block	C-2		
Sensor Transducer Block	C-5		
STATUS_OPTIONS	4-12		
UNICODE	4-5		
UNITS_TYPE_#	4-14		
WRITE_LOCK	4-5		
XD_SCALE	4-9		
Performance specifications	A-3		
Permitted Modes	4-2		
PID Block	4-4		
PID block	4-4		
PlantWeb Alarms	4-6, 4-8		
Advisory	4-7		
FAILED_ALARMS	4-6		
MAINT_ALARMS	4-7		
Power Supply	2-13		
Ground	3-2		
Surges	3-2		
Transients	3-2		
Process Alarms	4-12		
Propagate Fault Forward	4-12		
Proportional/Integral/Derivative (PID)			
function block	4-4		
PV_FTIME	4-9		
AI block	4-12		
R			
Recommended Actions	4-8		
PlantWeb Alarms	4-8		
RECOMMENDED_ACTION	4-8		
Reference data	A-9		
Reports	4-5		
Resource Block	4-4, 4-22, C-1		
Block Errors	4-22		
Block Information	C-1		
Configuration	4-4		
Detailed Status	4-22		
FEATURES, FEATURES_SEL	4-5		
Parameters	C-2		
BLOCK_ERR	4-22		
Summary Status	4-22		
Resource block	C-1		
Return of Materials	1-4		
Review Configuration Data	3-7		
RTD			
Ungrounded	2-14		
Wiring	2-11		
S			
Security	4-5		
Self Test	4-23		
Sensor			
Connection			
Diagram	2-11		
Millivolt	2-11		
Ohm	2-11		
RTD	2-11		
Thermocouple	2-11		
Wiring	2-11		
Sensor Calibration	4-17		

Rosemount 644

Sensor Transducer Block . . . 4-4, 4-9, 4-17,	C-5	V	Virtual Communication Relationship (VCRs)	4-4
Block Information	C-5		Network Parameters	4-4
Configuration	4-9			
Operation and Maintenance	4-17	W	Wiring	2-9
Parameters	C-5		Sensor Connection	2-11
Set			Diagram	2-11
Loop to Manual	3-2		Millivolt	2-11
Simulate	4-20		Ohm	2-11
Simulation	4-20		RTD	2-11
Manual Mode	4-20		Thermocouple	2-11
Soft W Lock, Hard W Lock	4-5			
Specifications		X	XD_SCALE	4-9
Performance	A-3		XD_SCALE, OUT_SCALE	4-9
Status	4-20		L_TYPE	
AI block	4-12		Direct	4-10
STATUS_OPTIONS	4-12	Z	Zero Trim	4-9
Supported Units	4-10			
Surges/Transients	3-2			
Switches				
Simulate	4-20			
T				
Thermocouple				
Grounded	2-15			
Ungrounded	2-14			
Wiring	2-11			
Transmitter-Sensor Matching	3-21			
Trim				
Zero	4-9			
Trim the Transmitter	3-19			
Output Trim	3-23			
Scaled Output Trim	3-23			
Sensor Input Trim	3-20			
Transmitter-Sensor Matching	3-21			
Troubleshooting	4-15			
Flowchart	4-15			
LCD Transducer block	4-23			
Reference table	4-15			
Resource Block	4-22			
Types of Modes				
Auto	4-2			
Man	4-2			
Other Types of Modes	4-2			
Out of Service	4-2			
U				
Uncertain				
Limited	4-12			
Man Mode	4-13			
Unicode	4-5			
UNITS_TYPE_#	4-14			
Upper Trim Method	4-17			

*Rosemount and the Rosemount logotype are registered trademarks of Rosemount Inc.
PlantWeb is a registered trademark of one of the Emerson Process Management group of companies.
FOUNDATION is a trademark of the Fieldbus Foundation.
HART is a registered trademark of the HART Communication Foundation.
Lexan and Noryl are registered trademark of General Electric.
WAGO is a registered trademark of Kontakttechnik GmbH, Germany.
All other marks are the property of their respective owners.*

Emerson Process Management

Rosemount Inc.

8200 Market Boulevard
Chanhassen, MN 55317 USA
T (U.S.) 1-800-999-9307
T (International) (952) 906-8888
F (952) 949-7001

www.rosemount.com



Emerson Process Management Temperature GmbH

Frankenstrasse 21
63791 Karlstein
Germany
T 49 (6188) 992 0
F 49 (6188) 992 112

Emerson Process Management Asia Pacific Private Limited

1 Pandan Crescent
Singapore 128461
T (65) 6777 8211
F (65) 6777 0947
AP.RMT-Specialist@emersonprocess.com