

# Principles and Methods of Temperature Measurement

## Course Content

Temperature can be measured via a diverse array of sensors. All of them infer temperature by sensing some change in a physical characteristic. There are four basic types of temperature measuring devices, each of which uses a different principle:

- 1) Mechanical (liquid-in-glass thermometers, bimetallic strips, bulb & capillary, pressure type etc.)
- 2) Thermo-junction (thermocouples)
- 3) Thermoresistive (RTDs and thermistors)
- 4) Radiative (infrared and optical pyrometers)

Each of these is defined and discussed in this learning module.

---

### Mechanical Temperature Measuring devices

#### Principle of Operation

A change in temperature causes some kind of mechanical motion, typically due to the fact that most materials expand with a rise in temperature. Mechanical thermometers can be constructed which use liquids, solids, or even gases as the temperature-sensitive material.

The mechanical motion is read on a physical scale to infer the temperature. The examples include:

- 1) **Liquid-in-glass thermometer**

The most common and well-known thermometer is the liquid-in-glass thermometer.

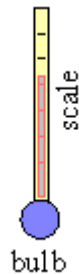

As the temperature rises, the liquid expands, moving up the tube. The scale is calibrated to read temperature directly. Usually, mercury or some kind of alcohol is used for the liquid.

- 2) **Bimetallic strip thermometer**

Two dissimilar metals are bonded together into what is called a bimetallic strip as figured below.

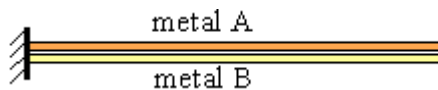

Suppose metal A has a smaller coefficient of thermal expansion than does metal B. As temperature increases, metal B expands more than does metal A, causing the bimetallic strip to curl upwards as sketched.

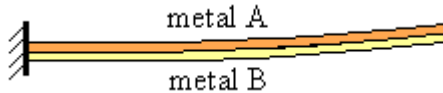

One common application of bimetallic strips is in air-conditioning thermostats, where a bimetallic strip is used as the arm of a switch between electrical contacts. As the room temperature changes, the bimetallic strip bends as discussed above. When the bimetallic strip bends far enough, it makes contact with electrical leads which turn the heat or air conditioning on or off.

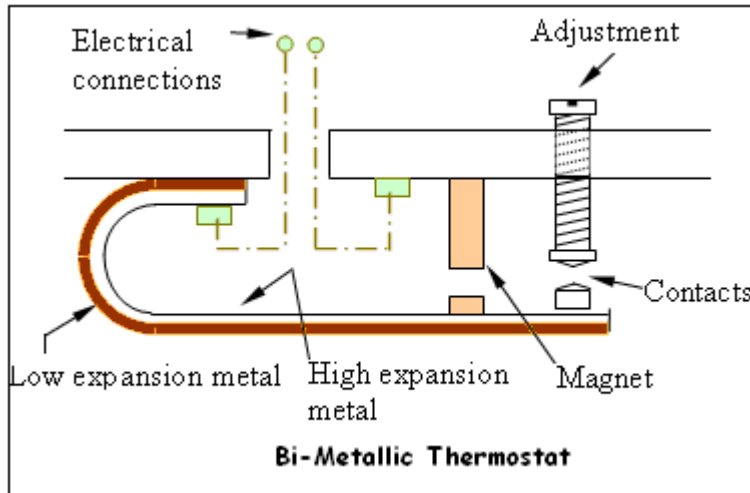

Another common application is for use as oven thermometers or wood burner thermometers. These thermometers consist of a bimetallic strip wound up in a spiral, attached to a dial which is calibrated into a temperature scale.

3) **Sealed Bellows**

The sealed bellows type is filled with a gas, vapor or liquid, which responds to change in temperature by variation in volume and pressure causing expansion or contraction.

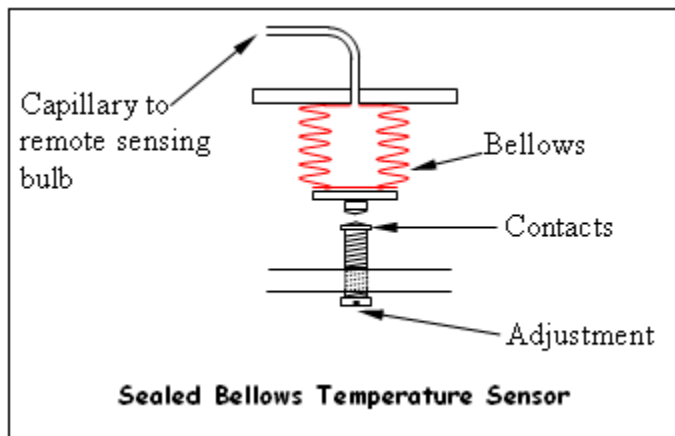

4) **Bulb and Capillary Sensor**

Bulb and capillary elements are used where temperatures are to be measured in ducts, pipes, tanks or similar locations remote from the controller.

The bulb is filled with liquid, gas or refrigerant depending on the temperature range required. Expansion of the fluid in the heated bulb exerts a pressure which is transmitted by the capillary to the diaphragm and there translated into movement.

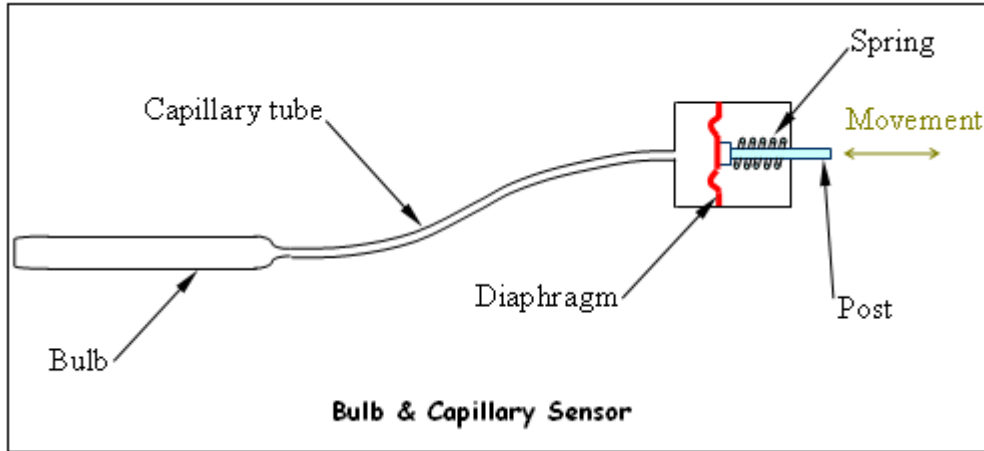

5) **Pressure thermometer**

A pressure thermometer, while still considered mechanical, operates by the expansion of a gas instead of a liquid or solid. (Note: There are also pressure thermometers which use a liquid instead of a gas.)

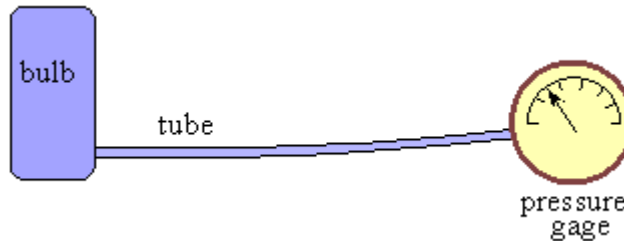

Suppose the gas inside the bulb and tube can be considered an ideal gas. The ideal gas law is  $PV = m R T$

Where

- 1) P is the pressure,
- 2) V is the volume of the gas,
- 3) m is the mass of the gas,
- 4) R is the gas constant for the specific gas (not the universal gas constant), and
- 5) T is the absolute temperature of the gas.

The bulb and tube are of constant volume, so V is a constant. Also, the mass, m, of gas in the sealed bulb and tube must be constant. Hence, the above equation reduces to  $P = kT$ , where k is constant.

A pressure thermometer therefore measures temperature *indirectly* by measuring pressure. The gage is a pressure gage, but is typically calibrated in units of temperature instead.

A common application of this type of thermometer is measurement of outside temperature from the inside of a building. The bulb is placed outside, with the tube running through the wall into the inside. The gage is on the inside. As  $T$  increases outside, the bulb temperature causes a corresponding increase in pressure, which is read as a temperature increase on the gage.

---

## THERMOCOUPLES

A thermocouple is made up of two dissimilar metals, joined together at one end, that produce a voltage (expressed in millivolts) with a change in temperature. The junction of the two metals, called the sensing junction, is connected to extension wires. Any two dissimilar metals may be used to make a thermocouple.

### Principle of Operation

- 1) When two dissimilar metals are connected together, a small voltage called a *thermo-junction voltage* is generated at the junction. This is called the *Peltier effect*.
- 2) If the temperature of the junction changes, it causes voltage to change too, which can be measured by the input circuits of an electronic controller. The output is a voltage proportional to the temperature difference between the junction and the free ends. This is called the *Thompson effect*.
- 3) Both of these effects can be combined to measure temperature. By holding one junction at a known temperature (reference junction) and measuring the voltage, the temperature at the sensing junction can be deduced. The voltage generated is directly proportional to the temperature difference. The combined effect is known as the *thermo-junction effect* or the *Seebeck effect*.

Figure below illustrates a simple thermocouple circuit.

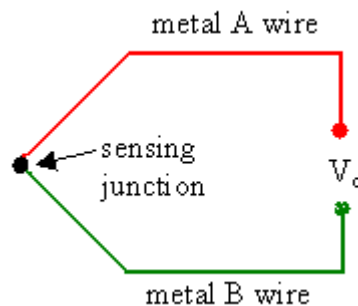

The voltage is measured to infer the temperature. In practical operation, wires A and B are connected to a digital voltmeter (DVM), digital multimeter (DMM), digital data acquisition system, or some other voltage measuring device. If the measuring device has very high input impedance, the voltage produced by the thermo-junction can be measured accurately.

However, the main problem with thermocouple temperature measurement is that wires A and B must connect to the leads of the voltmeter, which are generally made of copper. If neither wire A nor wire B is itself copper, connecting to the DVM creates *two more thermo-junctions!* (Thermocouple metals are typically not the same as those of the DVM leads.) These additional thermo-junctions also produce a thermo-junction voltage, which can create an error when trying to measure the voltage from the sensing junction.

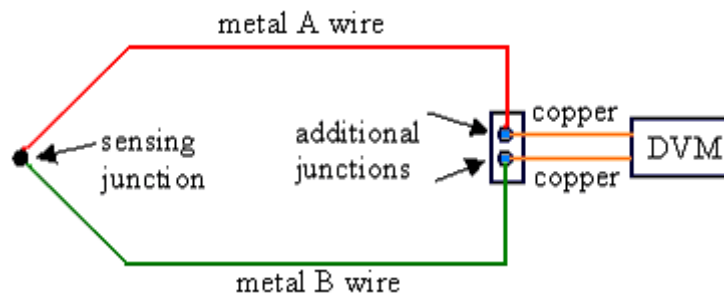

How can this problem be resolved?

One simple solution is to add a fourth thermo-junction, called a *reference junction*, by inserting an additional length of metal A wire into the circuit as sketched below. The reference junction consists of metals A and B as indicated on the sketch.

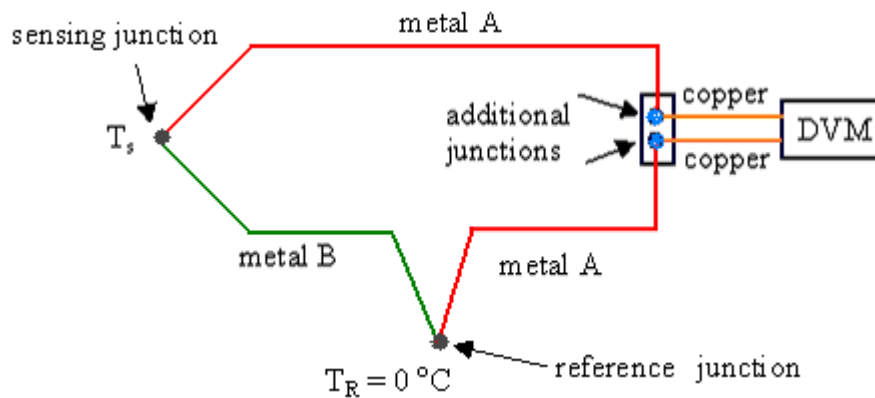

This modified circuit is analyzed as follows:

With this arrangement, there are still two additional thermocouple junctions formed where the compensated thermocouple is connected to the voltmeter (DVM). The two junctions to the DVM are now both between metal A and copper. These two junctions are placed *close together*, and at the *same temperature*, so that their thermo-junction voltages are identical, and cancel each other out. Meanwhile, the new reference junction is placed in a location where the *reference temperature*  $T_R$  is known accurately, typically in an ice-water bath with a fixed temperature of  $T_R = 0^\circ\text{C}$ . If the sensing junction is also at  $0^\circ\text{C}$  ( $T_s = 0^\circ\text{C}$ ), the voltage generated by the sensing junction will be equal and opposite of that generated by the reference junction. Hence,  $V_o = 0$  when  $T_s = 0^\circ\text{C}$ . However, if the sensing junction temperature is not equal to  $T_R$ ,  $V_o$  will be non-zero.

In summary,  $V_o$  is a unique function of the sensor temperature  $T_s$  and the two metals used for the thermocouple. Thus, for known reference temperature and known thermocouple wire materials, output voltage  $V_o$  can be used to measure temperature. This is the fundamental concept of thermocouple usage.

## Thermocouple Materials

Thermocouples may be constructed of several different combinations of materials. The performance of a thermocouple material is generally determined by using that material with platinum. The most important factor to be considered when selecting a pair of materials is the "thermoelectric difference" between the two materials. A significant difference between the two materials will result in better thermocouple

performance. Figure below illustrates the characteristics of the more commonly used materials when used with platinum. For example: Chromel-Constantan is excellent for temperatures up to 2000°F; Nickel/Nickel-Molybdenum sometimes replaces Chromel-Alumel; and Tungsten-Rhenium is used for temperatures up to 5000°F. Some combinations used for specialized applications are Chromel-White Gold, Molybdenum-Tungsten, Tungsten-Iridium, and Iridium/Iridium-Rhodium.

The figure below illustrates the thermocouple material characteristics when used with Platinum.

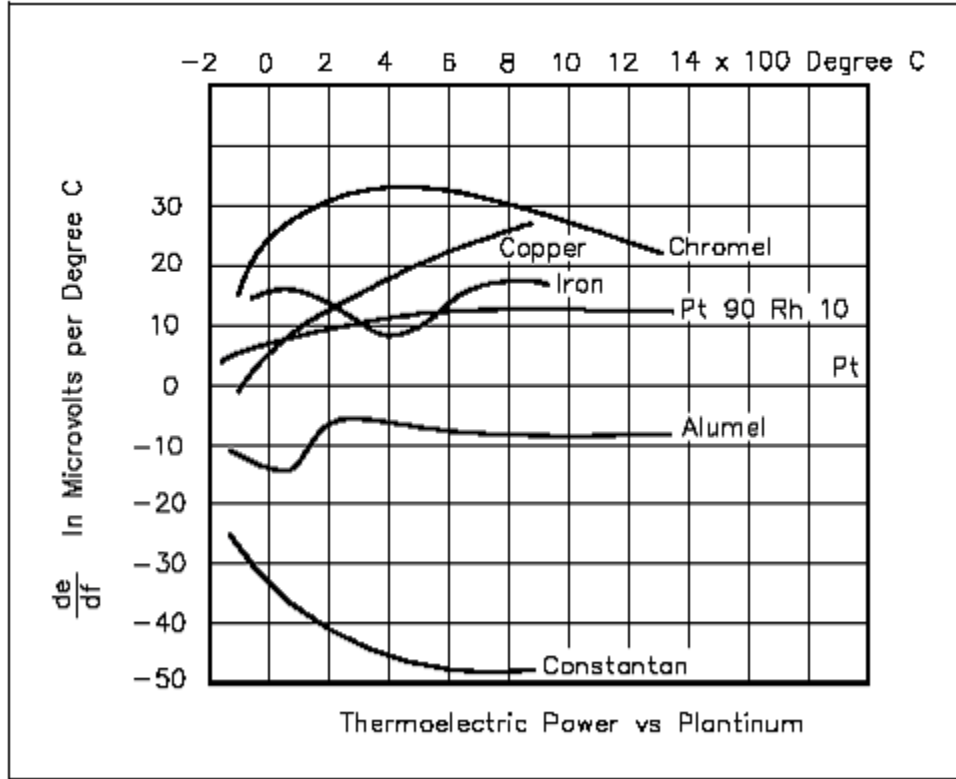

## Characteristics of Thermocouple Types

Of the infinite number of thermocouple combinations, the Instrument Society of America (ISA) recognizes 12. Most of these thermocouple types are known by a single-letter designation; the most common are J, K, T, and E. The compositions of thermocouples are international standards, but the color codes of their wires are different. For example, in the U.S. the negative lead is always red, while the rest of the world uses red to designate the positive lead. Often, the standard thermocouple types are referred to by their trade names. For example,

- 1) A *type K* thermocouple has the color *yellow*, and uses *chromel – alumel*, which are the trade names of the Ni-Cr and Ni-Al wire alloys.
- 2) A *type J* thermocouple has the color *black*, and uses *iron* and *constantan* as its component metals. (Constantan is an alloy of nickel and copper.)
- 3) A *type T* thermocouple has the color *blue*, and uses *copper* and *constantan* as its component metals.
- 4) A *type S* thermocouple uses Pt/Rh-Pt
- 5) A *type E* thermocouple uses Ni/Cr-Con
- 6) A *type N* thermocouple uses Ni/Cr/Si-Ni/Si

Each calibration has a different temperature range and environment, although the maximum temperature varies with the diameter of the wire used in the thermocouple. Variations in the alloy composition and the condition of the junction between the wires are sources of error in temperature measurements. The standard error of thermocouple wire varies from  $\pm 0.8$  °C to  $\pm 4.4$  °C, depending on the type of thermocouple used. The K type thermocouple is recommended for most general purpose applications. It offers a wide temperature range, low standard error, and has good corrosion resistance. In fact, many digital multimeters (DMMs) can measure temperature by plugging in a type K thermocouple with standard connections.

The voltage produced by a thermocouple varies *almost*, but not exactly, linearly with temperature. Therefore, there are no simple equations to relate thermocouple voltage to temperature. Rather, voltage is tabulated as a function of temperature for the various standard thermocouples. In order to convert the millivolt reading to its corresponding temperature, you must refer to tables like the one shown below. These tables can be obtained from the thermocouple manufacturer, and they list the specific temperature corresponding to a series of millivolt readings. *By convention, the reference temperature for thermocouple tables is 0°C.*

**Temperature V/s Voltage Reference Table for Type J**

Temperature (°C)	voltage (mV)
0.0	0.000
10.0	0.507
20.0	1.019
30.0	1.537
40.0	2.059
50.0	2.585
60.0	3.116
70.0	3.650
80.0	4.187
90.0	4.726
100.0	5.269

---

**Choosing a thermocouple type**

Because thermocouples measure in wide temperature ranges and can be relatively rugged, they are very often used in industry. The following criteria are used in selecting a thermocouple:

- 1) Temperature range

- 2) Chemical resistance of the thermocouple or sheath material
- 3) Abrasion and vibration resistance
- 4) Installation requirements (may need to be compatible with existing equipment; existing holes may determine probe diameter).

**Standard Specifications**

**Diameters:** Standard diameters: 0.010", 0.020", 0.032", 0.040", 1/16", 1/8", 3/16", and 1/4" with two wires.

**Length:** Standard thermocouples have 12 inch immersion lengths. Other lengths are custom made.

**Sheaths:** 304 stainless steel and Inconel are standard.

**Insulation:** Magnesium Oxide is standard. Minimum insulation resistance wire to wire or wire to sheath is 1.5megohms at 500 volts dc in all diameters.

**Calibration:** Iron-Constantan (J), *chromel – alumel* (K), Copper-Constantan (T), and Chromel-Constantan (E) are standard calibrations.

**Bending:** Easily bent and formed. Bend radius should be not less than twice the diameter of the sheath.

**Polarity:** In the thermocouple industry, standard practice is to color the negative lead red.

**Thermocouple Junctions:**

Sheathed thermocouple probes are available with one of three junction types: grounded, ungrounded or exposed.

**Grounded Junction-** In this type, the thermocouple wires are physically attached to the inside of the probe wall. This results in good heat transfer from the outside, through the probe wall to the thermocouple junction. The grounded junction is recommended for the measurement of static or flowing corrosive gas and liquid temperatures and for high pressure applications. The junction of a grounded thermocouple is welded to the protective sheath giving faster response than the ungrounded junction type.

**Ungrounded Junction-** In an underground probe, the thermocouple junction is detached from the probe wall. Response time is slowed down from the grounded style, but the ungrounded offers electrical isolation of 1.5 M1/2 at 500 Vdc in all diameters. An ungrounded junction is recommended for measurements in corrosive environments where it is desirable to have the thermocouple electronically isolated from and shielded by the sheath. The welded wire thermocouple is physically insulated from the thermocouple sheath by MgO powder (soft).

**Exposed Junction-** In the exposed junction style, the thermocouple protrudes out of the tip of the sheath and is exposed to the surrounding environment. This type offers the best response time, but is limited in use to non-corrosive and non-pressurized applications. The junction extends beyond the protective metallic sheath to give accurate fast response. The sheath insulation is sealed where the junction extends to prevent penetration of moisture or gas which could cause errors.

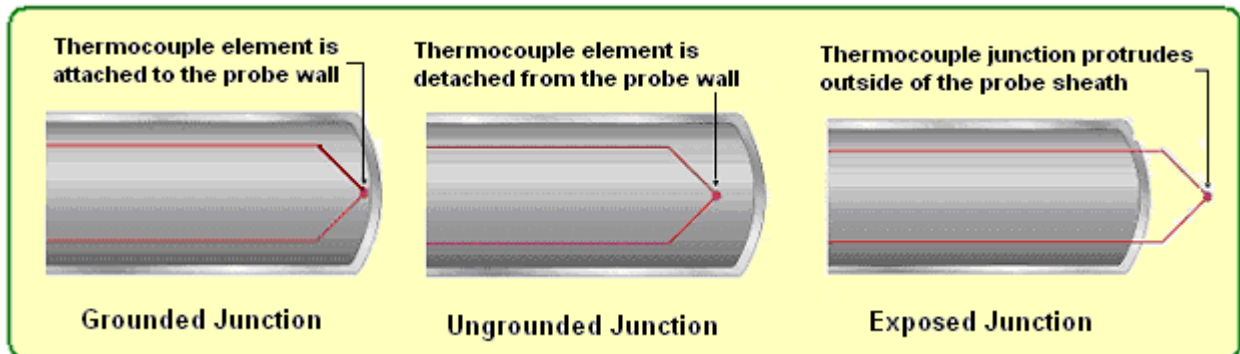



In summary, the exposed junction provides the quickest response time followed by grounded junction. Temperature measurement decisions can make or break the expected results of the process. Choosing the correct sensor for the application might be a difficult task, but processing that measured signal is also very critical.

## Thermocouple Laws

### First some notation:

Let  $T_1$  be the temperature of bath 1, and  $T_2$  be the temperature of bath 2.

Let  $V_{1-R}$  be defined as the voltage produced by a thermocouple at temperature  $T_1$  when a proper reference junction at temperature  $T_R$  is used ( $T_R = \text{reference temperature} = 0^\circ\text{C}$ ).  $V_{1-R}$  is the voltage listed in the thermocouple tables at temperature  $T_1$ .

Let  $V_{1-2}$  be defined as the difference in voltage between  $V_{1-R}$  and  $V_{2-R}$ ,

$$V_{1-2} = V_{1-R} - V_{2-R}$$

### Sign convention:

Negative sign errors can be problematic when working with these equations, if one is not consistent.

By convention, the thermocouple tables are constructed such that *higher* temperature yields *higher* thermo-junctive voltage.

In other words, it is always be assumed that the two thermocouple wires (let's call them wire A and wire B) are connected to the voltmeter in such a way that the voltage is *positive* when the temperature being measured is *greater* than the reference temperature. Likewise, the voltage is *negative* when the temperature being measured is *less* than the reference temperature.

Since the standard reference temperature for thermocouple tables is  $0^\circ\text{C}$ , positive temperatures in units of  $^\circ\text{C}$  yield positive thermo-junctive voltages, and negative temperatures in units of  $^\circ\text{C}$  yield negative thermo-junctive voltages.

Note that if the wires are connected the *opposite* way to the voltmeter, the voltages will of course be of opposite sign.

There are three laws or rules that apply to thermocouples:

#### 1) Law of intermediate metals

“A third (intermediate) metal wire can be inserted in series with one of the wires without changing the voltage reading (provided that the two new junctions are at the same temperature)”.

Consider the setup below, where a rectangle around a thermo-junction indicates a constant temperature bath (e.g. a pot of boiling water or an ice-water bath).

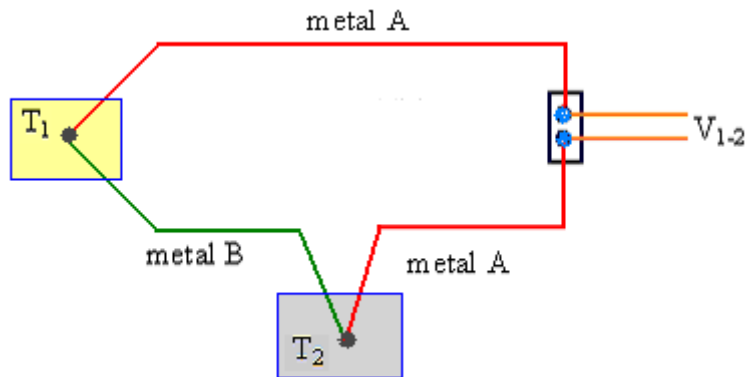

The law of intermediate metals states that the voltage reading,  $V_{1-2}$  does not change if one adds a third (intermediate) wire in line with any of the wires in the circuit, as sketched below:

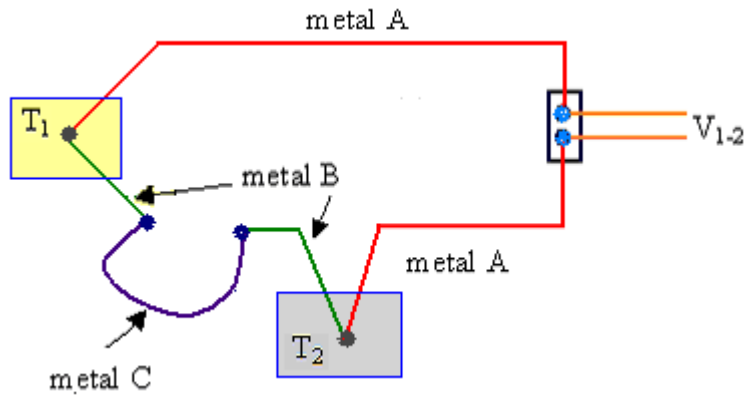

In the above diagram, it is assumed that both of the new junctions (between metal B and metal C) are at the same temperature, i.e. ambient temperature,  $T_a$ .

One can easily see that the law of intermediate metals must hold here, since whatever voltage is generated at one of the new junctions is exactly canceled by an equal and opposite voltage generated at the other new junction.

Likewise, metal C can be inserted anywhere else in the circuit without any effect on the output voltage, provided that the two new junctions are at the same temperature. For example, consider the following modified circuit:

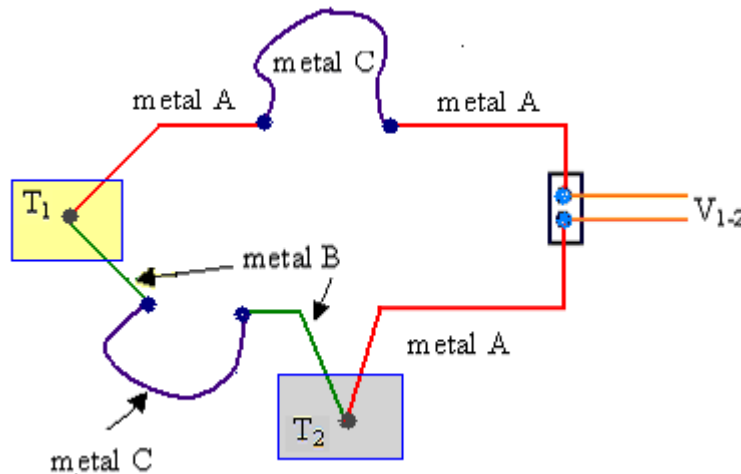

Again, if the two new junctions (this time between metals A and C) are at the same temperature, there is no net effect on the output voltage.

## 2) Law of intermediate temperatures

*“If identical thermocouples measure the temperature difference between  $T_1$  and  $T_2$ , and the temperature difference between  $T_2$  and  $T_3$ , then the sum of the corresponding voltages  $V_{1-2} + V_{2-3}$  must equal the voltage  $V_{1-3}$  generated by an identical thermocouple measuring the temperature difference between  $T_1$  and  $T_3$ .”*

Mathematical statement of the law of intermediate temperatures:

$$V_{1-3} = V_{1-2} + V_{2-3} \text{ for any three temperatures, } T_1, T_2, \text{ and } T_3.$$

Consider the setup below, where six thermo-junctions are shown, two in each constant temperature bath. Note: To avoid clutter in the diagram, the copper leads of the DVM are no longer shown. Also, for brevity, letters A and B indicate metal A and metal B, two different types of thermocouple wires.

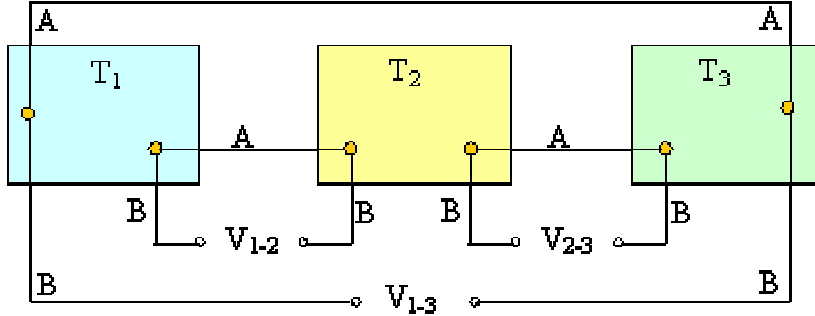

By the notation convention adopted here,

$$V_{1-3} = V_{1-R} - V_{3-R},$$

which can be written as

$$V_{1-3} = (V_{1-R} - V_{2-R}) + (V_{2-R} - V_{3-R})$$

But since (also by definition)

$$V_{1-2} = V_{1-R} - V_{2-R}, \text{ and}$$

$$V_{2-3} = V_{2-R} - V_{3-R},$$

it follows directly that

$$V_{1-3} = V_{1-2} + V_{2-3}.$$

3) **Law of additive voltages**

*“For a given set of 3 thermocouple wires, A, B, and C, all measuring the same temperature difference  $T_1 - T_2$ , the voltage measured by wires A and C must equal the sum of the voltage measured by wires A and B and the voltage measured by wires B and C”.*

Consider the setup below, where six thermo-junctions are shown, three in constant temperature bath  $T_1$ , and three in constant temperature bath  $T_2$ . As above, letters A, B, and C indicate different types of thermocouple wires.

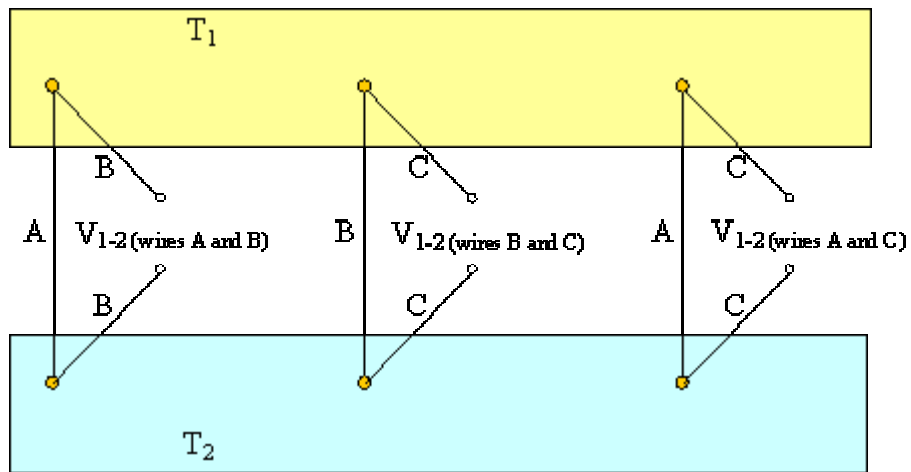

The law of additive voltages can be stated mathematically as:

$$V_{1-2} \text{ (wires A and C)} = V_{1-2} \text{ (wires A and B)} + V_{1-2} \text{ (wires B and C)}$$

Or, rearranging in terms of voltage *differences*,

$$V_{1-2} \text{ (wires A and B)} = V_{1-2} \text{ (wires A and C)} - V_{1-2} \text{ (wires B and C)}$$

## Thermopile

A *thermopile* is defined as several thermocouples connected in series. For example, a thermopile with three sensing junctions is shown below:

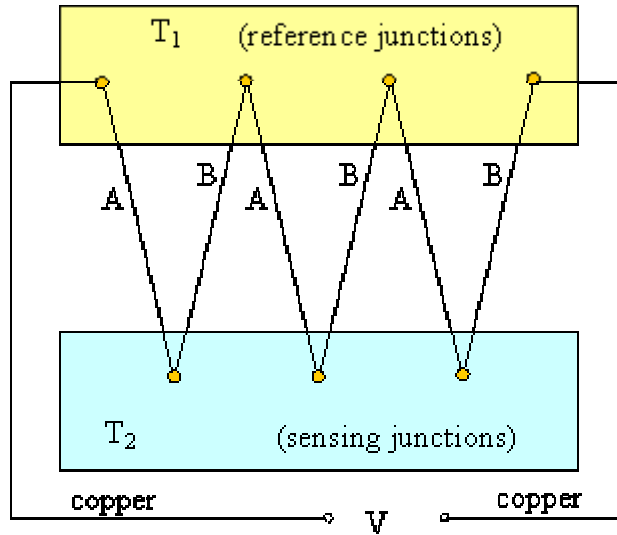

As  $T_2$  is increased, the output voltage increases significantly. The advantage of a thermopile (as compared to just one sensing junction) is *increased sensitivity*.

Here, the voltage output is three times that which is generated by just one thermocouple under otherwise identical conditions, as sketched below:

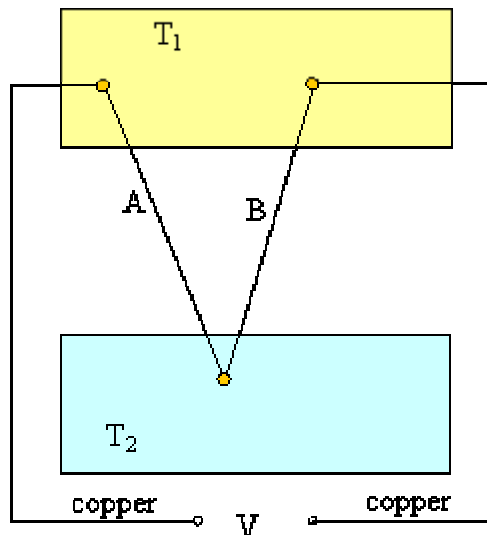

With enough sensing junctions, a thermopile can actually generate a useful voltage. For example, *thermopiles are often used to control shut-off valves in furnaces.*

---

## Thermo-resistive Temperature Measuring Devices

A change in temperature causes the electrical resistance of a material to change. The resistance change is measured to infer the temperature change.

There are two types of thermo-resistive measuring devices:

- 1) Resistance temperature detectors (RTD) and
- 2) Thermistors

## Resistance Temperature Detectors

A resistance temperature detector (abbreviated RTD) is basically either a long, small diameter metal wire wound in a coil or an etched grid on a substrate, much like a strain gage. Platinum is the most common metal used for RTDs.

### Principle of Operation

Resistance Temperature Detectors (RTD) operates on the principle that the electrical resistance of a metal changes predictably in an essentially linear and repeatable manner with changes in temperature. RTD have a positive temperature coefficient (resistance increases with temperature). The resistance of the element at a base temperature is proportional to the length of the element and the inverse of the cross sectional area.

A typical electrical circuit designed to measure temperature with RTDs actually measures a change in *resistance* of the RTD, which is then used to calculate a change in temperature. The resistance of an RTD increases with increasing temperature, just as the resistance of a strain gage increases with increasing strain.

---

### Bridge Circuit Construction

Figure below shows a basic bridge circuit which consists of three known resistances,  $R_1$ ,  $R_2$ , and  $R_3$  (variable), an unknown variable resistor  $R_x$  (RTD), a source of voltage, and a sensitive ammeter.

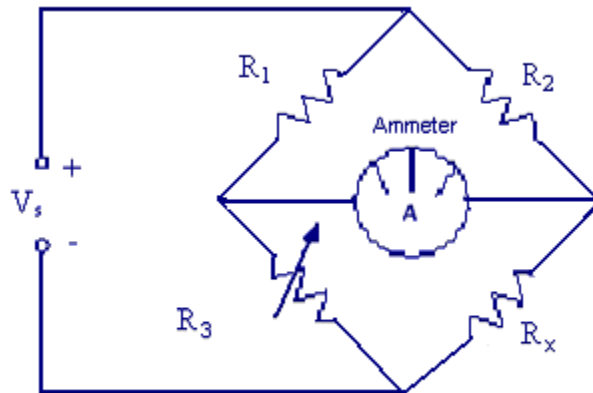

**Bridge Circuit**

Resistors R1 and R2 are the ratio arms of the bridge. They ratio the two variable resistances for current flow through the ammeter. R3 is a variable resistor known as the standard arm that is adjusted to match the unknown resistor. The sensing ammeter visually displays the current that is flowing through the bridge circuit. Analysis of the circuit shows that when R3 is adjusted so that the ammeter reads zero current, the resistance of both arms of the bridge circuit is the same. The relationship of the resistance between the two arms of the bridge can be expressed as

$$\frac{R_1}{R_3} = \frac{R_2}{R_x}$$

Since the values of R1, R2, and R3 are known values, the only unknown is Rx. The value of Rx can be calculated for the bridge during an ammeter zero current condition. Knowing this resistance value provides a baseline point for calibration of the instrument attached to the bridge circuit. The unknown resistance, Rx, is given by

$$R_x = \frac{R_2 R_3}{R_1}$$

### RTD Bridge Circuit Operation

One simple circuit is the quarter bridge Wheatstone bridge circuit, here called a **two-wire RTD bridge circuit**.

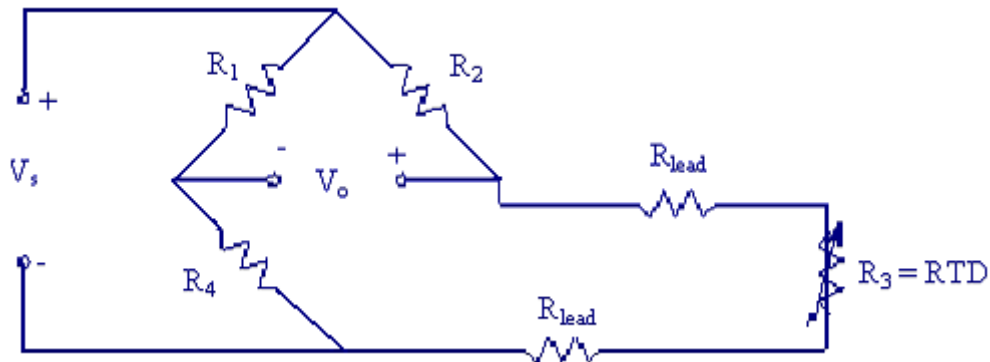

R<sub>lead</sub> represents the resistance of one of the wires (called *lead wires*) that run from the bridge to the RTD itself. Lead resistance was of no concern in strain gage circuits because R<sub>lead</sub> remained constant at all times.

For RTD circuits, however, some portions of the lead wires are exposed to changing temperatures. Since the resistance of metal wire changes with temperature, R<sub>lead</sub> changes with T, which can cause errors in the measurement. This error can be non-trivial - *changes in lead resistance may be misinterpreted as changes in RTD resistance*. Furthermore, there are two lead wires in the two-wire RTD bridge circuit shown above, which doubles the error. A clever circuit designed to eliminate the lead wire resistance error is called a *three-wire RTD bridge circuit*. The three-wire RTD bridge circuit is shown below.

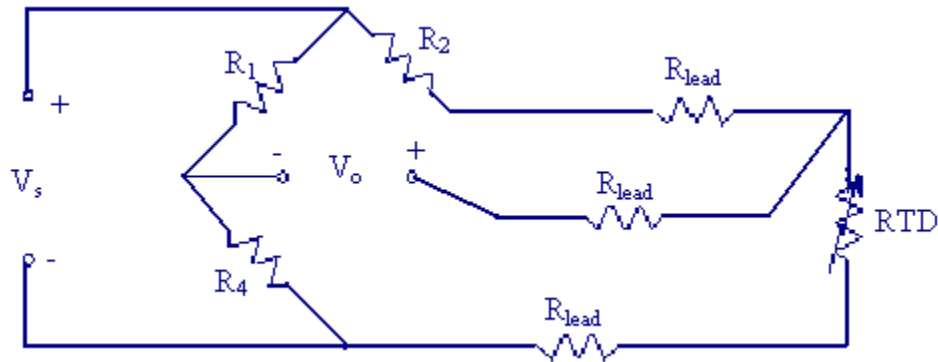

It is still a quarter bridge circuit, since only one of the four bridge resistors has been replaced by the RTD. However, one of the lead wires has been placed on the R<sub>2</sub> leg of the bridge instead of the R<sub>3</sub> leg.

To analyze this circuit, assume that R<sub>1</sub> = R<sub>4</sub>, and R<sub>2</sub> = R<sub>3</sub> initially, when the bridge is balanced.

Recall the general formula for a Wheatstone bridge:

$$V_o = V_s \frac{R_3 R_1 - R_4 R_2}{(R_2 + R_3)(R_1 + R_4)}$$

Notice that R<sub>3</sub> and R<sub>2</sub> have opposite signs in the above equation. So, if the lead wire resistance in leg 2 (top) and that in leg 3 (bottom) are the *same*, *the lead resistances cancel each other out*, with no net effect on the output voltage, thus eliminating the error.

What about the third lead resistance, R<sub>lead</sub> of the middle wire? Well, since V<sub>o</sub> is measured with a nearly infinite impedance device, *no current flows in the middle lead wire*, so its resistance does not affect anything!

The following re-drawn equivalent circuit may help explain why the lead resistances cancel out:

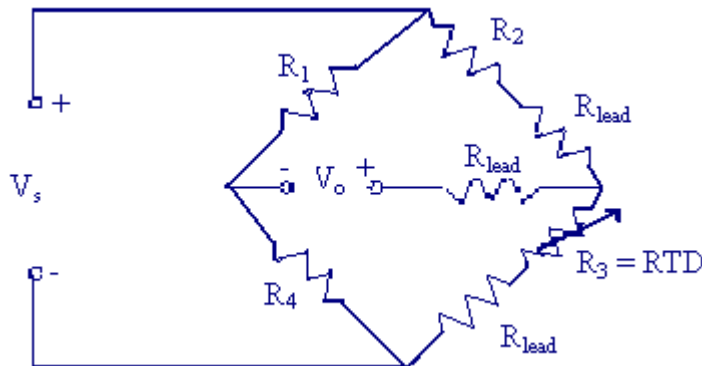

In the above diagram, it is clear that if R<sub>lead</sub> changes equally in leg 2 and leg 3 of the bridge, its effect cancels out.

### RTD Materials & Construction

RTD acts somewhat like an electrical transducer, converting changes in temperature to voltage signals by the measurement of resistance. The metals that are best suited for use as RTD sensors are pure metals

or certain alloys of uniform quality that increase in resistance as temperature increases and conversely decrease in resistance as temperature decreases. Only a few metals have the properties necessary for use in RTD elements. Common materials used in RTD sensor are BALCO wire, Copper, Platinum.

- 1) **BALCO** - A sensor constructed using a BALCO wire is an annealed resistance alloy with a nominal composition of 70 percent nickel and 30 percent iron. A BALCO 500-ohm resistance element provides a relatively linear resistance variation from  $-40$  to  $250^{\circ}\text{F}$ . The sensor is a low-mass device and responds quickly to changes in temperature. When 1000 ohms is measured across the BALCO element, the temperature is approximately  $70^{\circ}\text{F}$ . As the temperature increases, the resistance changes 2.2 ohms per  $1^{\circ}\text{F}$ . This is called a Temperature Coefficient of Resistance Curve (TCR Curve). In a BALCO, as the resistance has direct relationship with temperature i.e. as temperature increases, the resistance increases proportionally. The usual range of temperature measurement with BALCO is  $-40^{\circ}$  to  $240^{\circ}\text{F}$ .
- 2) **Platinum** - RTD sensors using platinum material exhibit linear response and stable over time. In some applications a short length of wire is used to provide a nominal resistance of 100 ohms. However, with a low resistance value, element self-heating and sensor lead wire resistance can effect the temperature indication. With a small amount of resistance change of the element, additional amplification must be used to increase the signal level. Platinum film sensor on an insulating base provides high resistance to the tune of 1000 ohms at  $74^{\circ}\text{F}$ . With this high resistance, the sensor is relatively immune to self-heating and responds quickly to changes in temperature. RTD elements of this type are common.

These metals are best suited for RTD applications because of their linear resistance-temperature characteristics (as shown in figure below), their high coefficient of resistance, and their ability to withstand repeated temperature cycles. The coefficient of resistance is the change in resistance per degree change in temperature, usually expressed as a percentage per degree of temperature. The material used must be capable of being drawn into fine wire so that the element can be easily constructed.

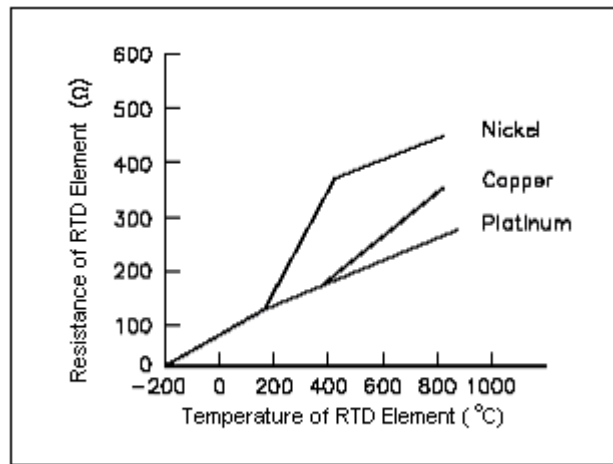

**Electric Resistance-Temperature Curves**

Copper and nickel versions operate at lower temperature ranges and are less expensive than platinum. Platinum is the most versatile material because of its wide temperature range ( $-200^{\circ}\text{C}$  to  $850^{\circ}\text{C}$ ), excellent repeatability, stability, and resistance to chemicals and corrosion.

RTD elements are usually long, spring-like wires surrounded by an insulator and enclosed in a sheath of metal. Figure below shows the internal construction of an RTD.



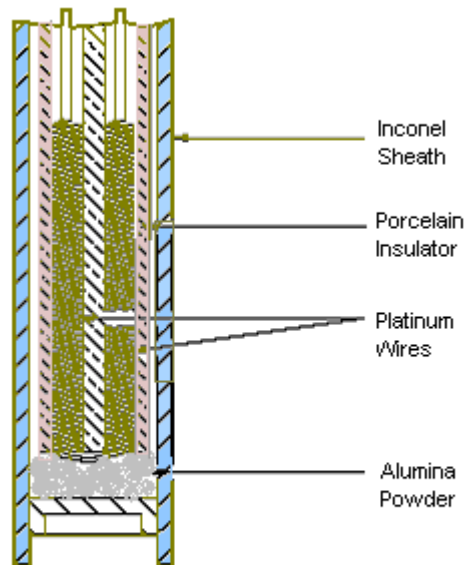

**Internal Construction of Typical RTD**

This particular design has a platinum element that is surrounded by a porcelain insulator. The insulator prevents a short circuit between the wire and the metal sheath. Inconel, a nickel-iron-chromium alloy, is normally used in manufacturing the RTD sheath because of its inherent corrosion resistance. When placed in a liquid or gas medium, the Inconel sheath quickly reaches the temperature of the medium. The change in temperature will cause the platinum wire to heat or cool, resulting in a proportional change in resistance.

**Advantages:** Linear resistance with temperature, good stability, wide range of operating temperature

Interchangeable over wide temperature range

**Disadvantages:** Small resistance change with temperature, responses may be slower, subject to self heating, transmitter or three to four wire leads required for lead resistance compensation, external circuit power required

#### **Additional facts**

- 1) RTD's are commonly used in sensing air and liquid temperatures in pipes and ducts, and as room temperature sensors. The resistance of RTD elements varies as a function of temperature. Some elements exhibit large resistance changes, linear changes, or both over wide temperature ranges.
- 2) Varying voltage across the sensor element determines the resistance of the sensor. The power supplied for this purpose can cause the element to heat slightly and can create an inaccuracy in the temperature measurement. Reducing supply current or by using elements with higher nominal resistance can minimize the self-heating effect.
- 3) Some RTD element resistances are as low as 100 ohms. In these cases, the resistance of the lead wires connecting the RTD to the controller may add significantly to the total resistance of the connected RTD, and can create an error in the measurement of the temperature. For instance, a sensor placed 25 feet from the controller has a copper control wire of  $25 \times 2 = 50$  feet. If a control wire has a DC resistance of 6.39 ohms/ft, the 50 feet of wire shall have a total dc resistance of 0.319 ohms. If the sensor is a 100-ohm platinum sensor with a temperature coefficient of 0.69 ohms per degree F, the 50 feet of wire will introduce an error of 0.46 degrees F. If the sensor is a 3000-ohm platinum sensor with a temperature coefficient of 4.8 ohms per degree F, the 50 feet of wire will introduce an error of 0.066 degrees F.

Therefore lesser is the resistance of sensor element, higher shall be the likelihood of error. Significant errors can be removed by adjusting a calibration setting on the controller, or, if the

controller is designed for it, a third wire can be run to the sensor and connected to a special compensating circuit designed to remove the lead length effect on the measurement.

---

## Thermistors

Thermistors are temperature sensitive semiconductors that exhibit a large change in resistance over a relatively small range of temperature. There are two main types of thermistors, positive temperature coefficient (PTC) and negative temperature coefficient (NTC). NTC thermistors exhibit the characteristic of resistance falling with increasing temperature. These are most commonly used for temperature measurement.

A *thermistor* is similar to an RTD, but a *semiconductor material* is used instead of a metal. A thermistor is a *solid state* device and has larger *sensitivity* than does an RTD. Unlike RTD's, the temperature-resistance characteristic of a thermistor is non-linear, and cannot be characterized by a single coefficient. Furthermore, unlike RTDs, the resistance of a thermistor *decreases* with increasing temperature.

Thermistors cannot be used to measure high temperatures compared to RTDs. In fact, the maximum temperature of operation is sometimes only 100 or 200°C.

Manufacturers commonly provide resistance-temperature data in curves, tables or polynomial expressions. Linearizing the resistance-temperature correlation may be accomplished with analog circuitry, or by the application of mathematics using digital computation. A typical thermistor circuit is shown below.

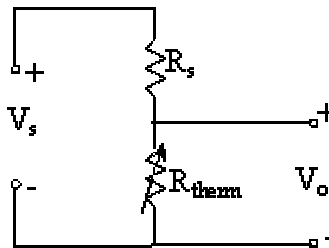

From the circuit diagram, it is clear that this is a simple voltage divider.  $R_s$  is some fixed (supply) resistor.  $R_s$  and the supply voltage,  $V_s$ , can be adjusted to obtain the desired range of output voltage  $V_o$  for a given range of temperature.

**Advantages:** Large resistance change with temperature, rapid response time, good stability, High resistance eliminates difficulties caused by lead resistance, Low cost and interchangeable

**Disadvantages:** Non-linear, limited operating temperature range, may be subjected to inaccuracy due to overheating, current source required

---

## Radiative Temperature Measuring Devices

Two types of radiative measuring devices are

- 1) Infrared pyrometers and
- 2) Optical pyrometers.

### Infrared Pyrometer

Infrared temperature sensors also known as pyrometers or non-contact temperature sensors are used to measure the temperature of an object without contact. This is different from most temperature measurement devices, which require direct contact with the measured media. Non-contact methods of

temperature measurement are advantageous when contact methods are impossible or impractical, such as when the target is inaccessible or so hot that contact devices will not survive.

### Principle of Operation

Infrared temperature sensors use the principle that any object emits an amount of energy that is a function of its temperature. This function dictates that as the temperature of an object rises, so does the amount of energy it emits.

*“An infrared temperature sensor determines temperature by measuring the intensity of energy given off by an object.”*

Calculating the temperature of an object from the measured emitted energy seems straightforward. However, the quantity of energy emitted by an object is not a function of temperature only. The other variable besides temperature that affects emissions is emissivity. From a practical standpoint, emissivity is an inherent surface characteristic that can fluctuate with changes to surface oxidation, texture, composition, and microstructure. When it comes to non-contact temperature measurement all that is really important is knowing, that emissivity is a correction factor greater than 0 but less than 1 that enables infrared temperature sensors to output the correct surface temperature.

#### Mathematical statement of Infrared Temperature Measurement:

The amount of energy a surface emits is a function of temperature and emissivity, therefore to correctly determine surface temperature from a measurement of emitted energy, it is imperative to know something about fundamentals of radiation and surface’s emissivity. The fundamental equation for radiation from a body is the **Stefan-Boltzmann equation**,

$$E = \epsilon\sigma T^4 .$$

where

E is the emissive power radiated per unit area (units of W/m<sup>2</sup>).

ε is the emissivity, defined as the fraction of blackbody radiation emitted by an actual surface. The emissivity must lie between 0 and 1, and is dimensionless. Its value depends greatly on the type of surface. A blackbody has an emissivity of exactly 1.

σ is the Stefan-Boltzmann constant,

$$\sigma = 5.669 \times 10^{-8} \frac{W}{m^2K^4} .$$

T is the *absolute* temperature of the surface of the object (units of K). The following is a list of the emissivity of several common surfaces:

surface	emissivity, ε
aluminum (anodized)	0.84
aluminum (polished)	0.03
asphalt pavement	0.85 to 0.93
glass	0.62 to 0.95
human skin	approx. 0.95
water (deep)	0.95 to 0.96

The emissivity of other materials can be found in heat transfer textbooks. Once sufficient information about the surface's emissivity is obtained, the temperature sensor can be programmed to compensate for emissivity.

## Calibration of Infrared Temperature Measurement

The challenge that perplexes manufacturers and users of infrared temperature sensors is definitively quantifying emissivity. Some surfaces have a predictable emissivity; others have an emissivity that will change significantly with no discernable pattern. Experience has sorted out which surfaces are easy to measure and which are difficult. With that, different types of non-contact temperature sensors have been developed that eliminate, or at least reduce, errors caused by emissivity variations.

An infrared pyrometer infers the temperature of a hot surface by measuring the temperature of a detector inside a detector chamber as shown below:

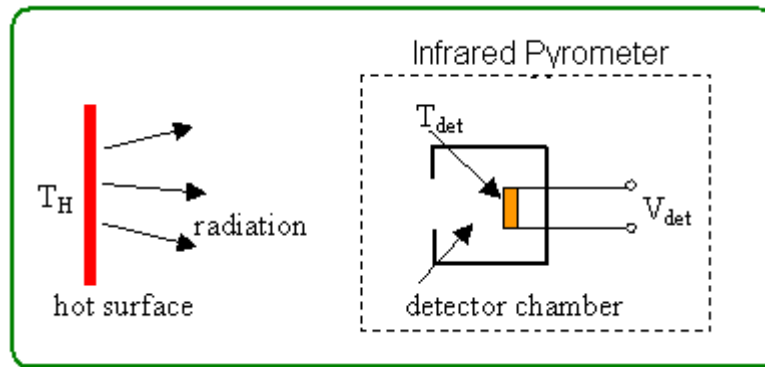

The detector itself is usually a thermopile. It measures  $T_{det}$ , the temperature of the detector inside the chamber.  $T_{ind}$  is the *indicated* temperature, which is calculated from  $T_{det}$ , from the known geometry and the radiation equations.  $T_{ind}$  is calibrated as a function of  $T_H$  for a body of some assumed emissivity.

The instrument is set up such that  $T_{ind}$  is a function of the voltage output. The instrument typically displays a temperature, i.e.  $T_{ind}$ , rather than voltage  $V_{det}$ .

$T_{ind}$  can be thought of as an *uncorrected* estimate of  $T_H$ , since the emissivity of the object may not be the same as that assumed by the infrared pyrometer. In other words, if the actual emissivity of the object is not the same as the assumed emissivity,  $T_{ind}$  will be incorrect.

To correct for the actual emissivity of the object,

$$T_H = \left( \frac{\epsilon_{\text{assumed}}}{\epsilon_{\text{actual}}} \right)^{1/4} T_{\text{ind}}$$

In the above equations, **absolute temperatures** must be used!

## Type of Infrared Temperature Sensors

Infrared temperature sensors fall into one of three categories: single-wavelength, dual wavelength and multi-wavelength.

- 1) Single wavelength temperature sensors, also referred to as single-color temperature sensors, measure all of the energy emitted from a target at one wavelength and calculate the average temperature of the measured area. They require that the target emissivity be relatively constant, or

else error is introduced. Single-wavelength temperature sensors are appropriate for measuring an unobstructed target of constant emissivity.

- 2) Dual-wavelength temperature sensors, also known as two-color or ratio pyrometers, measure the energy emitted from a target at two different wavelengths, take a ratio of the energies, and calculate the temperature. Different from single-wavelength sensors, dual wavelength sensors tend to measure the hottest point in the target area and are less sensitive to emissivity variations. However, severe emissivity variations still introduce error. Dual wavelength temperature sensors are recommended for applications with intervening media such as dirty optics, scale, steam, dust, or water spray. Also, they are appropriate for targets with low or varying emissivity and situations with a partially filled field of view caused by mechanical obstructions or a small target.
- 3) Multi-wavelength sensors use sophisticated electronics to combine signals measured from multiple wavelengths and then calculate the temperature of surfaces with dramatic, yet repeatable, variations in emissivity. Multi wavelength sensors provide the same benefits of a dual-wavelength sensor, but are recommended for non-grey body materials like aluminum, copper, zinc, and stainless steel.

Once the most appropriate type of sensor has been chosen considering the emissivity characteristics of the measured target, the rest of the challenge is selecting a sensor package appropriate for the sensor's operating environment and adjusting for other potential causes of error. Operating conditions to consider when selecting a sensor package include ambient temperature, cleanliness, humidity, electromagnetic radiation, atmosphere, and accessibility. Other causes of error are those conditions that artificially either add to or subtract from the amount of energy transmitted from the target to the sensor. Such sources include background energy that is reflected off of a surface into the sensor, mechanical obstructions that block emitted energy, and windows, thin films, or intervening media that interfere with specific wavelengths.

---

## Optical Pyrometer

An optical pyrometer is useful for measuring very high temperatures (even flames). The optical pyrometer uses an infrared radiation-sensitive sensor, e.g. a photodiode or a photoresistor, to compare the radiation from the unknown with that of the radiation from an internal incandescent source. The accuracy of the optical pyrometer is very much a function of the emissivity of the device that is radiating the heat. The obvious advantage in using an optical pyrometer at very high temperatures is that the measurement is non-contacting.

This approach is very expensive, and due to the variability in emissivity of many physical bodies, it is not very accurate. However, for making non-contact measurements on very high temperature bodies such as molten glass and molten steel, the optical pyrometer excels.

Basic Characteristics are as follows:

- Infrared Radiation-sensitive
- Photodiode or photoresistor
- Accuracy= f{emissivity}
- Useful @ very high temperatures
- Non-contacting
- Very expensive
- Not very accurate

---

## Summarizing

Two most common type of temperature sensors are Thermocouples and RTD's. Although these sensors have overlapping temperature ranges, each has certain application-dependent advantages. These are summarized in below.

<b>Temperature Sensor Selection Guide</b>		
	<b>RTD</b>	<b>Thermocouple</b>
<b>Temperature Range</b>	-200°C to 850°C -328°F to 1562°F	-190°C to 1821°C -310°F to 3308°F
<b>Accuracy</b>	±0.001°F to 0.1°F	±1°F to 10°F
<b>Response Time</b>	Moderate	Fast
<b>Stability</b>	Stable over long periods <0.1% error/5 yr.	Not as stable 1°F error/yr.
<b>Linearity</b>	Best	Moderate
<b>Sensitivity</b>	High sensitivity	Low sensitivity

An RTD is the sensor of choice when sensitivity and application flexibility are the most important criteria. When it comes to component cost an RTD is more expensive than a thermocouple.

\*\*\*\*\*