

Operating Instructions

Ultrasonic sensor for continuous level measurement

VEGASON 61

4 ... 20 mA/HART - two-wire



Document ID: 28775



VEGA

Contents

1	About this document	
1.1	Function	4
1.2	Target group	4
1.3	Symbolism used	4
2	For your safety	
2.1	Authorised personnel	5
2.2	Appropriate use	5
2.3	Warning about incorrect use	5
2.4	General safety instructions	5
2.5	Safety label on the instrument	5
2.6	CE conformity	5
2.7	Fulfillment of NAMUR recommendations	6
2.8	Safety instructions for Ex areas	6
2.9	Environmental instructions	6
3	Product description	
3.1	Configuration	7
3.2	Principle of operation	8
3.3	Operation	8
3.4	Packaging, transport and storage	9
4	Mounting	
4.1	General instructions	10
4.2	Mounting instructions	11
5	Connecting to power supply	
5.1	Preparing the connection	17
5.2	Connection procedure	18
5.3	Wiring plan, single chamber housing	19
5.4	Wiring plan, double chamber housing	21
5.5	Wiring plan - version IP 66/IP 68 (1 bar)	23
5.6	Switch-on phase	23
6	Set up with the display and adjustment module PLICSCOM	
6.1	Short description	24
6.2	Insert display and adjustment module	24
6.3	Adjustment system	25
6.4	Setup steps	26
6.5	Menu plan ultrasonic sensor	31
6.10	Saving the parameter adjustment data	33
7	Set up with PACTware and other adjustment programs	
7.1	Connect the PC via VEGACONNECT	34
7.2	Parameter adjustment with PACTware	35
7.3	Parameter adjustment with AMS™ and PDM	36
7.4	Saving the parameter adjustment data	36
8	Maintenance and fault rectification	
8.1	Maintenance	37
8.2	Rectify faults	37
8.3	Exchanging the electronics module	38

8.4	Software update	38
8.5	Instrument repair	39
9	Dismounting	
9.1	Dismounting steps.....	41
9.2	Disposal	41
10	Supplement	
10.1	Technical data	42
10.2	Dimensions	47

Supplementary documentation



Information:

Supplementary documents appropriate to the ordered version come with the delivery. You can find them listed in chapter "*Product description*".

Instructions manuals for accessories and replacement parts



Tip:

To ensure reliable setup and operation of your VEGASON 61, we offer accessories and replacement parts. The corresponding documentations are:

- 27835 - Display and adjustment module PLICSCOM
- 32628 - Interface adapter VEGACONNECT
- 27720 - External indication VEGADIS 61
- 34296 - Protective cover
- 30176 - Electronics module VEGASON series 60

Editing status: 2013-04-11

1 About this document

1.1 Function

This operating instructions manual provides all the information you need for mounting, connection and setup as well as important instructions for maintenance and fault rectification. Please read this information before putting the instrument into operation and keep this manual accessible in the immediate vicinity of the device.

1.2 Target group

This operating instructions manual is directed to trained specialist personnel. The contents of this manual should be made available to these personnel and put into practice by them.

1.3 Symbolism used



Information, tip, note

This symbol indicates helpful additional information.



Caution: If this warning is ignored, faults or malfunctions can result.

Warning: If this warning is ignored, injury to persons and/or serious damage to the instrument can result.

Danger: If this warning is ignored, serious injury to persons and/or destruction of the instrument can result.



Ex applications

This symbol indicates special instructions for Ex applications.



List

The dot set in front indicates a list with no implied sequence.



Action

This arrow indicates a single action.



Sequence

Numbers set in front indicate successive steps in a procedure.



Battery disposal

This symbol indicates special information about the disposal of batteries and accumulators.

2 For your safety

2.1 Authorised personnel

All operations described in this operating instructions manual must be carried out only by trained specialist personnel authorised by the plant operator.

During work on and with the device the required personal protective equipment must always be worn.

2.2 Appropriate use

VEGASON 61 is a sensor for continuous level measurement.

You can find detailed information on the application range in chapter "*Product description*".

Operational reliability is ensured only if the instrument is properly used according to the specifications in the operating instructions manual as well as possible supplementary instructions.

For safety and warranty reasons, any invasive work on the device beyond that described in the operating instructions manual may be carried out only by personnel authorised by the manufacturer. Arbitrary conversions or modifications are explicitly forbidden.

2.3 Warning about incorrect use

Inappropriate or incorrect use of the instrument can give rise to application-specific hazards, e.g. vessel overfill or damage to system components through incorrect mounting or adjustment.

2.4 General safety instructions

This is a high-tech instrument requiring the strict observance of standard regulations and guidelines. The user must take note of the safety instructions in this operating instructions manual, the country-specific installation standards as well as all prevailing safety regulations and accident prevention rules.

The instrument must only be operated in a technically flawless and reliable condition. The operator is responsible for trouble-free operation of the instrument.

During the entire duration of use, the user is obliged to determine the compliance of the necessary occupational safety measures with the current valid rules and regulations and also take note of new regulations.

2.5 Safety label on the instrument

The safety approval markings and safety tips on the device must be observed.

2.6 CE conformity

This device fulfills the legal requirements of the applicable EC guidelines. By attaching the CE mark, VEGA provides a confirmation of

successful testing. You can find the CE conformity declaration in the download area of "www.vega.com".

2.7 Fulfillment of NAMUR recommendations

NAMUR is the automation technology user association in the process industry in Germany. The published NAMUR recommendations are accepted as the standard in field instrumentation.

The device fulfills the requirements of the following NAMUR recommendations:

- NE 21 – Electromagnetic compatibility of equipment
- NE 43 – Signal level for malfunction information from measuring transducers
- NE 53 – Compatibility of field devices and display/adjustment components

For further information see www.namur.de.

2.8 Safety instructions for Ex areas

Please note the Ex-specific safety information for installation and operation in Ex areas. These safety instructions are part of the operating instructions manual and come with the Ex-approved instruments.

2.9 Environmental instructions

Protection of the environment is one of our most important duties. That is why we have introduced an environment management system with the goal of continuously improving company environmental protection. The environment management system is certified according to DIN EN ISO 14001.

Please help us fulfill this obligation by observing the environmental instructions in this manual:

- Chapter "*Packaging, transport and storage*"
- Chapter "*Disposal*"

3 Product description

3.1 Configuration

Scope of delivery

The scope of delivery encompasses:

- VEGASON 61 ultrasonic sensor
- Documentation
 - this operating instructions manual
 - Safety Manual 28983 "VEGASON 61, 62 - 4 ... 20 mA/HART" (optional)
 - Operating instructions manual 27835 "Display and adjustment module PLICSCOM" (optional)
 - Supplementary instructions manual 31708 "Heating for display and adjustment module PLICSCOM" (optional)
 - Supplementary instructions manual "Plug connector for continuously measuring sensors" (optional)
 - Ex-specific "Safety instructions" (with Ex versions)
 - if necessary, further certificates

Constituent parts

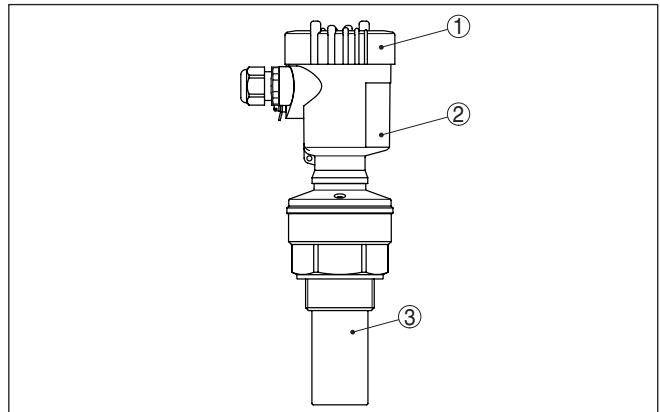

Fig. 1: VEGASON 61 - version with plastic housing

- 1 Housing cover with integrated PLICSCOM (optional)
- 2 Housing with electronics, optionally available with plug connector
- 3 Process fitting with transducer

The VEGASON 61 consists of the components:

- Transducer with integrated temperature sensor
- Housing with electronics, optionally available with plug connector
- Housing cover, optionally available with display and adjustment module PLICSCOM

The components are available in different versions.

Type plate

The nameplate contains the most important data for identification and use of the instrument:

- Instrument version
- Article and serial number device

- Article numbers, documentation
- Technical data: For example approvals, process temperature, process fitting/material, signal output, power supply, protection
- SIL identification (with SIL rating ex works)

With the serial number, you can access the delivery data of the instrument via www.vega.com, "VEGA Tools" and "serial number search". In addition to the type label outside, you can also find the serial number on the inside of the instrument.

3.2 Principle of operation

Application area

VEGASON 61 is an ultrasonic sensor for continuous level measurement. It is suitable for liquids and solids in virtually all industries, particularly in the water and waste water industry.

Functional principle

The transducer of the ultrasonic sensor transmits short ultrasonic pulses to the measured product. These pulses are reflected by product surface and received back by the transducer as echoes. The running time of the ultrasonic pulses from emission to reception is proportional to the distance and hence the level. The determined level is converted into an appropriate output signal and outputted as measured value.

Voltage supply

4 ... 20 mA/HART two-wire electronics for voltage supply and measured value transmission on the same cable.

The supply voltage range can differ depending on the instrument version.

The data for power supply are specified in chapter "Technical data".

The optional background lighting of the display and adjustment module is powered by the sensor. A certain level of operating voltage is required for this. You can find the exact voltage specifications in chapter "Technical data".

The optional heating requires its own operating voltage. You can find details in the supplementary instructions manual "Heating for display and adjustment module".

This function is generally not available for approved instruments.

3.3 Operation

The instrument can be adjusted with the following adjustment media:

- With the display and adjustment module
- with the suitable VEGA DTM in conjunction with an adjustment software according to the FDT/DTM standard, e.g. PACTware and PC
- with manufacturer-specific adjustment programs AMS™ or PDM
- With a HART handheld

3.4 Packaging, transport and storage

Packaging

Your instrument was protected by packaging during transport. Its capacity to handle normal loads during transport is assured by a test based on ISO 4180.

The packaging of standard instruments consists of environment-friendly, recyclable cardboard. For special versions, PE foam or PE foil is also used. Dispose of the packaging material via specialised recycling companies.

Transport

Transport must be carried out under consideration of the notes on the transport packaging. Nonobservance of these instructions can cause damage to the device.

Transport inspection

The delivery must be checked for completeness and possible transit damage immediately at receipt. Ascertained transit damage or concealed defects must be appropriately dealt with.

Storage

Up to the time of installation, the packages must be left closed and stored according to the orientation and storage markings on the outside.

Unless otherwise indicated, the packages must be stored only under the following conditions:

- Not in the open
- Dry and dust free
- Not exposed to corrosive media
- Protected against solar radiation
- Avoiding mechanical shock and vibration

Storage and transport temperature

- Storage and transport temperature see chapter "*Supplement - Technical data - Ambient conditions*"
- Relative humidity 20 ... 85 %

4 Mounting

4.1 General instructions

Suitability for the process conditions

Make sure that all parts of the instrument coming in direct contact with the process, especially the sensor element, process seal and process fitting, are suitable for the existing process conditions, such as process pressure, process temperature as well as the chemical properties of the medium.

You can find the specifications in chapter "*Technical data*" and on the nameplate.

Installation position

Select an installation position you can easily reach for mounting and connecting as well as later retrofitting of a display and adjustment module. The housing can be rotated by 330° without the use of any tools. You can also install the display and adjustment module in four different positions (each displaced by 90°).

Moisture

Use the recommended cables (see chapter "*Connecting to power supply*") and tighten the cable gland.

You can give your instrument additional protection against moisture penetration by leading the connection cable downward in front of the cable entry. Rain and condensation water can thus drain off. This applies mainly to outdoor mounting as well as installation in areas where high humidity is expected (e.g. through cleaning processes) or on cooled or heated vessels.

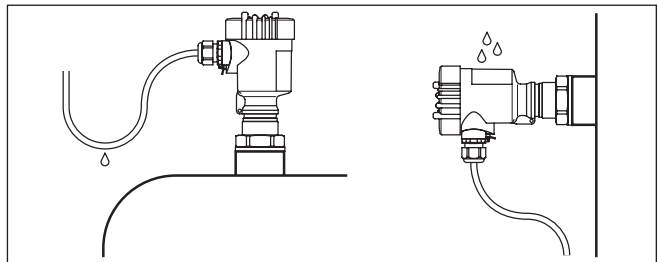

Fig. 2: Measures against moisture penetration

Measuring range

The reference plane for the measuring range is the lower edge of the transducer.

Make sure that a minimum distance from the reference plane - the so-called dead band, in which measurement is not possible - is maintained. The exact value of the dead band is stated in chapter "*Technical data*".

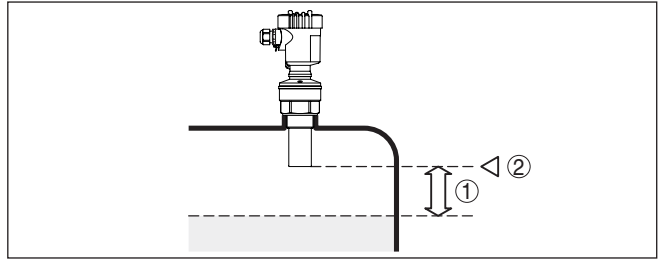

Fig. 3: Minimum distance to the max. level

- 1 Dead band
- 2 Reference plane



Information:

If the medium reaches the transducer, buildup can form on it and cause faulty measurements later on.

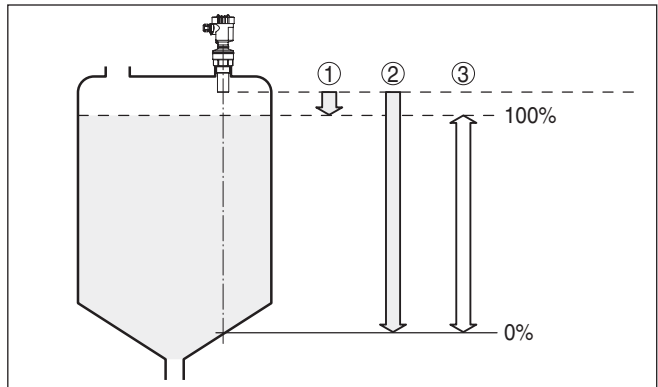

Fig. 4: Measuring range (operating range) and max. measuring distance

- 1 full
- 2 empty (max. measuring distance)
- 3 Measuring range

Pressure/Vacuum

Gauge pressure in the vessel does not influence VEGASON 61. Low pressure or vacuum does, however, damp the ultrasonic pulses. This influences the measuring result, particularly if the level is very low. With pressures under -0.2 bar (-20 kPa) you should use a different measuring principle, e.g. radar or guided microwave.

4.2 Mounting instructions

Screwing in

Screw VEGASON 61 into the mounting socket with an appropriate spanner applied to the hexagon of the process fitting. Max. torque see chapter "Technical data".



Warning:

The housing must not be used to screw the instrument in! Applying tightening force can damage internal parts of the housing.

Installation position

When mounting the sensor, keep a distance of at least 200 mm (7.874 in) to the vessel wall. If the sensor is installed in the center of dished or round vessel tops, multiple echoes can arise. These can, however, be suppressed by an appropriate adjustment (see chapter "Setup").

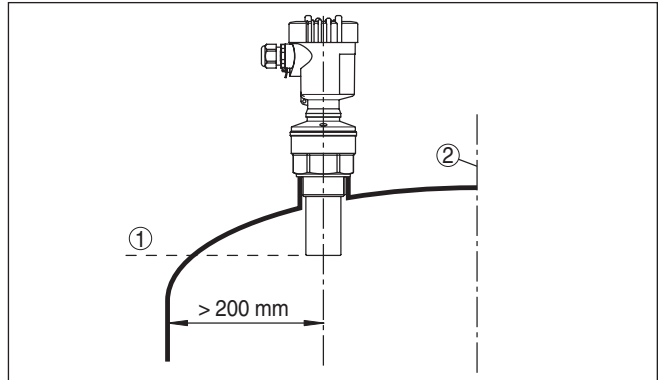

Fig. 5: Mounting on round vessel tops

- 1 Reference plane
- 2 Vessel center or symmetry axis

If you cannot keep this distance you should carry out a false echo storage before setup. This applies mainly if buildup on the vessel wall is expected. In this case, we recommend repeating a false echo storage later with existing buildup.

In vessels with conical bottom it can be advantageous to mount the sensor in the center of the vessel, as measurement is then possible down to the lowest point of the vessel bottom.

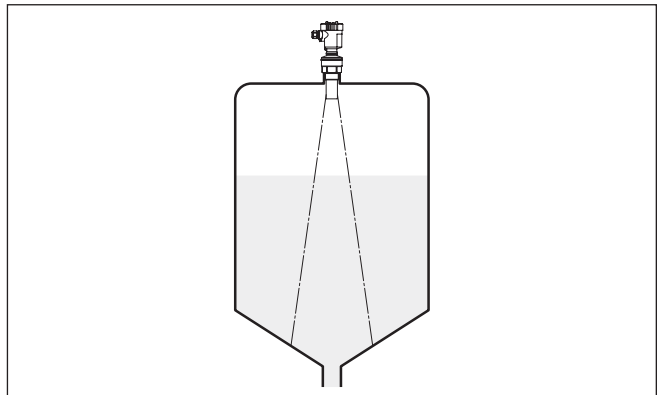

Fig. 6: Vessel with conical bottom

Socket

Socket pieces should be dimensioned so that the lower end of the transducer protrudes at least 10 mm (0.394 in) out of the socket.

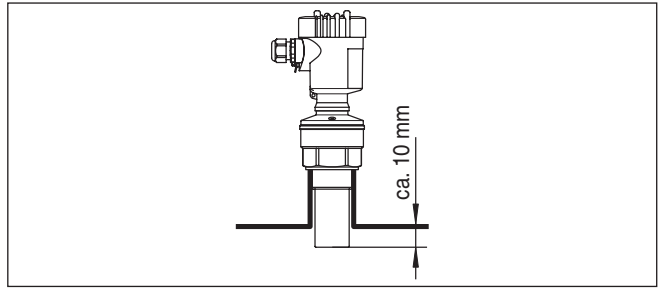

Fig. 7: Recommended socket mounting

If the reflective properties of the medium are good, you can mount VEGASON 61 on sockets which are higher than the length of the transducer. You will find recommended values for socket heights in the following illustration. The socket end should be smooth and burr-free, if possible also rounded. Carry out a false echo storage.

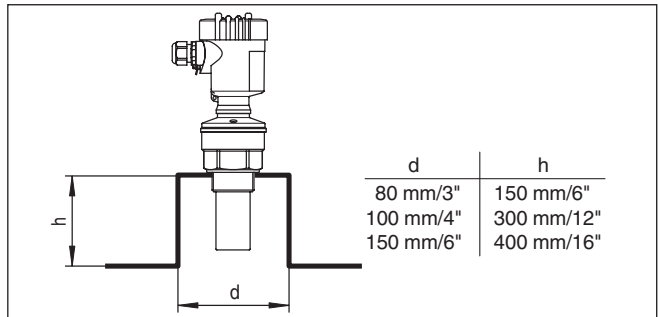

Fig. 8: Deviating socket dimensions

Sensor orientation

Align the sensor in liquids as vertical as possible to the product surface to achieve an optimum measurement result.

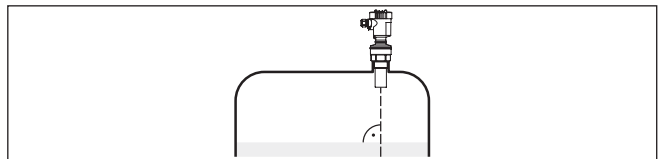

Fig. 9: Alignment in liquids

To reduce the min. distance to the medium, you can also mount VEGASON 61 with a beam deflector. By doing this, it is possible to fill the vessel nearly to maximum. Such an arrangement is suitable primarily for open vessels such as e.g. overflow basins.

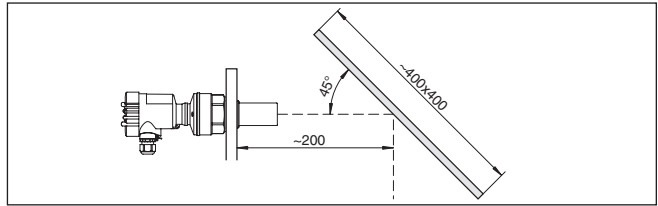

Fig. 10: Beam deflector

Vessel installations

The ultrasonic sensor should be installed at a location where no installations cross the ultrasonic beam.

Vessel installations such as for example, ladders, limit switches, heating spirals, struts etc. can cause false echoes that interfere with the useful echo. Make sure when planning your measuring site that the ultrasonic signals have a "clear view" to the measured product.

In case of existing vessel installations, a false echo storage should be carried out during setup.

If large vessel installations such as struts or supports cause false echoes, these can be attenuated through supplementary measures. Small, inclined sheet metal or plastic baffles above the installations scatter the ultrasonic signals and avoid direct false echoes.

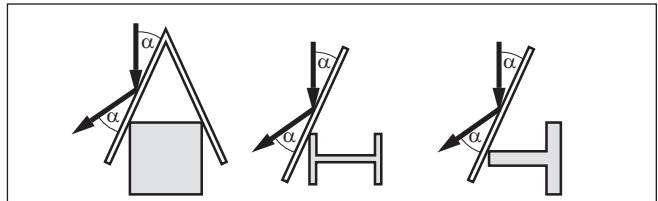

Fig. 11: Cover smooth profiles with deflectors

Agitators

If there are agitators in the vessel, a false signal memory should be carried out with the agitators in motion. This ensures that the interfering reflections from the agitators are saved with the blades in different positions.

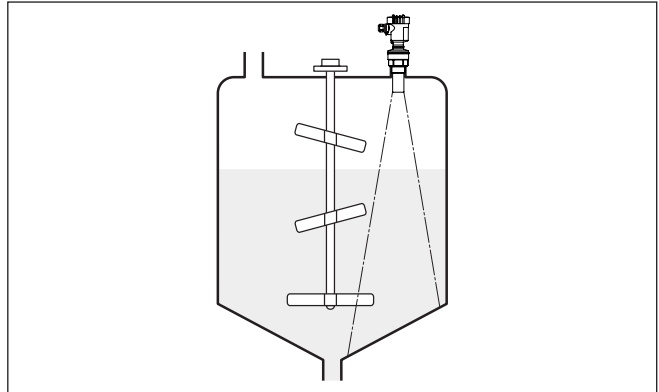

Fig. 12: Agitators

Inflowing medium

Do not mount the instruments in or above the filling stream. Make sure that you detect the product surface, not the inflowing product.

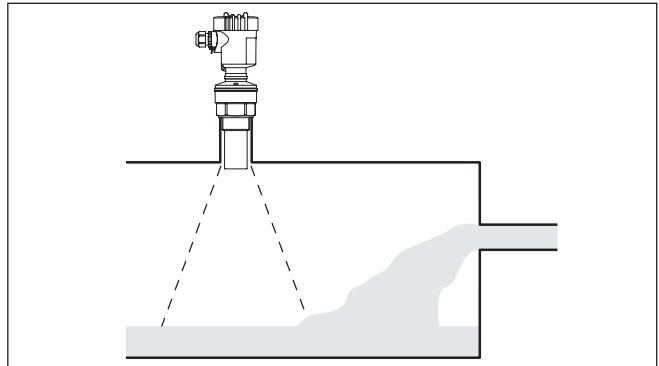

Fig. 13: Inflowing liquid

Foam

Through the action of filling, stirring and other processes in the vessel, dense foams which considerably damp the emitted signals may form on the product surface.

If foams are causing measurement errors, the sensor should be used in a standpipe or, alternatively, the more suitable guided radar sensors (TDR) should be used.

Guided wave radar is unaffected by foam generation and is particularly suitable for such applications.

Air turbulences

If there are strong air currents in the vessel, e.g. due to strong winds in outdoor installations or air turbulence, e.g. by cyclone extraction you should mount VEGASON 61 in a standpipe or use a different measuring principle, e.g. radar or guided radar (TDR).

Standpipe measurement

By using a standpipe (surge or bypass tube), the influence of vessel installations, foam generation and turbulence is excluded.

Standpipes must extend all the way down to the requested min. level, as measurement is only possible within the tube.

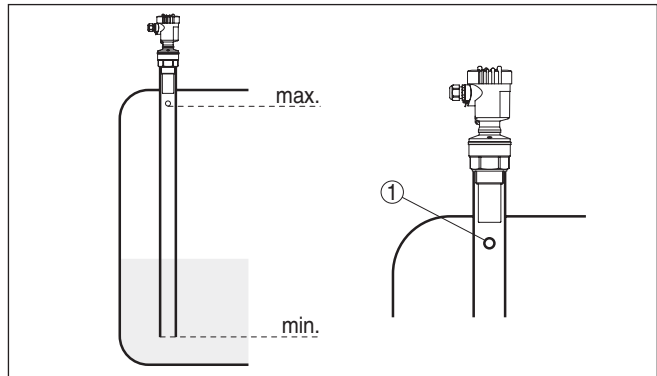

Fig. 14: Standpipe in the tank

1 Vent hole: $\varnothing 5 \dots 10 \text{ mm}$ (0.197 ... 0.394 in)

VEGASON 61 can be used from tube diameters of 40 mm (1.575 in).

Avoid large gaps and thick welding joints when connecting the tubes. Generally carry out a false echo storage.

Measurement in a standpipe is not recommended for extremely adhesive products.

5 Connecting to power supply

5.1 Preparing the connection

Safety instructions

Always keep in mind the following safety instructions:

- Connect only in the complete absence of line voltage
- If overvoltage surges are expected, overvoltage arresters should be installed



Tip:

We recommend using VEGA overvoltage arresters B63-48 and ÜSB 62-36G.X.



In hazardous areas you must take note of the respective regulations, conformity and type approval certificates of the sensors and power supply units.

Voltage supply

Power supply and current signal are carried on the same two-wire cable. The voltage supply range can differ depending on the instrument version.

The data for power supply are specified in chapter "*Technical data*".

Provide a reliable separation between the supply circuit and the mains circuits according to DIN EN 61140 VDE 0140-1. The VEGA power supply units VEGATRENN 149A Ex, VEGASTAB 690 as well as all VEGAMETs and VEGASCANs meet this requirement.

Keep in mind the following additional factors that influence the operating voltage:

- Output voltage of the power supply unit can be lower under nominal load (with a sensor current of 20.5 mA or 22 mA in case of fault message)
- Influence of additional instruments in the circuit (see load values in chapter "*Technical data*")

Connection cable

The instrument is connected with standard two-wire cable without screen. If electromagnetic interference is expected which is above the test values of EN 61326 for industrial areas, screened cable should be used.

Use cable with round cross-section. A cable outer diameter of 5 ... 9 mm (0.2 ... 0.35 in) ensures the seal effect of the cable gland. If you are using cable with a different diameter or cross-section, exchange the seal or use a suitable cable gland.

We generally recommend the use of screened cable for HART multi-drop mode.

Cable gland ½ NPT

On the instrument with cable entry ½ NPT and plastic housing there is a metallic ½" threaded insert moulded into the plastic housing.



Caution:

No grease should be used when screwing the NPT cable gland or steel tube into the threaded insert. Standard grease can contain additives that corrode the connection between threaded insert and

Cable screening and grounding

housing. This would influence the stability of the connection and the tightness of the housing.

If screened cable is necessary, connect the cable screen on both ends to ground potential. In the sensor, the screen must be connected directly to the internal ground terminal. The ground terminal on the outside of the housing must be connected to the potential equalisation (low impedance).

If potential equalisation currents are expected, the connection on the processing side must be made via a ceramic capacitor (e. g. 1 nF, 1500 V). The low-frequency potential equalisation currents are thus suppressed, but the protective effect against high frequency interference signals remains.



Warning:

Considerable potential differences exist inside galvanic plants as well as vessels with cathodic corrosion protection. Very large equalisation currents can flow through the cable screen when the screen is grounded on both ends. To avoid this, the cable screen must be connected to ground potential only on one end (inside the switching cabinet) in such applications. The cable screen must **not** be connected to the internal ground terminal in the sensor and the outer ground terminal on the housing **not** to potential equalisation!



Information:

The metallic parts of the instrument (transmitter, process fitting, etc.) are conductively connected with the inner and outer ground terminal on the housing. This connection exists either as a direct metallic contact or via the shielding of the special connection cable on instruments with external electronics. You can find specifications on the potential connections within the instrument in chapter "*Technical data*".



Take note of the corresponding installation regulations for Ex applications. In particular, make sure that no potential equalisation currents flow over the cable screen. In case of grounding on both sides this can be achieved by the use of a capacitor or a separate potential equalisation.

5.2 Connection procedure

Proceed as follows:

1. Unscrew the housing cover
2. If a display and adjustment module is installed, remove it by turning it to the left.
3. Loosen compression nut of the cable entry
4. Remove approx. 10 cm (4 in) of the cable mantle, strip approx. 1 cm (0.4 in) of insulation from the ends of the individual wires
5. Insert the cable into the sensor through the cable entry
6. Lift the opening levers of the terminals with a screwdriver (see following illustration)
7. Insert the wire ends into the open terminals according to the wiring plan

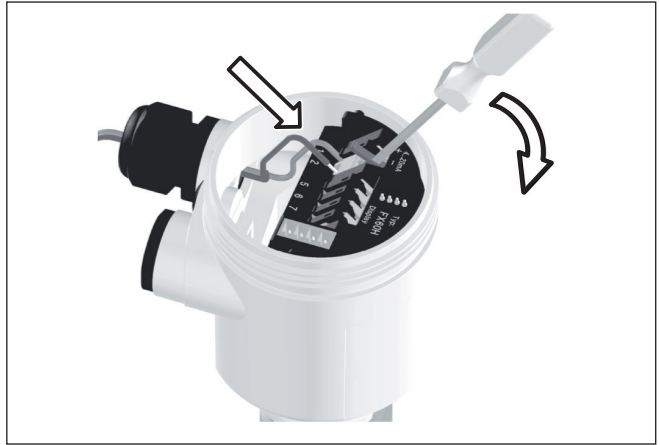

Fig. 15: Connection steps 6 and 7

8. Press down the opening levers of the terminals, you will hear the terminal spring closing
 9. Check the hold of the wires in the terminals by lightly pulling on them
 10. Connect the screen to the internal ground terminal, connect the outer ground terminal to potential equalisation
 11. Tighten the compression nut of the cable entry. The seal ring must completely encircle the cable
 12. Screw the housing cover back on
- The electrical connection is hence finished.

5.3 Wiring plan, single chamber housing



The following illustrations apply to the non-Ex as well as to the Ex-ia version.

Housing overview

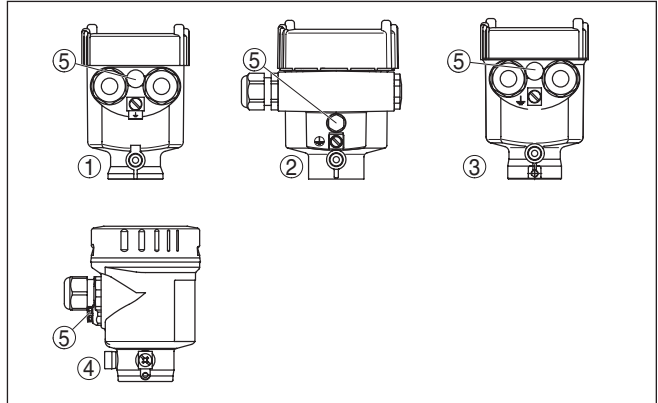

Fig. 16: Material versions, single chamber housing

- 1 Plastic
- 2 Aluminium
- 3 Stainless steel, investment casting
- 4 Stainless steel, electro-polished
- 5 Filter element for air pressure compensation of all material versions. Blind plug with version IP 66/IP 68, 1 bar for Aluminium and stainless steel

Electronics and connection compartment

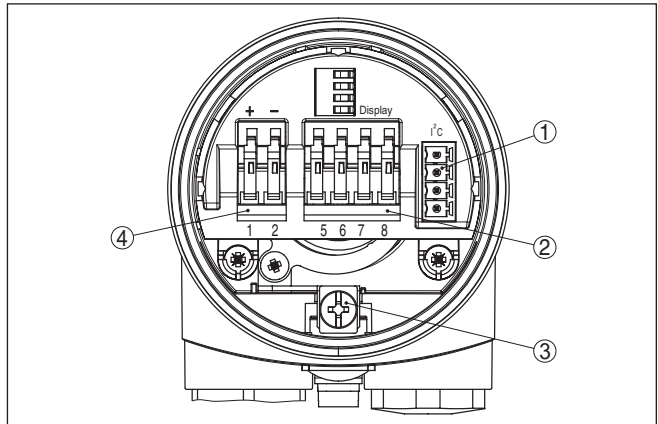

Fig. 17: Electronics and connection compartment, single chamber housing

- 1 Plug connector for VEGACONNECT (I²C interface)
- 2 Spring-loaded terminals for connection of the external indication VEGADIS 61
- 3 Ground terminal for connection of the cable screen
- 4 Spring-loaded terminals for voltage supply

Wiring plan

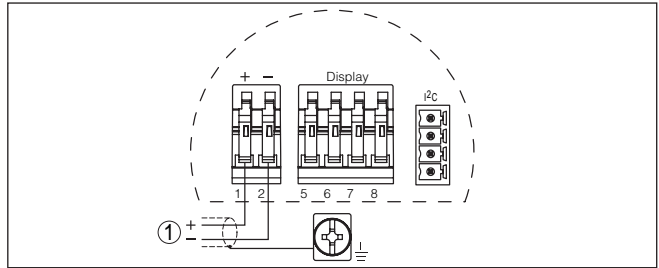

Fig. 18: Wiring plan, single chamber housing

1 Voltage supply, signal output

5.4 Wiring plan, double chamber housing



The following illustrations apply to the non-Ex as well as to the Ex-ia version.

Housing overview

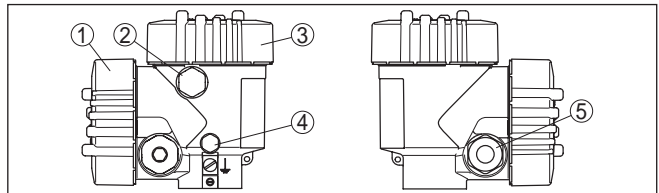

Fig. 19: Double chamber housing

- 1 Housing cover, connection compartment
- 2 Blind plug or plug M12 x 1 for VEGADIS 61 (optional)
- 3 Housing cover, electronics compartment
- 4 Filter element for air pressure compensation
- 5 Cable gland

Electronics compartment

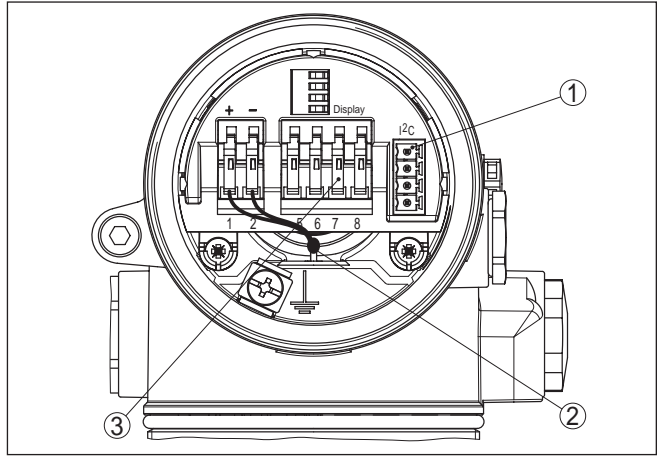

Fig. 20: Electronics compartment, double chamber housing

- 1 Plug connector for VEGACONNECT (I²C interface)
- 2 Internal connection cable to the connection compartment
- 3 Terminals for VEGADIS 61

Connection compartment

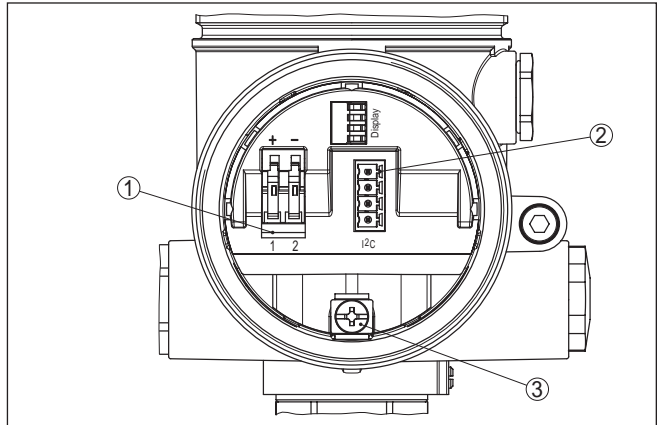

Fig. 21: Connection compartment, double chamber housing

- 1 Spring-loaded terminals for voltage supply
- 2 Plug connector for VEGACONNECT (I²C interface)
- 3 Ground terminal for connection of the cable screen

Wiring plan

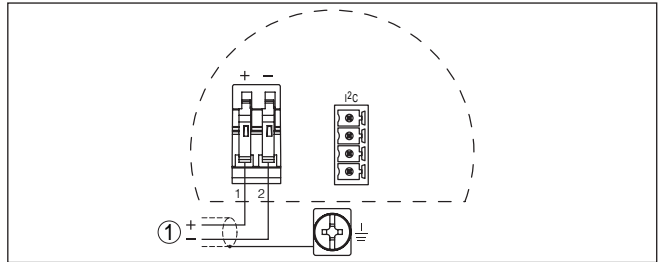

Fig. 22: Wiring plan, double chamber housing

1 Voltage supply, signal output

Wire assignment, connection cable

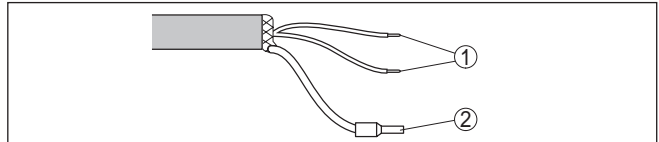

Fig. 23: Wire assignment, connection cable

1 brown (+) and blue (-) to power supply or to the processing system
 2 Shielding

5.6 Switch-on phase

Switch-on phase

After connecting VEGASON 61 to power supply or after a voltage recurrence, the instrument carries out a self-check for approx. 30 seconds:

- Internal check of the electronics
- Indication of the instrument type, the firmware as well as the sensor TAGs (sensor designation)
- Output signal jumps briefly (approx. 10 seconds) to the set fault current

Then the corresponding current is outputted to the cable (the value corresponds to the actual level as well as the settings already carried out, e.g. factory setting).

6 Set up with the display and adjustment module PLICSCOM

Function/Configuration

6.1 Short description

The display and adjustment module is used for measured value display, adjustment and diagnosis. It can be mounted in the following housing versions and instruments:

- All sensors of the plics® instrument family, in the single as well as in the double chamber housing (optionally in the electronics or connection compartment)
- External display and adjustment unit VEGADIS 61

With hardware version ...- 01 or higher of PLICSCOM or ...- 02, ...-04 or higher of the respective sensor, an integrated backlight can be switched on via the adjustment menu. The hardware version is stated on the type label of the PLICSCOM or the sensor electronics.



Note:

You can find detailed information on the adjustment in the operating instructions manual "*Display and adjustment module*".

Mount/Dismount display and adjustment module

6.2 Insert display and adjustment module

The display and adjustment module can be inserted into the sensor and removed again at any time. It is not necessary to interrupt the power supply.

Proceed as follows:

1. Unscrew the housing cover
2. Place the display and adjustment module in the desired position on the electronics (you can choose any one of four different positions - each displaced by 90°)
3. Press the display and adjustment module onto the electronics and turn it to the right until it snaps in.
4. Screw housing cover with inspection window tightly back on

Removal is carried out in reverse order.

The display and adjustment module is powered by the sensor, an additional connection is not necessary.



Fig. 24: Insert display and adjustment module



Note:

If you intend to retrofit the instrument with a display and adjustment module for continuous measured value indication, a higher cover with an inspection glass is required.

6.3 Adjustment system

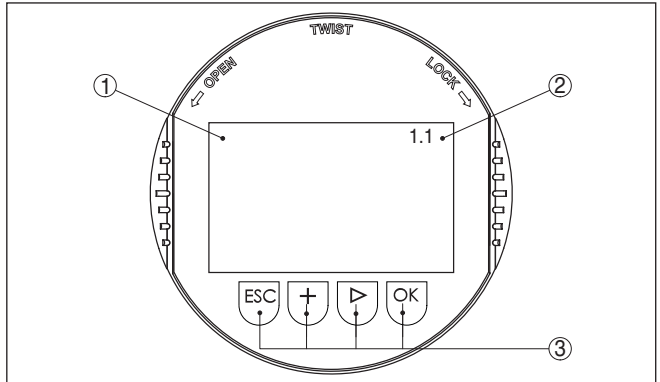

Fig. 25: Display and adjustment elements

- 1 LC display
- 2 Indication of the menu item number
- 3 Adjustment keys

Key functions

- **[OK]** key:
 - Move to the menu overview
 - Confirm selected menu
 - Edit parameter

- Save value
- [->] key to select:
 - Menu change
 - Select list entry
 - Select editing position
- [+] key:
 - Change value of the parameter
- [ESC] key:
 - interrupt input
 - Jump to next higher menu

Adjustment system

The sensor is adjusted via the four keys of the display and adjustment module. The LC display indicates the individual menu items. The functions of the individual keys are shown in the above illustration. Approx. 10 minutes after the last pressing of a key, an automatic reset to measured value indication is triggered. Any values not confirmed with **[OK]** will not be saved.

Address setting HART multidrop

6.4 Setup steps

In HART-Multidrop mode (several sensors on one input) the address must be set before continuing with the parameter adjustment. You will find a detailed description in the operating instructions manual "*Display and adjustment module*" or in the online help of PACTware or DTM.

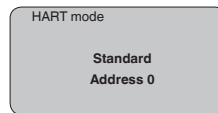

Parameter adjustment

As VEGASON 61 is a distance measuring instrument, the distance from the sensor to the product surface is measured. To have the real product level displayed, an allocation of the measured distance to the percentage height must be made. To carry out this adjustment, the distance is entered with full and empty vessel. If these values are not known, an adjustment with the distance values, e.g. 10 % and 90 % is also possible. Starting point for these distance specifications is always the lower side of the flange, with all other versions the lower side of the transducer.

The actual level is then calculated on the basis of these entered values. At the same time, the operating range of the sensor is limited from maximum range to the requested range.

The real product level during this adjustment is not important, because the min./max. adjustment is always carried out without changing the product level. These settings can be made ahead of time without the instrument having to be installed.

In the main menu item "*Basic adjustment*", the individual submenu items should be selected one after the other and provided with the correct parameter values.

Start your parameter adjustment with the following menu items of the basic adjustment:

Carry out min. adjustment Proceed as follows:

1. Move from the measured value display to the main menu by pushing **[OK]**.

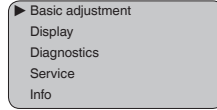

2. Select the menu item "Basic adjustment" with **[->]** and confirm with **[OK]**. Now the menu item "Min. adjustment" is displayed.

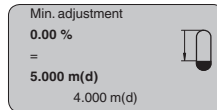

3. Prepare the % value for editing with **[OK]** and set the cursor to the requested position with **[->]**. Set the requested percentage value with **[+]** and save with **[OK]**. The cursor jumps now to the distance value.
4. Enter the suitable distance value in m for the empty vessel (e.g. distance from the sensor to the vessel bottom) corresponding to the percentage value.
5. Save the settings with **[OK]** and move to "Max. adjustment" with **[->]**.

Carry out max. adjustment

Proceed as follows:

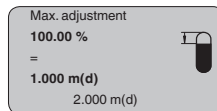

1. Prepare the % value for editing with **[OK]** and set the cursor to the requested position with **[->]**. Set the requested percentage value with **[+]** and save with **[OK]**. The cursor jumps now to the distance value.
2. Enter the appropriate distance value in m (corresponding to the percentage value) for the full vessel. Keep in mind that the max. level must lie below the dead band.
3. Save the settings with **[OK]** and move to "Medium selection" with **[->]**.

Medium selection

Each product has different reflective properties. In addition, there are various interfering factors which have to be taken into account: agitated product surfaces and foam generation (with liquids); dust generation, material cones and echoes from the vessel wall (with solids). To adapt the sensor to these different conditions, you should first select "Liquid" or "Solid".

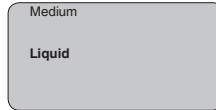

With solids, you can also choose between "Powder/Dust", "Granular/Pellets" or "Ballast/Pebbles".

Through this additional selection, the sensor is adapted perfectly to the product and measurement reliability, particularly in products with poor reflective properties, is considerably increased.

Enter the requested parameters via the appropriate keys, save your settings and jump to the next menu item with the [→] key.

Vessel form

Apart from the medium, the vessel shape can also influence the measurement. To adapt the sensor to these measuring conditions, this menu item offers different options depending on whether liquid or bulk solid is selected. With "Liquids" these are "Storage tank", "Stilling tube", "Open vessel" or "Stirred vessel", with "Solid", "Silo" or "Bunker".

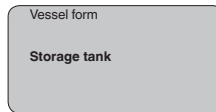

Enter the requested parameters via the appropriate keys, save your settings and jump to the next menu item with the [→] key.

Damping

To suppress fluctuations in the measured value display, e. g. caused by an agitated product surface, a damping can be set. This time can be between 0 and 999 seconds. Keep in mind that the reaction time of the entire measurement will then be longer and the sensor will react to measured value changes with a delay. In general, a period of a few seconds is sufficient to smooth the measured value display.

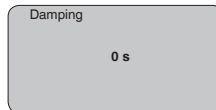

Enter the requested parameters via the appropriate keys, save your settings and jump to the next menu item with the [→] key.

Linearization curve

A linearisation is necessary for all vessels in which the vessel volume does not increase linearly with the level - e.g. in a horizontal cylindrical or spherical tank - and the indication or output of the volume is required. Corresponding linearisation curves are preprogrammed for these vessels. They represent the correlation between the level percentage and vessel volume. By activating the appropriate curve, the volume percentage of the vessel is displayed correctly. If the volume should not be displayed in percent but e.g. in l or kg, a scaling can be also set in the menu item "Display".

Linearization curve

Enter the requested parameters via the appropriate keys, save your settings and jump to the next menu item with the **[->]** key.

Sensor-TAG

In this menu item you can enter an unambiguous designation for the sensor, e.g. the measurement loop name or the tank or product designation. In digital systems and in the documentation of larger plants, a singular designation should be entered for exact identification of individual measuring points.

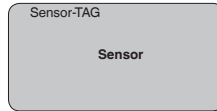

With this menu item, the Basic adjustment is finished and you can now jump to the main menu with the **[ESC]** key.

False signal suppression

High sockets or vessel installations, such as e. g. struts or agitators as well as buildup and weld joints on the vessel walls, cause interfering reflections which can impair the measurement. A false echo detector detects and marks these false echoes, so that they are no longer taken into account for the level measurement. A false echo memory should be created with low level so that all potential interfering reflections can be detected.

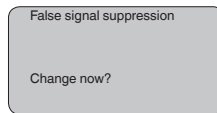

Proceed as follows:

1. Move the measured value display to the main menu by pushing **[OK]**.
2. Select the menu item "Service" with **[->]** and confirm with **[OK]**. Now the menu item "False signal suppression" is displayed.
3. Confirm "False signal suppression - Change now" with **[OK]** and select in the below menu "Create new". Enter the actual distance from the sensor to the product surface. All false signals in this area are detected by the sensor and saved after confirming with **[OK]**.



Note:

Check the distance to the product surface, because if an incorrect (too large) value is entered, the existing level will be saved as a false echo. The filling level would then no longer be detectable in this area.

Extended setting/Quick level change

The menu item "Extended setting" offers the possibility to optimise VEGASON 61 for applications in which the level changes very quickly. To do this, select the function "Quick level change > 1 m/min".

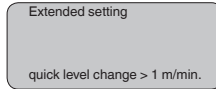
**Note:**

Since with the function "Quick level change > 1 m/min." the generation of an average value of the signal processing is considerably reduced, false reflections by agitators or vessel installations can cause measured value fluctuations. A false echo memory is thus recommended.

Copy sensor data

This function enables reading out parameter adjustment data as well as writing parameter adjustment data into the sensor via the display and adjustment module. A description of the function is available in the operating instructions manual "Display and adjustment module".

The following data are read out or written with this function:

- Measured value presentation
- Adjustment
- Medium
- Vessel form
- Damping
- Linearization curve
- Sensor-TAG
- Displayed value
- Display unit
- Scaling
- Current output
- Unit of measurement
- Language

The following safety-relevant data are **not** read out or written:

- HART mode
- PIN

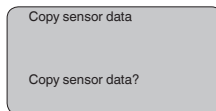
**Reset****Basic adjustment**

If the function "Reset" is carried out, the sensor resets the values of the following menu items to the reset values (see chart):¹⁾

Function	Reset value
Sensor address	126
Max. adjustment	0 m(d)
Min. adjustment	Meas. range end in m(d) ²⁾
Medium	Liquid

¹⁾ Sensor-specific basic adjustment.

²⁾ Depending on the sensor type, see chapter "Technical data".

Function	Reset value
Vessel form	not known
Damping	0 s
Linearization	Linear
Sensor-TAG	Sensor
Displayed value	Distance
Current output - characteristics	4 ... 20 mA
Current output - max. current	20 mA
Current output - min. current	4 mA
Current output - failure	< 3.6 mA
Unit of measurement	m(d)

The values of the following menu items are *not* reset to the reset values (see chart) with "Reset":

Function	Reset value
Backlight	No reset
Language	No reset
HART mode	No reset

Default setting

Like basic adjustment, but in addition, special parameters are reset to default values.³⁾

Peak value

The min. and max. distance and temperature values are reset to the actual value.

Optional settings

Additional adjustment and diagnosis options such as e.g. scaling, simulation or trend curve presentation are shown in the following menu schematic. You will find a detailed description of these menu items in the operating instructions manual "*Display and adjustment module*".

6.5 Menu plan ultrasonic sensor



Information:

Depending on the version and application, the highlighted menu windows may not always be available.

³⁾ Special parameters are parameters which are set customer-specifically on the service level with the adjustment software PACTware.

Basic adjustment

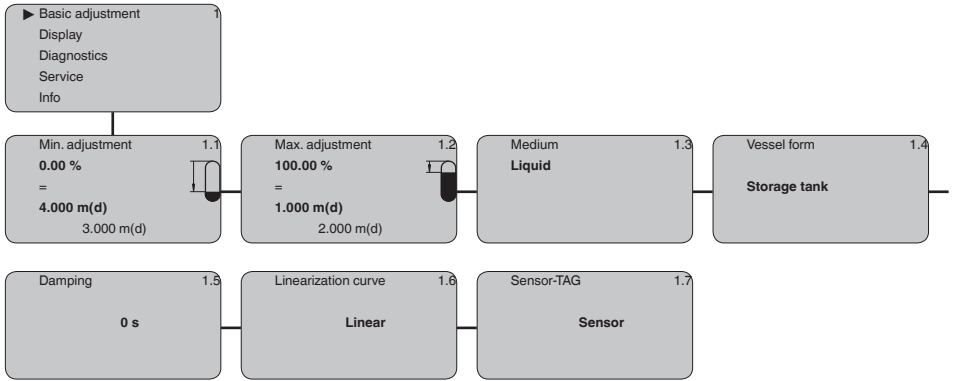

Display

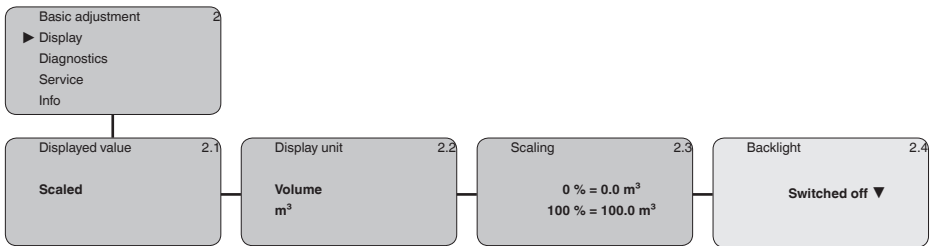

Diagnostics

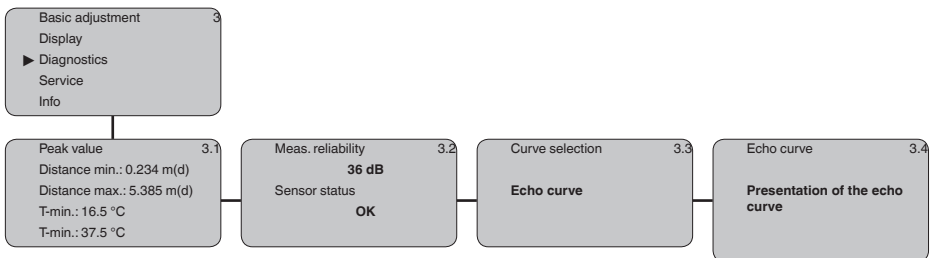

Service

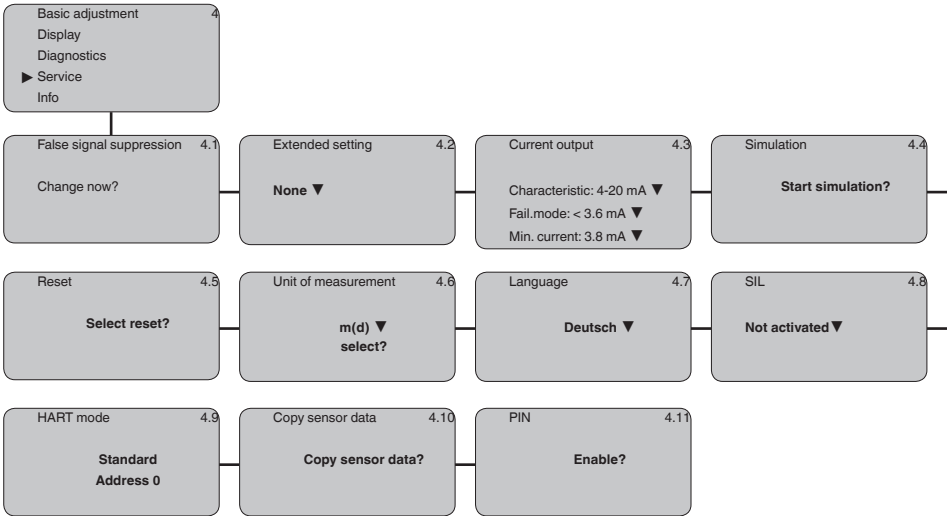

Info

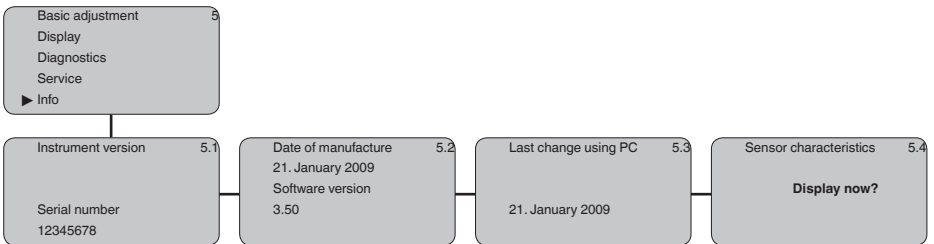

6.10 Saving the parameter adjustment data

We recommended noting the adjusted data, e.g. in this operating instructions manual, and archiving them afterwards. They are thus available for multiple use or service purposes.

If VEGASON 61 is equipped with a display and adjustment module, the most important data can be read out of the sensor into the display and adjustment module. The procedure is described in the operating instructions manual "Display and adjustment module" in the menu item "Copy sensor data". The data remain there permanently even if the sensor power supply fails.

If it is necessary to exchange the sensor, the display and adjustment module is inserted into the replacement instrument and the data are written into the sensor under the menu item "Copy sensor data".

7 Set up with PACTware and other adjustment programs

7.1 Connect the PC via VEGACONNECT

VEGACONNECT directly on the sensor

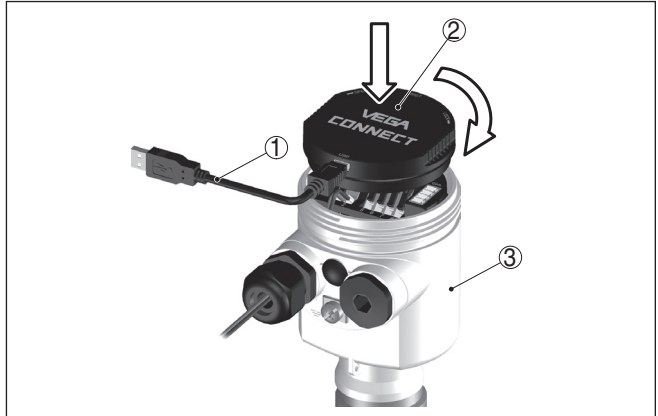

Fig. 26: Connection of the PC via VEGACONNECT directly to the sensor

- 1 USB cable to the PC
- 2 VEGACONNECT
- 3 Sensor

VEGACONNECT externally

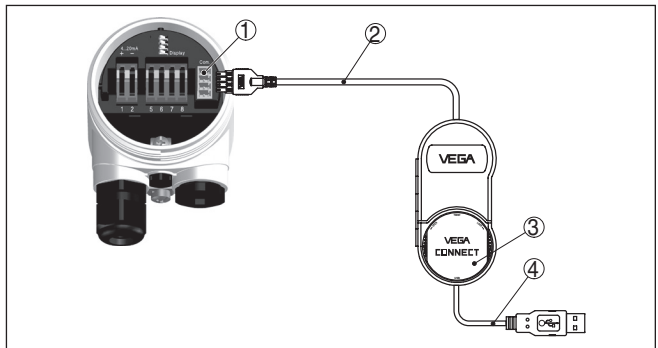

Fig. 27: Connection via VEGACONNECT externally

- 1 I²C bus (com.) interface on the sensor
- 2 I²C connection cable of VEGACONNECT
- 3 VEGACONNECT
- 4 USB cable to the PC

Necessary components:

- VEGASON 61
- PC with PACTware and suitable VEGA DTM
- VEGACONNECT
- Power supply unit or processing system

VEGACONNECT via HART

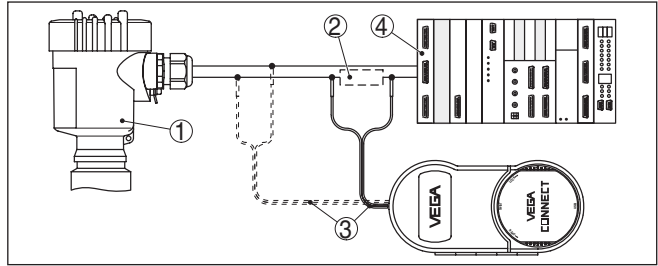

Fig. 28: Connecting the PC via HART to the signal cable

- 1 VEGASON 61
- 2 HART resistance 250 Ω (optional depending on processing)
- 3 Connection cable with 2 mm pins and terminals
- 4 Processing system/PLC/Voltage supply

Necessary components:

- VEGASON 61
- PC with PACTware and suitable VEGA DTM
- VEGACONNECT
- HART resistance approx. 250 Ω
- Power supply unit or processing system



Note:

With power supply units with integrated HART resistance (internal resistance approx. 250 Ω), an additional external resistance is not necessary. This applies, e. g. to the VEGA instruments VEGATRENN 149A, VEGADIS 371, VEGAMET 381. Common Ex separators are also usually equipped with a sufficient current limitation resistance. In such cases, VEGACONNECT 4 can be connected parallel to the 4 ... 20 mA cable.

7.2 Parameter adjustment with PACTware

Further setup steps are described in the operating instructions manual "DTM Collection/PACTware" attached to each CD and which can also be downloaded from our homepage. A detailed description is available in the online help of PACTware and the VEGA DTMs.



Note:

Keep in mind that for setup of VEGASON 61, DTM-Collection in the actual version must be used.

All currently available VEGA DTMs are included as a DTM Collection on a CD. They can be purchased for a token fee from the responsible VEGA agency. In addition, the actual PACTware version is also available on this CD.

In addition, this DTM Collection incl. the basic version of PACTware can be downloaded free of charge from the Internet. Move via www.vega.com and "Downloads" to "Software".

7.3 Parameter adjustment with AMS™ and PDM

For VEGA sensors, instrument descriptions for the adjustment programs AMS™ and PDM are available as DD or EDD. The instrument descriptions are already implemented in the current versions of AMS™ and PDM.

For older versions of AMS™ and PDM, a free-of-charge download is available via Internet. Move via www.vega.com and "Downloads" to "Software".

7.4 Saving the parameter adjustment data

It is recommended to document or save the parameter adjustment data. That way they are available for multiple use or service purposes. The VEGA DTM Collection and PACTware in the licensed, professional version provide suitable tools for systematic project documentation and storage.

8 Maintenance and fault rectification

8.1 Maintenance

If the instrument is used properly, no special maintenance is required in normal operation.

8.2 Rectify faults

Reaction when malfunctions occur

The operator of the system is responsible for taking suitable measures to rectify faults.

Failure reasons

VEGASON 61 offers maximum reliability. Nevertheless, faults can occur during operation. These may be caused by the following, e.g.:

- Sensor
- Process
- Voltage supply
- Signal processing

Fault rectification

The first measures to be taken are to check the output signals as well as to evaluate the error messages via the display and adjustment module. The procedure is described below. Further comprehensive diagnostics can be carried out on a PC with the software PACTware and the suitable DTM. In many cases, the causes can be determined and the faults rectified this way.

24 hour service hotline

Should these measures not be successful, please call in urgent cases the VEGA service hotline under the phone no. **+49 1805 858550**.

The hotline is available to you 7 days a week round-the-clock. Since we offer this service world-wide, the support is only available in the English language. The service is free of charge, only the standard telephone costs will be charged.

Check the 4 ... 20 mA signal

Connect a handmultimeter in the suitable measuring range according to the wiring plan. The following table describes possible errors in the current signal and helps to remove them:

Error	Cause	Rectification
4 ... 20 mA signal not stable	Level fluctuations	Set damping via the display and adjustment module
4 ... 20 mA signal missing	Electrical connection faulty	Check connection according to chapter "Connection steps" and if necessary, correct according to chapter "Wiring plan"
	Voltage supply missing	Check cables for breaks; repair if necessary
	Operating voltage too low or load resistance too high	Check, adapt if necessary

Error	Cause	Rectification
Current signal greater than 22 mA or less than 3.6 mA	Electronics module in the sensor defective	Exchange the instrument or send it in for repair



In Ex applications, the regulations for the wiring of intrinsically safe circuits must be observed.

Error messages via the display and adjustment module

Error code	Cause	Rectification
E013	no measured value available	<ul style="list-style-type: none"> - Sensor in boot phase - Sensor does not find an echo, e.g. due to faulty installation or wrong parameter adjustment
E017	Adjustment span too small	<ul style="list-style-type: none"> - Carry out a fresh adjustment and increase the distance between min. and max. adjustment
E036	no operable sensor software	<ul style="list-style-type: none"> - Carry out a software update or send instrument for repair
E041	Hardware error, electronics defective	<ul style="list-style-type: none"> - Exchange the instrument or send it in for repair

Reaction after fault rectification

Depending on the reason for the fault and the measures taken, the steps described in chapter "Set up" may have to be carried out again.

8.3 Exchanging the electronics module

If the electronics module is defective, it can be replaced by the user.



In Ex applications only one instrument and one electronics module with respective Ex approval may be used.

If there is no electronics module available on site, one can be ordered from the VEGA agency serving you.

Sensor serial number

The new electronics module must be loaded with the settings of the sensor. These are the options:

- At the factory by VEGA
- Or on site by the user

In both cases, the sensor serial number is necessary. The serial numbers are stated on the type label of the instrument, inside the housing or on the delivery note.



Information:

When loading on site, first of all the order data must be downloaded from the Internet (see operating instructions manual "Electronics module").

Assignment

The electronics modules are adapted to the respective sensor and distinguish also in the signal output or power supply.

8.4 Software update

The software version of VEGASON 61 can be determined as follows:

- on the type label of the electronics
- Via the display and adjustment module
- via PACTware

You can view all software histories on our website www.vega.com. Make use of this advantage and get registered for update information via e-mail.

The following components are required to update the sensor software:

- Sensor
- Voltage supply
- VEGACONNECT
- PC with PACTware
- Current sensor software as file

Load sensor software to PC

At "www.vega.com/downloads" go to "Software". Select under "*plics sensors and instruments*", "*Firmware updates*" the respective instrument series and software version. Load the zip file via the right mouse key with "*Save target as*" e.g. on the desktop of your PC. Move with the right mouse key to the folder and select "*Extract all*". Save the extracted files, for example on the desktop.

Prepare update

Connect the signal conditioning instrument to power supply and provide the connection from the PC to the instrument via the interface adapter. Start PACTware and go via the menu "*Project*" to the *VEGA project assistant*. Select "*USB*" and "*Set instruments online*". Activate the project assistant with "*Start*". The assistant establishes the connection automatically and opens the parameter adjustment window "*Sensor # online parameter adjustment*". Connect this parameter adjustment window before you carry out further steps.

Load software into sensor

Select with the right mouse key the sensor in the project and go to "*Additional function*". Then click to "*Software update*". The window "*Sensor # software update*" opens. PACTware checks now the sensor data and displays the actual hardware and software version of the sensor. This takes approximately 60 s.

Push the button "*Update software*" and select the previously extracted hex file. Then the software update can be started. The additional files are installed automatically. Depending on the sensor, this procedure lasts up to 1 h. Then the message appears "*Software update successfully executed*".

8.5 Instrument repair

If a repair is necessary, please proceed as follows:

You can download a return form (23 KB) from our Internet homepage www.vega.com under: "*Downloads - Forms and certificates - Repair form*".

By doing this you help us carry out the repair quickly and without having to call back for needed information.

- Print and fill out one form per instrument

- Clean the instrument and pack it damage-proof
- Attach the completed form and, if need be, also a safety data sheet outside on the packaging
- Please ask the agency serving you for the address of your return shipment. You can find the respective contact data on our website www.vega.com under: "*Company - VEGA worldwide*"

9 Dismounting

9.1 Dismounting steps

**Warning:**

Before dismantling, be aware of dangerous process conditions such as e.g. pressure in the vessel, high temperatures, corrosive or toxic products etc.

Take note of chapters "*Mounting*" and "*Connecting to power supply*" and carry out the listed steps in reverse order.

9.2 Disposal

The instrument consists of materials which can be recycled by specialised recycling companies. We use recyclable materials and have designed the parts to be easily separable.

WEEE directive 2002/96/EG

This instrument is not subject to the WEEE directive 2002/96/EG and the respective national laws. Pass the instrument directly on to a specialised recycling company and do not use the municipal collecting points. These may be used only for privately used products according to the WEEE directive.

Correct disposal avoids negative effects on humans and the environment and ensures recycling of useful raw materials.

Materials: see chapter "*Technical data*"

If you have no way to dispose of the old instrument properly, please contact us concerning return and disposal.

10 Supplement

10.1 Technical data

General data

Materials, wetted parts

- Process fitting, transducer PVDF
- Seal between transducer and process fitting EPDM, FKM (Viton)

Materials, non-wetted parts

- Housing Plastic PBT (polyester), Alu die-casting powder-coated, 316L
- Seal between housing and housing cover NBR (stainless steel housing), silicone (Alu/plastic housing)
- Inspection window in housing cover Polycarbonate
- Ground terminal 316Ti/316L

Weight 1.8 ... 4 kg (4 ... 8.8 lbs), depending on the process fitting and housing

Max. torque mounting boss 25 Nm

Output variable

Output signal 4 ... 20 mA/HART

HART output values

- HART value (Primary Value) Distance to the level
- HART value (Secondary Value) Temperature
- HART value (3rd Value) Distance to the level - scaled

Signal resolution 1.6 μ A

Failure signal current output (adjustable) mA-value unchanged 20.5 mA, 22 mA, < 3.6 mA

Current limitation 22 mA

Load see load diagram under Power supply

Damping (63 % of the input variable) 0 ... 999 s, adjustable

Met NAMUR recommendation NE 43

Input variable

Measured variable distance between lower edge of the transducer and product surface

Measuring range

- Liquids up to 5 m (16.4 ft)
- Bulk solids up to 2 m (6.562 ft)

Dead band 0.25 m (0.82 ft)

Reference conditions to measuring accuracy (according to DIN EN 60770-1)

Reference conditions according to DIN EN 61298-1

- Temperature +18 ... +30 °C (+64 ... +86 °F)
- Relative humidity 45 ... 75 %

- Air pressure	860 ... 1060 mbar/86 ... 106 kPa (12.5 ... 15.4 psig)
Other reference conditions	
- Reflector	ideal reflector, e.g. metal plate 2 x 2 m (6.56 x 6.56 ft)
- False reflections	Biggest false signal, 20 dB smaller than the useful signal

Measuring characteristics

Ultrasonic frequency	70 kHz
Interval	> 2 s (dependent on the parameter adjustment)
Abstrahlwinkel at -3 dB	11°
Step response or adjustment time ⁴⁾	> 3 s (dependent on the parameter adjustment)

Measuring accuracy

Resolution, general	> 1 mm (0.039 in)
Deviation ⁵⁾	see diagram

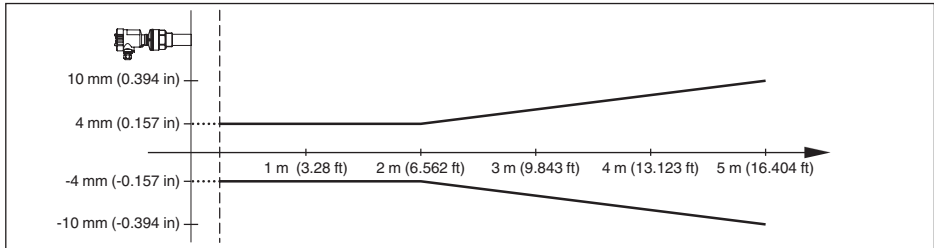

Fig. 29: Deviation VEGASON 61

Influence of the ambient temperature to the sensor electronics⁶⁾

Average temperature coefficient of the zero signal (temperature error) 0.06 %/10 K

Ambient conditions

Ambient, storage and transport temperature -40 ... +80 °C (-40 ... +176 °F)
 ture

Process conditions

Process pressure	-20 ... 200 kPa/-0.2 ... 2 bar (-2.9 ... 29 psig)
Process temperature (transducer temperature)	-40 ... +80 °C (-40 ... +176 °F)
Vibration resistance	mechanical vibrations with 4 g and 5 ... 100 Hz ⁷⁾

Electromechanical data - version IP 66/IP 67 and IP 66/IP 68; 0.2 bar

Cable entry/plug⁸⁾

⁴⁾ Time to output the correct level (with max. 10 % deviation) after a sudden level change.

⁵⁾ Incl. non-linearity, hysteresis and non-repeatability.

⁶⁾ Relating to the nominal measuring range.

⁷⁾ Tested according to the guidelines of German Lloyd, GL directive 2.

⁸⁾ Depending on the version M12 x 1, according to DIN 43650, Harting, 7/8" FF.

- Single chamber housing
 - 1 x cable gland M20 x 1.5 (cable: \varnothing 5 ... 9 mm), 1 x blind plug M20 x 1.5
 - or:
 - 1 x closing cap M20 x 1.5; 1 x blind plug M20 x 1.5
 - or:
 - 1 x closing cap ½ NPT, 1 x blind plug ½ NPT
 - or:
 - 1 \square x plug (depending on the version), 1 \square x blind stopper M20 \square x 1.5

- Double chamber housing
 - 1 x cable entry M20 x 1.5 (cable: \varnothing 5 ... 9 mm), 1 x blind plug M20 x 1.5; 1 x blind plug M16 x 1.5 or optionally available with 1 x plug M12 x 1 for external display and adjustment unit
 - or:
 - 1 x closing cap ½ NPT, 1 x blind plug ½ NPT, 1 x blind plug M16 x 1.5 or optionally 1 x plug M12 x 1 for external display and adjustment unit
 - or:
 - 1 x plug (depending on the version), 1 x blind plug M20 x 1.5; 1 x blind plug M16 x 1.5 or optionally available with 1 x plug M12 x 1 for external display and adjustment unit

Spring-loaded terminals for wire cross-section < 2.5 mm² (AWG 14)

Electromechanical data - version IP 66/IP 68 (1 bar)

Cable entry

- Single chamber housing 1 x IP 68 cable gland M20 x 1.5; 1 x blind plug M20 x 1.5
- Double chamber housing 1 \square x IP \square 68 cable gland M20 \square x 1.5; 1 \square x blind stopper M20 \square x 1.5; 1 \square x blind stopper M16 \square x 1.5

Connection cable

- Wire cross-section 0.5 mm² (AWG 20)
- Wire resistance < 0.036 Ω /m (0.011 Ω /ft)
- Tensile strength < 1200 N (270 lbf)
- Standard length 5 m (16.4 ft)
- Max. length 1000 m (3280 ft)
- Min. bending radius 25 mm (0.984 in) with 25 °C (77 °F)
- Diameter approx. 8 mm (0.315 in)
- Colour - standard PE Black
- Colour - standard PUR Blue
- Colour - Ex-version Blue

Display and adjustment module

- Voltage supply and data transmission through the sensor
- Indication LC display in dot matrix
- Adjustment elements 4 keys

Protection rating

- unassembled IP 20
- mounted into the sensor without cover IP 40

Material

- Housing ABS
- Inspection window Polyester foil

Voltage supply

Operating voltage

- Non-Ex instrument 14 ... 36 V DC
- Ex-ia instrument 14 ... 30 V DC

Operating voltage with illuminated display and adjustment module

- Non-Ex instrument 20 ... 36 V DC
- Ex-ia instrument 20 ... 30 V DC

Permissible residual ripple

- < 100 Hz $U_{ss} < 1\text{ V}$
- 100 Hz ... 10 kHz $U_{ss} < 10\text{ mV}$

Load see diagram

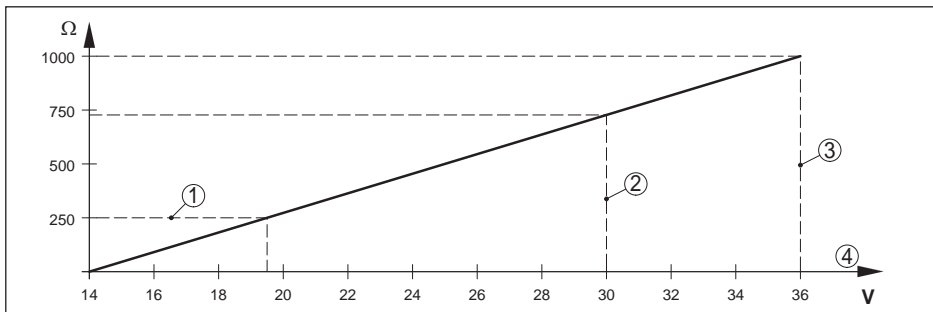

Fig. 30: Voltage diagram

- 1 HART load
- 2 Voltage limit Ex-ia instrument
- 3 Voltage limit non-Ex instrument
- 4 Operating voltage

Electrical protective measures

Protection, depending on housing version

- Plastic housing IP 66/IP 67
- Aluminium housing, stainless steel IP 66/IP 68 (0.2 bar)⁹⁾
housing - investment casting, stainless steel housing - electro-polished
- Aluminium and stainless housing, investment casting (optionally available) IP 66/IP 68 (1 bar)

⁹⁾ A suitable cable is the prerequisite for maintaining the protection rating.

Overvoltage category	III
Protection class	II

Functional safety (SIL)

Functional safety is already activated on instruments with SIL qualification ex factory. On instruments without SIL qualification ex factory, the functional safety must be activated by the user via the display and adjustment module or via PACTware for applications according to SIL.

Functional safety according to IEC 61508-4

- Single channel architecture (1oo1D) up to SIL2
- double channel diversitary redundant architecture (1oo2D) up to SIL3

You can find detailed information in the supplied Safety Manual of the instrument series or under "www.vega.com", "*Downloads*", "*Approvals*".

Approvals

Instruments with approvals can have different technical data depending on the version.

For that reason the associated approval documents of these instruments have to be carefully noted. They are part of the delivery or can be downloaded under www.vega.com via "*VEGA Tools*" and "*serial number search*" as well as via "*Downloads*" and "*Approvals*".

10.2 Dimensions

Housing in protection IP 66/IP 68 (0.2 bar)

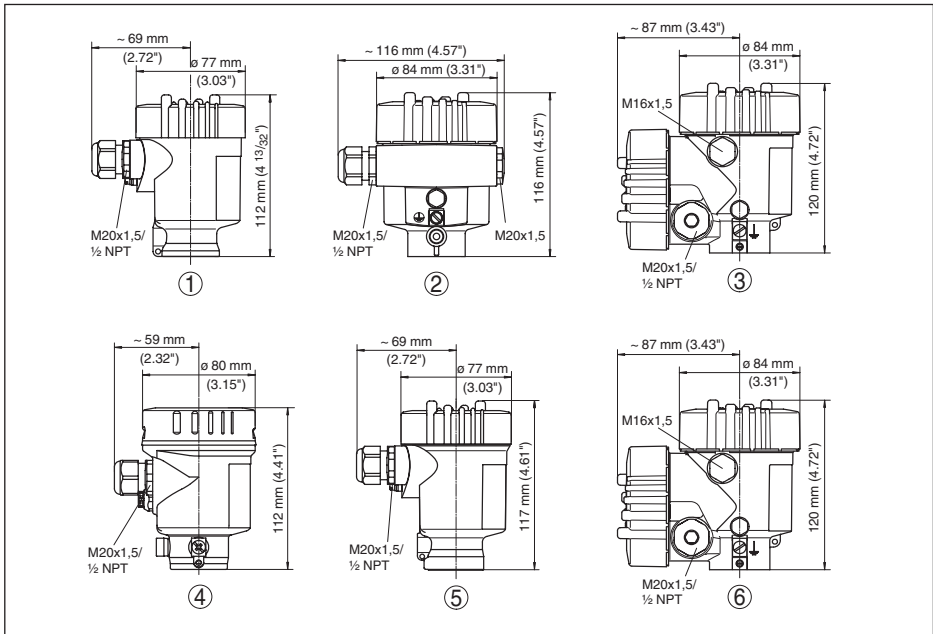

Fig. 31: Housing versions in protection IP 66/IP 68 (0.2 bar) - with integrated display and adjustment module the housing is 9 mm/0.35 in higher

- 1 Plastic housing
- 2 Aluminium housing
- 3 Aluminium double chamber housing
- 4 Stainless steel housing, electropolished
- 5 Stainless steel housing - precision casting
- 6 Stainless steel double chamber housing - precision casting

Housing in protection IP 66/IP 68 (1 bar)

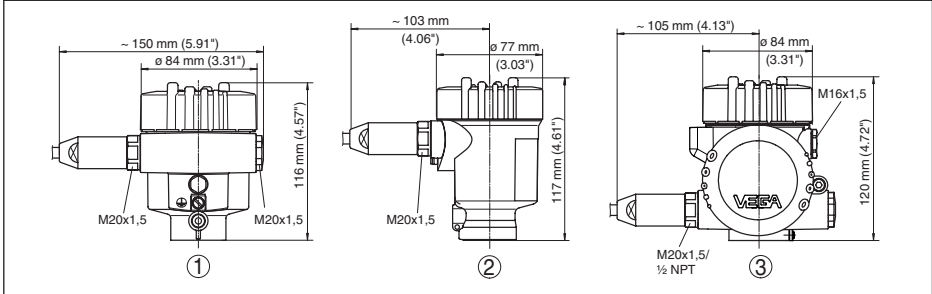

Fig. 32: Housing versions in protection IP 66/IP 68 (1 bar) - with integrated display and adjustment module the housing is 92 mm/0.35 in higher

- 1 Aluminium housing
- 2 Stainless steel housing - precision casting
- 2 Stainless steel double chamber housing - precision casting

VEGASON 61

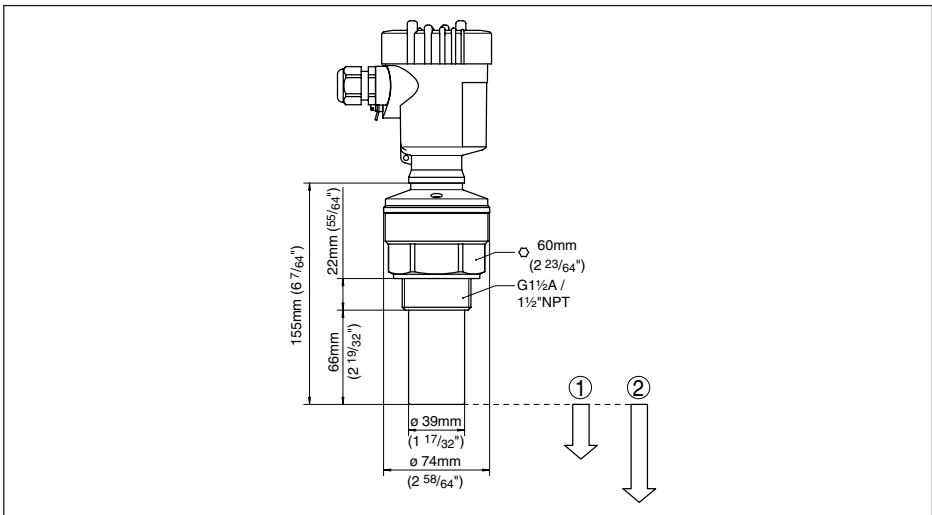

Fig. 33: VEGASON 61

- 1 Dead zone: 0.25 m (0.82 ft)
- 2 Measuring range: with liquids up to 5 m (16.4 ft), with solids up to 2 m (6.562 ft)

10.3 Industrial property rights

VEGA product lines are global protected by industrial property rights. Further information see www.vega.com.

Only in U.S.A.: Further information see patent label at the sensor housing.

VEGA Produktfamilien sind weltweit geschützt durch gewerbliche Schutzrechte.

Nähere Informationen unter www.vega.com.

Les lignes de produits VEGA sont globalement protégées par des droits de propriété intellectuelle. Pour plus d'informations, on pourra se référer au site www.vega.com.

VEGA líneas de productos están protegidas por los derechos en el campo de la propiedad industrial. Para mayor información revise la pagina web www.vega.com.

Линии продукции фирмы ВЕГА защищаются по всему миру правами на интеллектуальную собственность. Дальнейшую информацию смотрите на сайте www.vega.com.

VEGA系列产品在全球享有知识产权保护。

进一步信息请参见网站<www.vega.com>。

10.4 Trademark

All the brands as well as trade and company names used are property of their lawful proprietor/originator.





Printing date:

VEGA

All statements concerning scope of delivery, application, practical use and operating conditions of the sensors and processing systems correspond to the information available at the time of printing.

Subject to change without prior notice

© VEGA Grieshaber KG, Schiltach/Germany 2013



28775-EN-130417

VEGA Grieshaber KG
Am Hohenstein 113
77761 Schiltach
Germany

Phone +49 7836 50-0
Fax +49 7836 50-201
E-mail: info.de@vega.com
www.vega.com